

Working With Business Processes Masterclass— *Aligning Process Work with Strategic, Organisational, and Cultural Factors*

Presented for ING Bank by
Adept Events and Clariteq Systems Consulting

Alec Sharp
Consultant
Clariteq Systems Consulting Ltd.
West Vancouver, BC, Canada
asharp@clariteq.com
www.clariteq.com

Developer/instructor background...



Alec Sharp, Clariteq Systems Consulting – asharp@clariteq.com

- 40+ years experience as an independent consultant:
 - *Business Process Change* – discover, model, analyse, and design/redesign processes
 - Concept Modelling (Business-friendly Data Modelling)
 - Application Requirements Specification
+
 - Facilitation & Organisational Change
 - Project Recovery

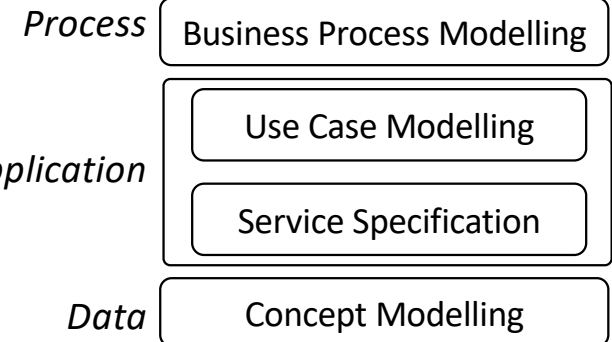

- Consulting, teaching, speaking globally
- Awarded DAMA's global Professional Achievement Award for contributions to "human-friendly" data modelling
- Author of "Workflow Modeling"
 - best-selling book on process modelling & improvement
 - second edition – 2009 (sole author, complete re-write)

Check out the nice reviews
on Amazon - <http://amzn.to/dHun1o>

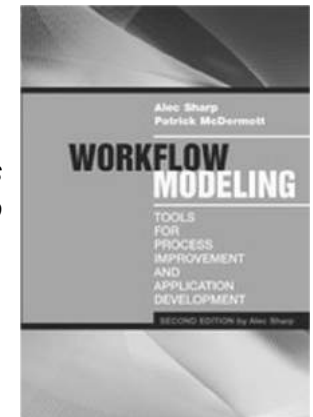

Background for this course

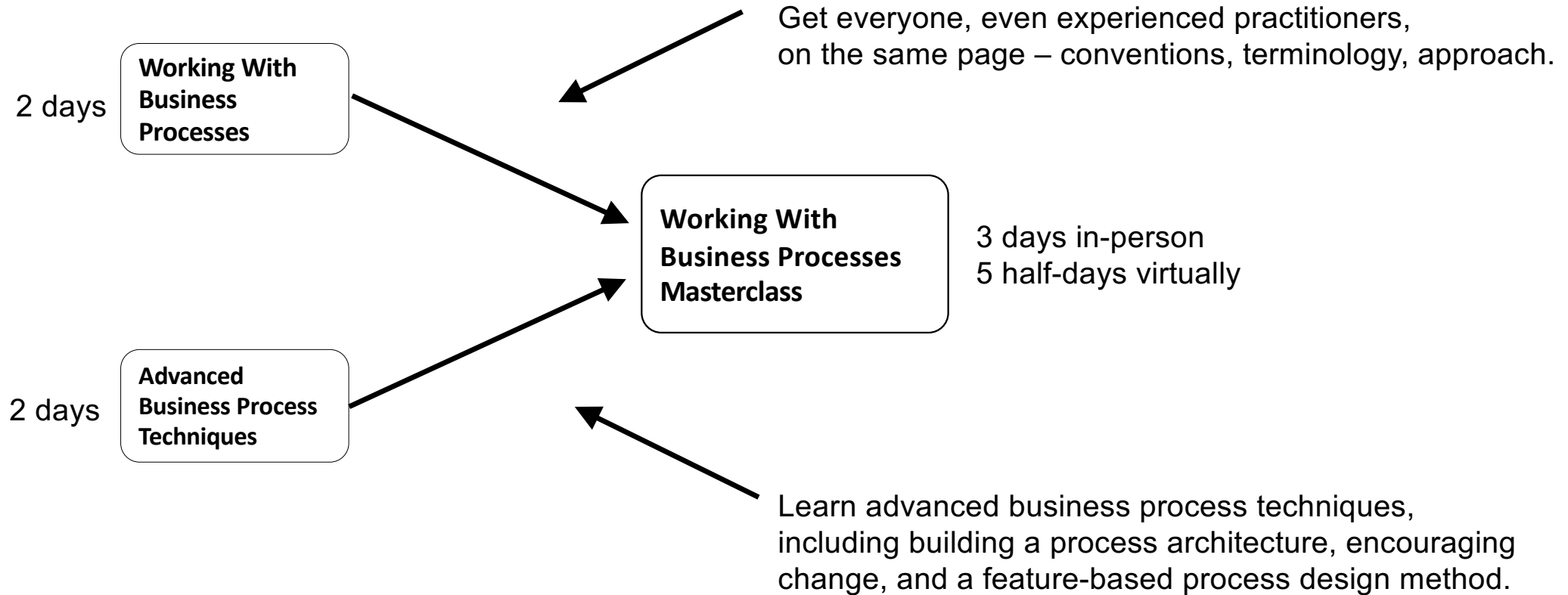

Notes:

- Advanced courses don't follow a step-by-step methodology – more “tips and techniques.” That said, the flow of the course mirrors a typical Business Process Change initiative.
- Some exercises, but we'll rely mainly on discussion and sharing of experience/examples

Themes and overview...

Three main themes:

1. *Simple* techniques, *rigorously* applied, help us achieve *more* in *less time*.
2. *Communication with* and *engagement of* the people who *do the work*.
3. A *holistic* not *technocratic* approach, including *human, social, & organisational* factors.

And finally... **YOU:**

- Name – how should I address you?
- Role / job title and organisation
- Brief description of your work
- A topic you are especially interested in?
- *Please keep your intro under 1 minute*

Section 1 – Fundamentals

- Five things you need to communicate about *business processes*
- How *Business Process* fits into a framework for *Business Analysis*
- A three-phase methodology for *Business Process Change*

Sections 2 to 6 – Techniques

2. Identifying true, end-to-end, cross-functional *Business Processes*
3. Developing a *Process Architecture* (including an interlude on *Concept Modelling*)
4. Seven ways to help people embrace *Process Change*
5. *Human-oriented* process modelling
6. A feature-based *Process Design* method – transitioning from *as-is* to *to-be*

Business Processes – what people need to know

1. Communicating the fundamentals of *Business Processes*
2. Identifying true, end-to-end, cross-functional *Business Processes*
3. Developing a *Process Architecture*
4. Seven ways to help people embrace *Process Change*
5. *Human-oriented* process modelling
6. A feature-based *Process Design* method –
transitioning from *as-is* to *to-be*

An executive briefing on Business Processes

Assume you are doing a briefing for the executives at an organisation on the importance of proactively managing *Business Processes*. What points will you make?

Key point #1.

Never assume everyone agrees what a *Business Process* is...

... there are a wide range of opinions!

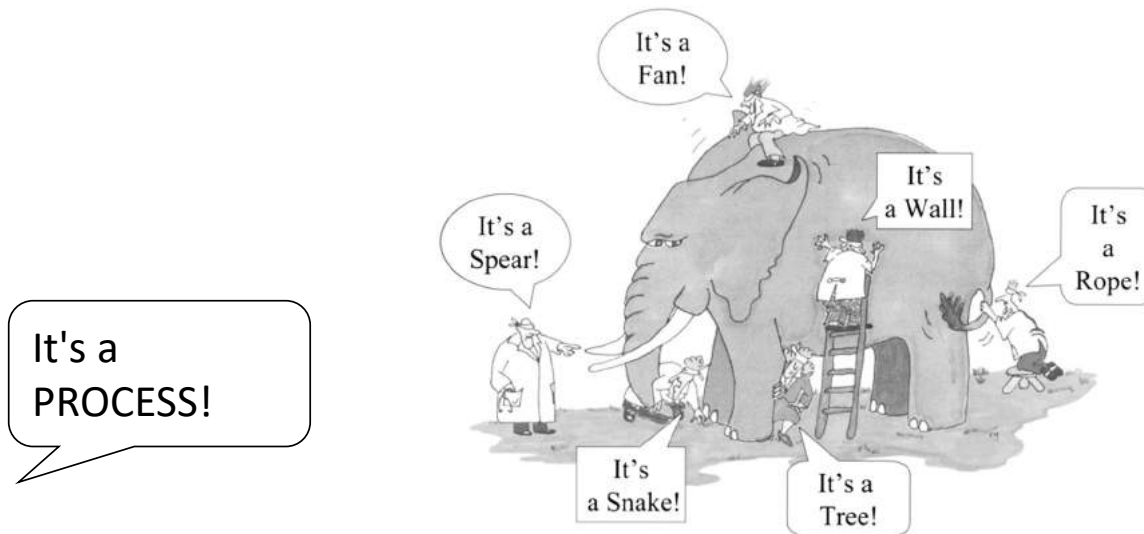

Key point #2 for the executive briefing

*Don't preach or oversell –
making the case for BPM may not work as planned*

Benefits of BPM – the usual suspects

1. Reduce costs and increase efficiency
(The perennial #1)
2. Improve customer service
3. Increased responsiveness / innovation
4. Regulatory compliance

BUT... why not promote BPM with these claims?

*Every other discipline makes the same claims
so nobody believes you anyway.*

Five central ideas

1. It's essential to have clarity on what a *business process* really is
2. Existing performance measures are often *functionally aligned* and work *against* business processes
3. Enterprise system implementations *must* include a *business process* perspective
4. Success with business processes depends on taking a *holistic view* in which six *enablers* are considered
5. Business processes can't be great at everything – a single *differentiator* or *strategic discipline* should be chosen

1. Confusion – what is a “business process?”

1. It is essential to have clarity on what a *business process* really is
2. Performance measures may be *functionally aligned* - work *against* business processes
3. Enterprise system implementations must include a business process perspective
4. Success with business processes requires a *holistic view* in which *six enablers* are considered
5. A business process can't be great at everything – a single *differentiator* must be chosen

In the early 1990s, Michael Hammer popularised the focus on *business process*

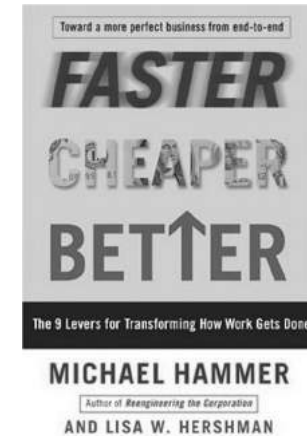
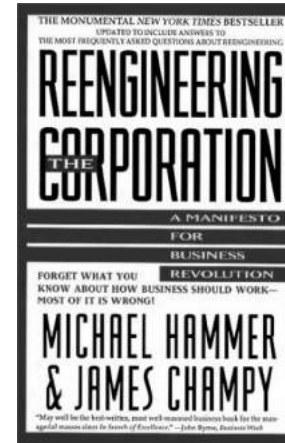
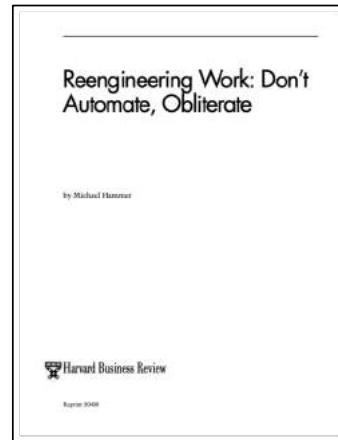

Introduced core terminology:

- end-to-end, cross-functional, functional silo, ...
- even *business process*

Still, people and organisations miss the point...

Lesson #1 – Never assume everyone agrees what a "process" is

We need some help with our *Product Lifecycle Management* process.

Not a single process –
it's a *family* of multiple
business processes
(a *process area* or
process domain)



I spend all day writing business
processes, like the process to
Revise Product Brochure Image.

Not an entire process –
it's a *procedure* providing
instructions for a single task
(SWI – standard work
instructions)

A whole *spectrum* of interpretations of *process*.

Seek balance –
a "business process"
lies between the extremes

Most people hear *process*
and think *procedure*!

The key issues – granularity and orientation

A collection of processes vs. a process vs. a procedure

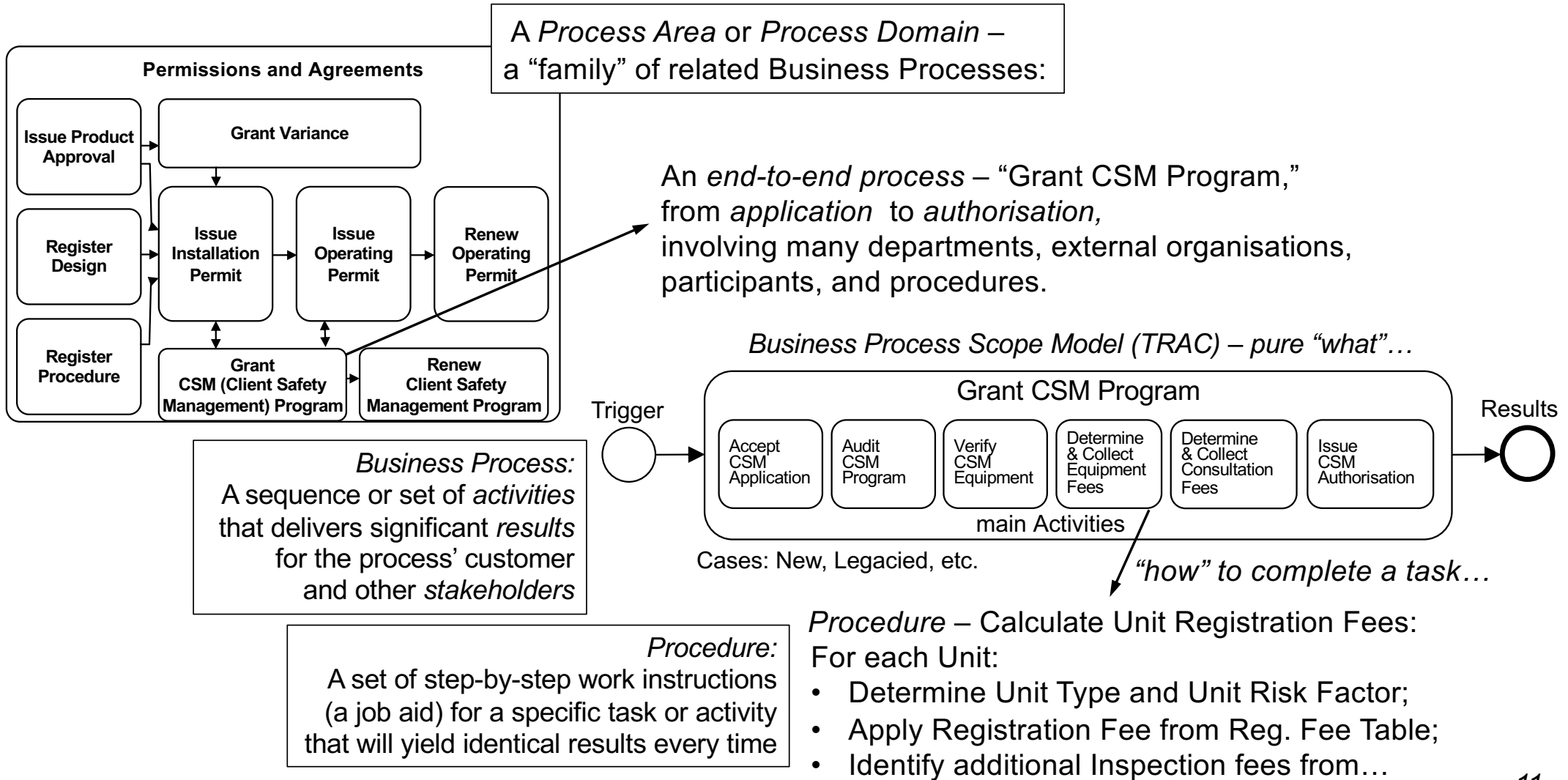

For reference – Process vs. Procedure

Process:

(or “end to end, cross-functional, Business Process”)

A sequence or set of *activities* that delivers significant *results* for the process’ customer and other *stakeholders*

- involves multiple participants (actors or roles) and multiple organisation units / functions
- may or may not have a defined workflow
- initially break a *process* into five to seven *major activities* (*subprocesses, phases, or milestones*)
each made up of more granular *activities* or *tasks*
each of which might contain one or more documented *procedures*

*Business Process –
a concept that is better demonstrated than defined.*

Procedure:

A set of work instructions – a *job aid* – for a specific task or activity that will yield identical results every time.

- Usually one person or a small number of persons;
- Usually within a single function or organisational unit;
- a.k.a. Standard Work Instructions (SWI) or Standard Operating Procedure (SOP)

A real life (and expensive!) example

As part of a massive system implementation, a global manufacturer identified the *business processes* that were expected to improve:

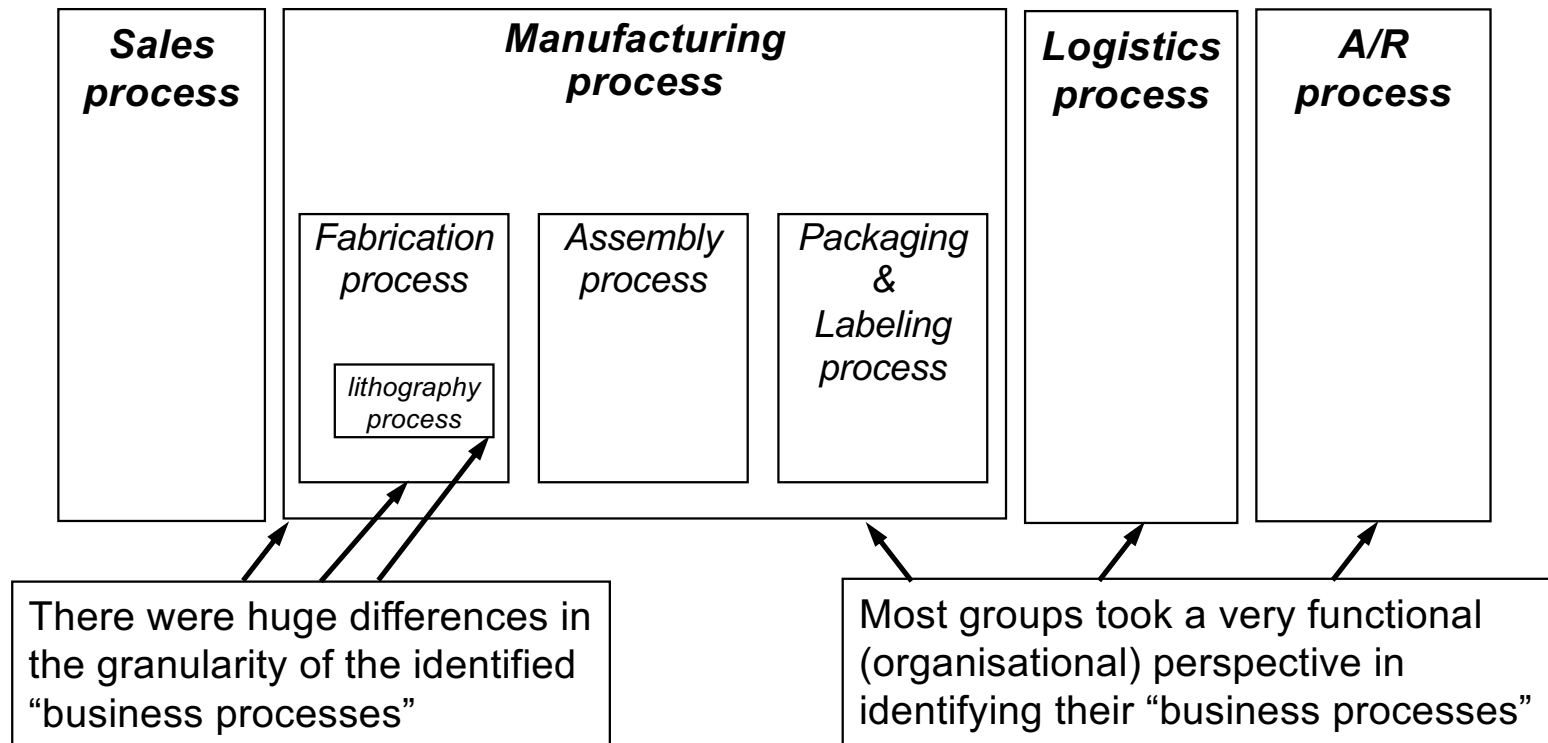

The problem? *These aren't processes – they're functions!*

The “real” business processes were missed

Everyone confused “process” and “function.”
None of the actual end-to-end processes
were correctly identified.

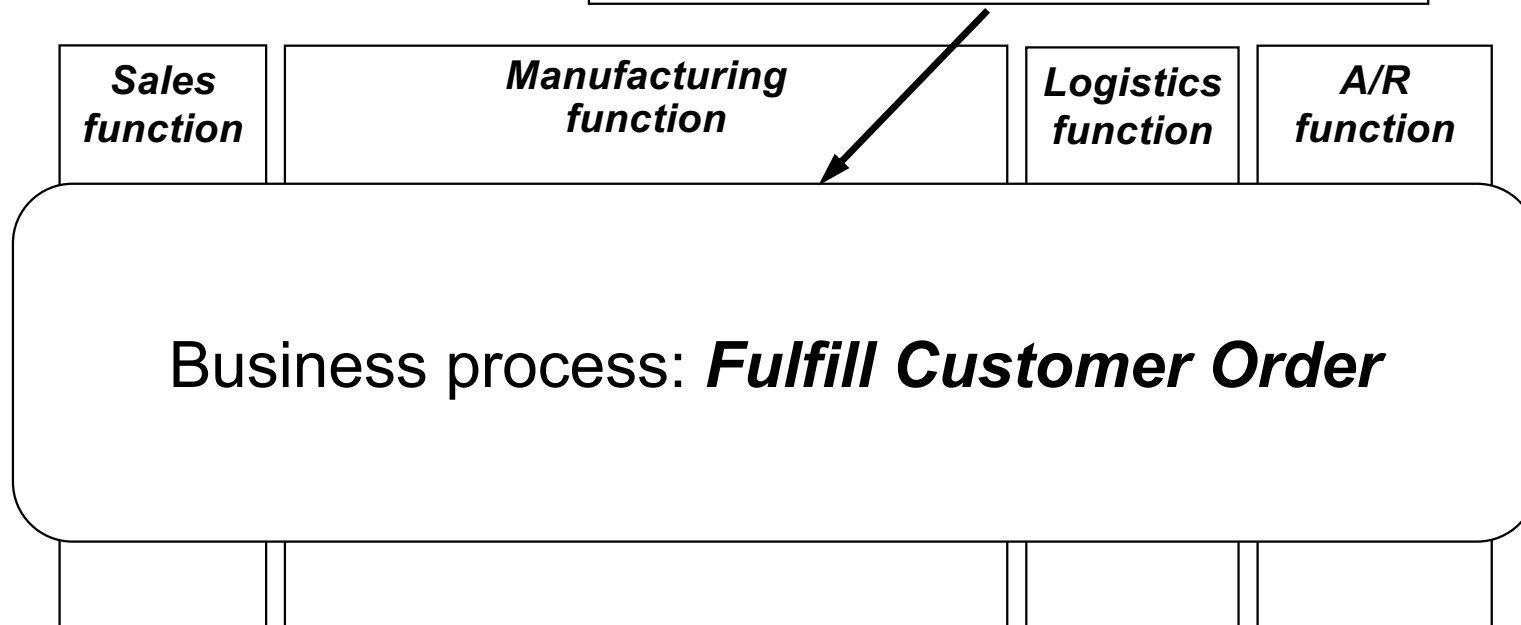

“Business Process” =
end-to-end, cross-functional, business process.

“Larger” than people think – from *initial* trigger to *final* results.

Discuss - what are the boundaries of the process?

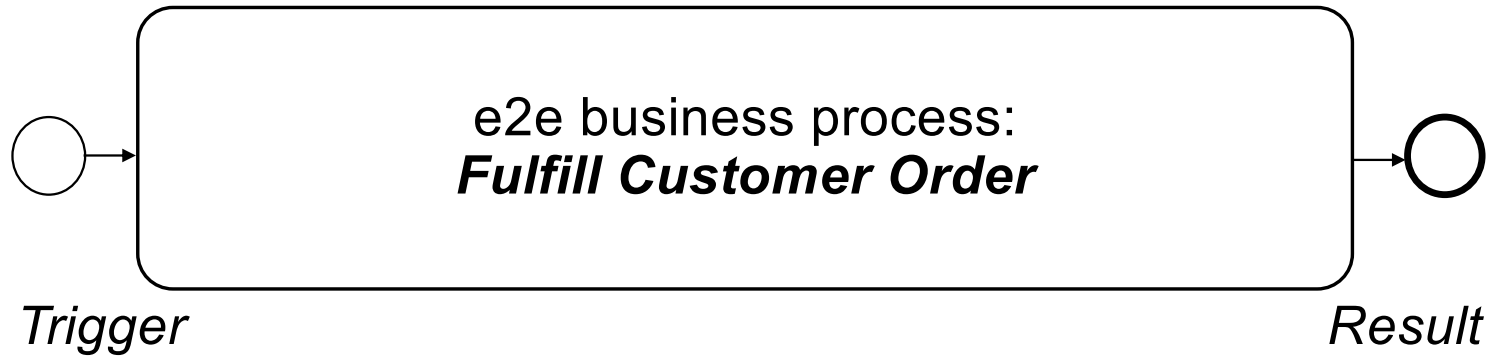

What are the boundaries of the process?

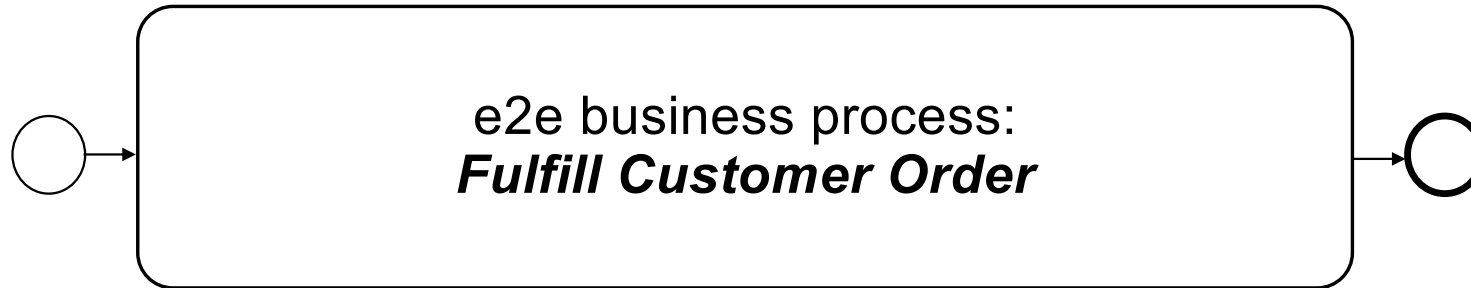

Trigger

Order received? *No.*

Before that...

- Contract is Finalised
- Price & Schedule are Negotiated
- Specifications are Confirmed

And before that...

- Demand is Signalled. *Yes.*

Result

Order is Shipped? *No.*

Order is Received? *No.*

Order is Received, Tested,
and Accepted? *Yes.*

Any other results?

Yes, for other stakeholders.

*Always trace to the earliest trigger,
and to the final results for each stakeholder.*

Process Scope Model – “what” first, “who and how” later

I build a
Process Scope Model & a
Process Summary Chart on
~100% of Project Recovery
assignments -

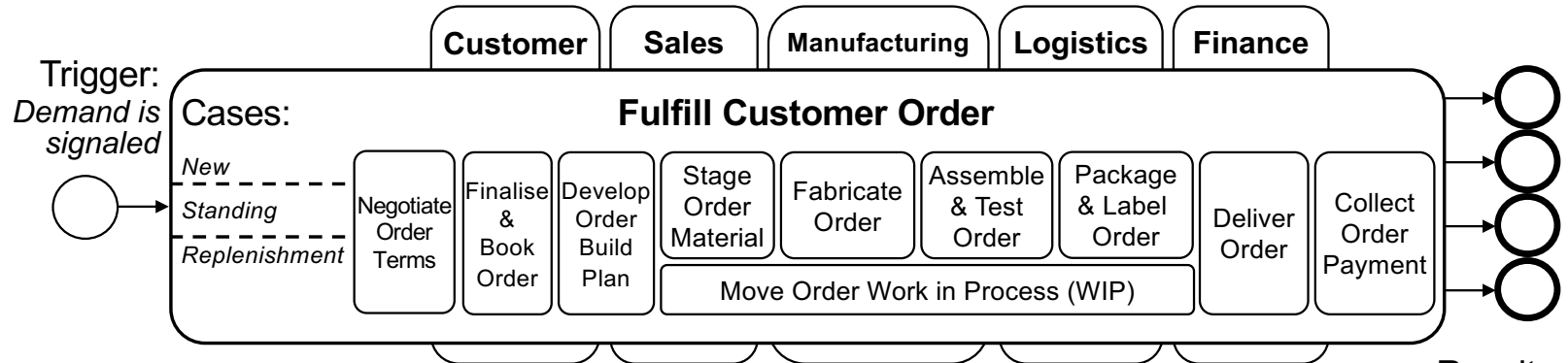

“TRAC” –

1 – **Triggering event or events**

2 – **Results: final outputs**

- result(s) received by the process' primary customer
- result(s) for other stakeholders (performers, owner, supplier, regulator, ...)

3 – **Activities: 7 +/- 2 phases, milestones, or sub-processes**

- a phase achieves a significant intermediate result
- simply ask the participants for ~5 to 7 milestones within the process

4 – **Cases**

- main variations, e.g. “new order” vs. “standing order”
- verb – *qualifier* – noun

5 – **Functions or Organisation Units**

6 – **Actors and responsibilities**

7 – **Systems, data sources, other mechanisms**

↑ **essence of the process (“what”)**

↓ **as-is elements of the process, for clarification (“who and how”) (6 and 7 not shown)**

Results:

Customer:

Goods received, tested, & accepted

Owner:

Payment received

Performer:

Commission credited

Industry Association:

Order stats reported

Always construct a
Process Scope Model & a
Process Summary Chart before
diving into Workflow Modelling /
Swimlane Diagramming

The essential framework

Business Process:

- a sequence (or set) of *activities* (steps and decisions,)
- initiated in response to a *triggering event*,
- that achieves a defined *result* for each process stakeholder

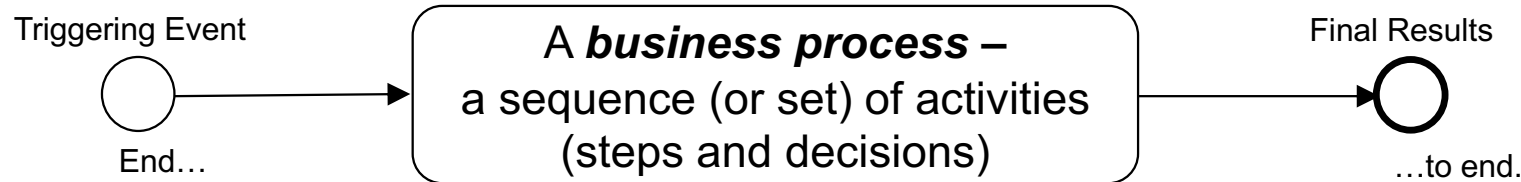
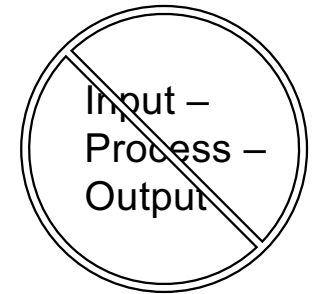

- Three types of events:
 - Decision-based (action)
 - Time-based (temporal)
 - Data-based (conditional)
- The *earliest* triggering event

- Important processes are virtually always cross-functional and involve multiple actors / roles
- May be a defined *sequence*, or a more ad hoc *set* of activities
- First, identify “*what*” it includes – Trigger, Results, Activities, Cases (“TRAC”)
- Later, we add “*who and how*,” then map the process flow, if there is one

- Three types of results:
 - A service
 - A good
 - Information
- The *final* result

“What” before diving into the “who and how”

Another Business Process example, if we have time

A regional telecommunications provider (the "Telco") thought they had three main Business Processes, and efforts to improve them were failing:



The outcome...
conflict between functional areas!

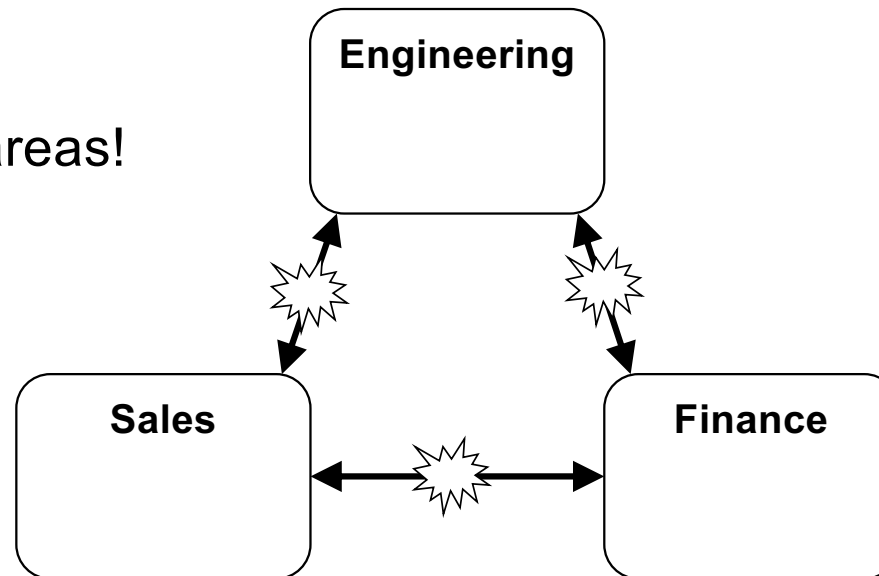

Process Scope Model showed ONE process not THREE

TRAC

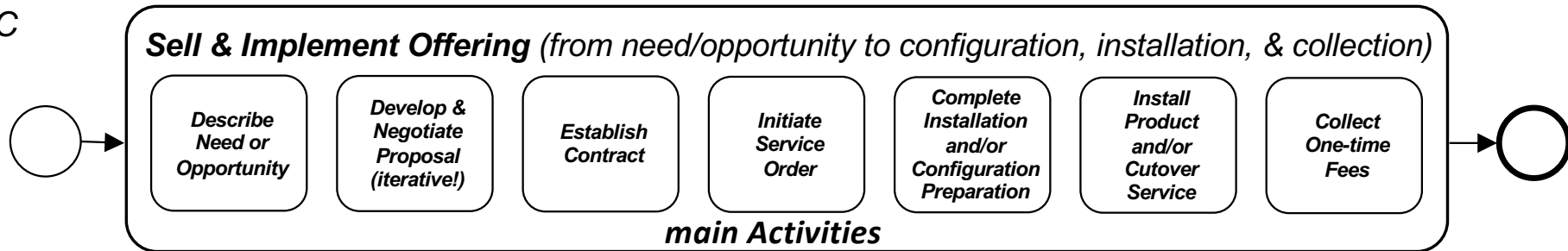

Triggering Event:

- Prospect / Customer expresses need
- Telco (Inside Sales, Marketing, Sales Rep, ...) recognizes opportunity

Cases:

- BU with or without Telco Internet, no cabling (*our focus*)
- initial installation
- service only
- product only
- mixed

Other factors:

- TBD

Results:

Customer:
Product / Service is *installed and operational* per original or amended contract terms

Telco:

- Ongoing source of *revenue* in place
- One-time fees collected

Employee:

- *Commission* or *referral credit*

Agent:

- *Commission*

The "token," a Service Order, is changing state from *need/opportunity* to *configured, installed, & collected*.

The Business Process could be named "Fulfill Service Order" but the client wanted to name it "Sell & Implement Offering."

"We're all in this together!"
An end-to-end, cross-functional Business Process is a great lens to view organisation conflict and disfunction!

Process Summary Chart – my favourite diagram!

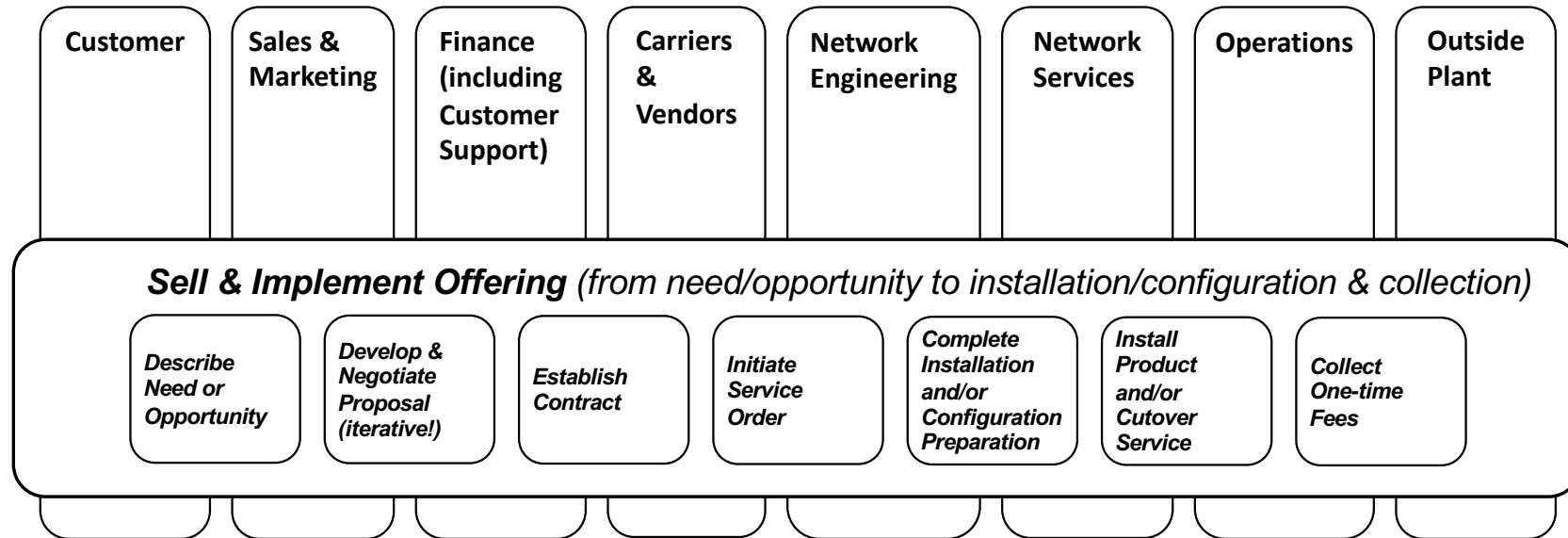

Process Summary Chart (a.k.a. "Process vs. Function Chart") adds "who" at the organisational unit or functional level.

Nothing else clarifies "Process" vs. "Function/Organisation" as well.

Great for putting details of Activities or Functions in context, e.g. ...

Multiple roles by organisation for “Sell & Implement Offering”

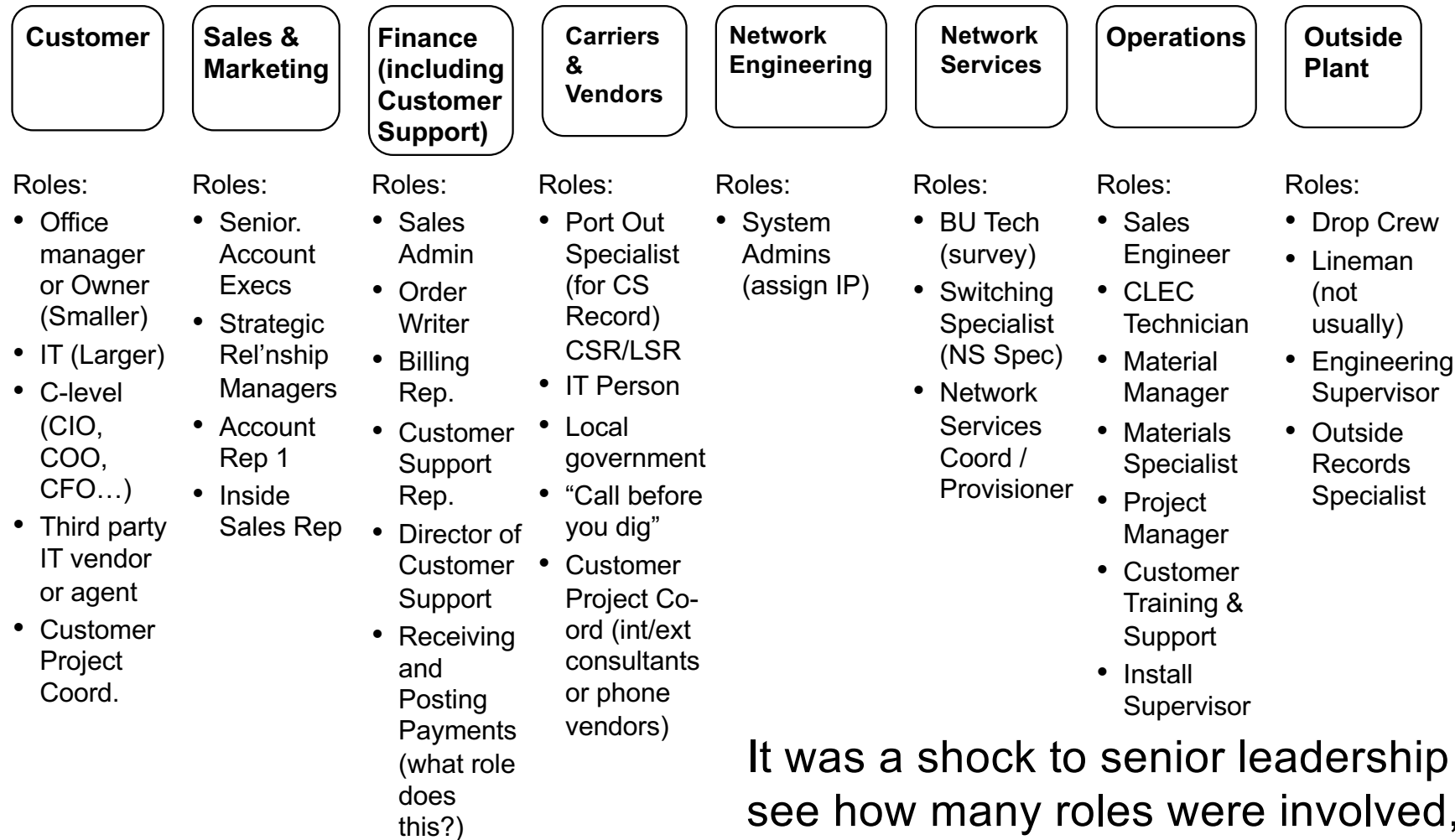

It was a shock to senior leadership to see how many roles were involved, often overlapping or unnecessarily

Many benefits to starting with a Process Scope Model

Why start with a *Process Scope Model*?

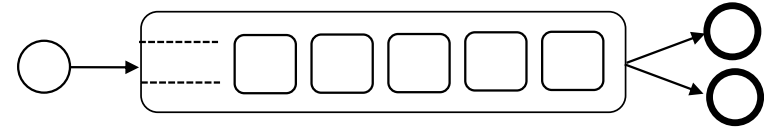

Then a *Process Summary Chart*?

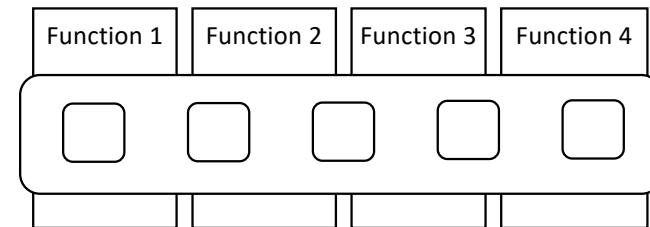

- People see themselves as part of something larger and more important than their own job, department, systems, ...
- Without this, issues and objectives will be seen in functional (organisational) terms
- Actual client comments – "The focus on *what*...
 - adds clarity and critical thinking."
 - highlights how far removed "as-is" is from "what" they're trying to do."
 - avoids the tension that comes with "who and how," which is personal."

Naming conventions will make life easier

1. The process name **must** indicate the expected result

- Name potential process in “verb – noun” format
- Restate that name as a result (“noun is verbed”)
- Ensure this is the intended result of the process: *discrete*, so results are *identifiable & countable*
- **No mushy verbs:** manage, monitor, administer, handle, track, support, maintain, etc.
- **Active verbs only:** *Evaluate Prospect, Onboard Customer, Fill Customer Order, Resolve Customer Issue, ...*
- Applies to business processes, phases (subprocesses,) activities, steps, ...

2. Name process from customer's perspective (what do they want from the process?)

3. Name process in the singular

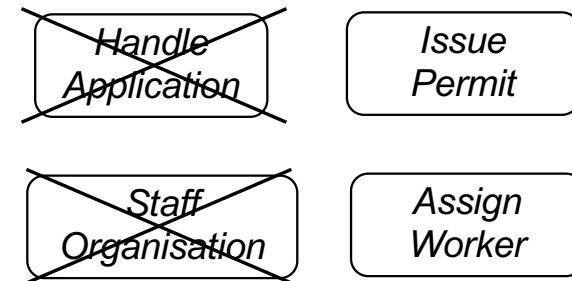
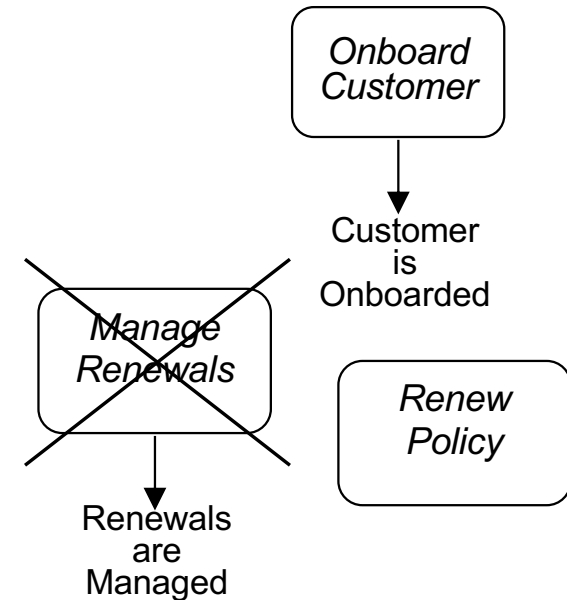

An example from higher education

As part of a strategic initiative to address falling graduation rates, a university took a process-based approach to determine why they were failing to admit the most promising candidates...

The “processes” that were initially identified...

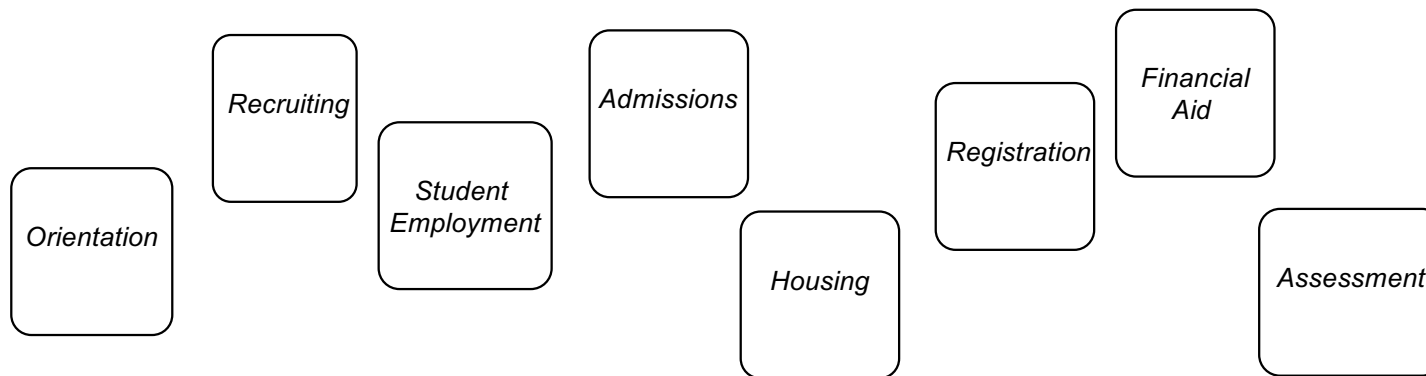

Are these good business processes?

NO! Each of these is a department or function.

We convened a facilitated session to determine the "real" process

Rename, reduce, refine, and sequence

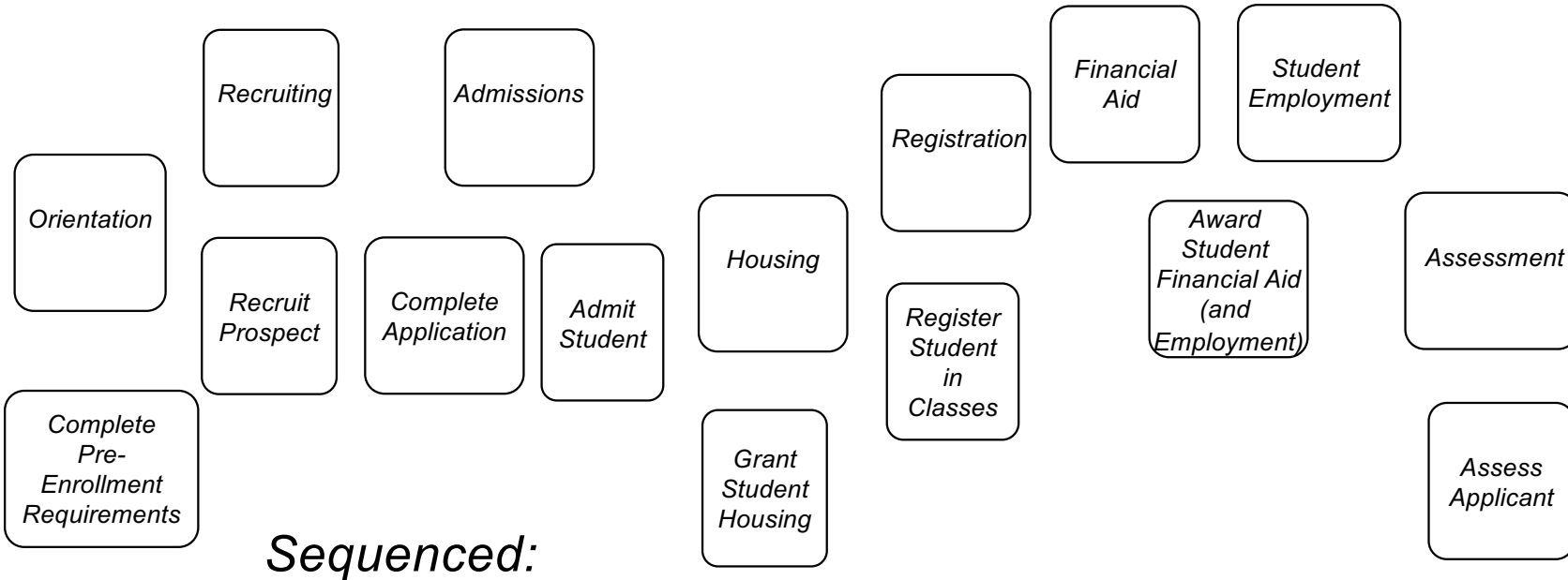

Sequenced:

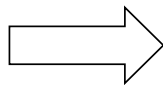
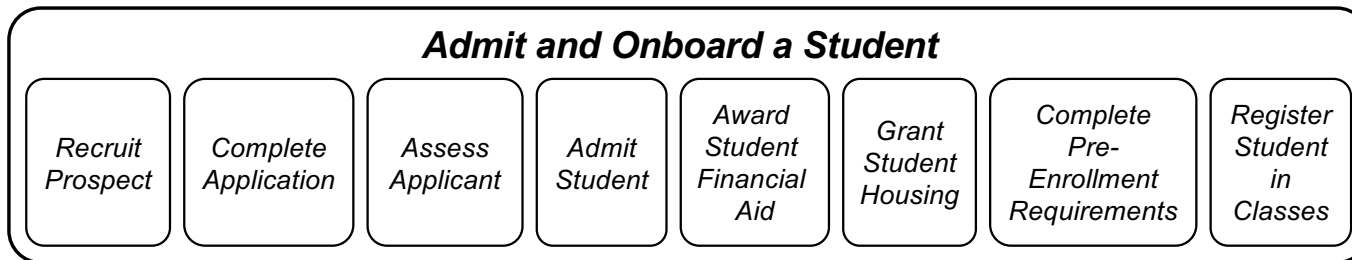

Token: A student,
from prospect to registered

From the session – “Is it a single X-functional process?”

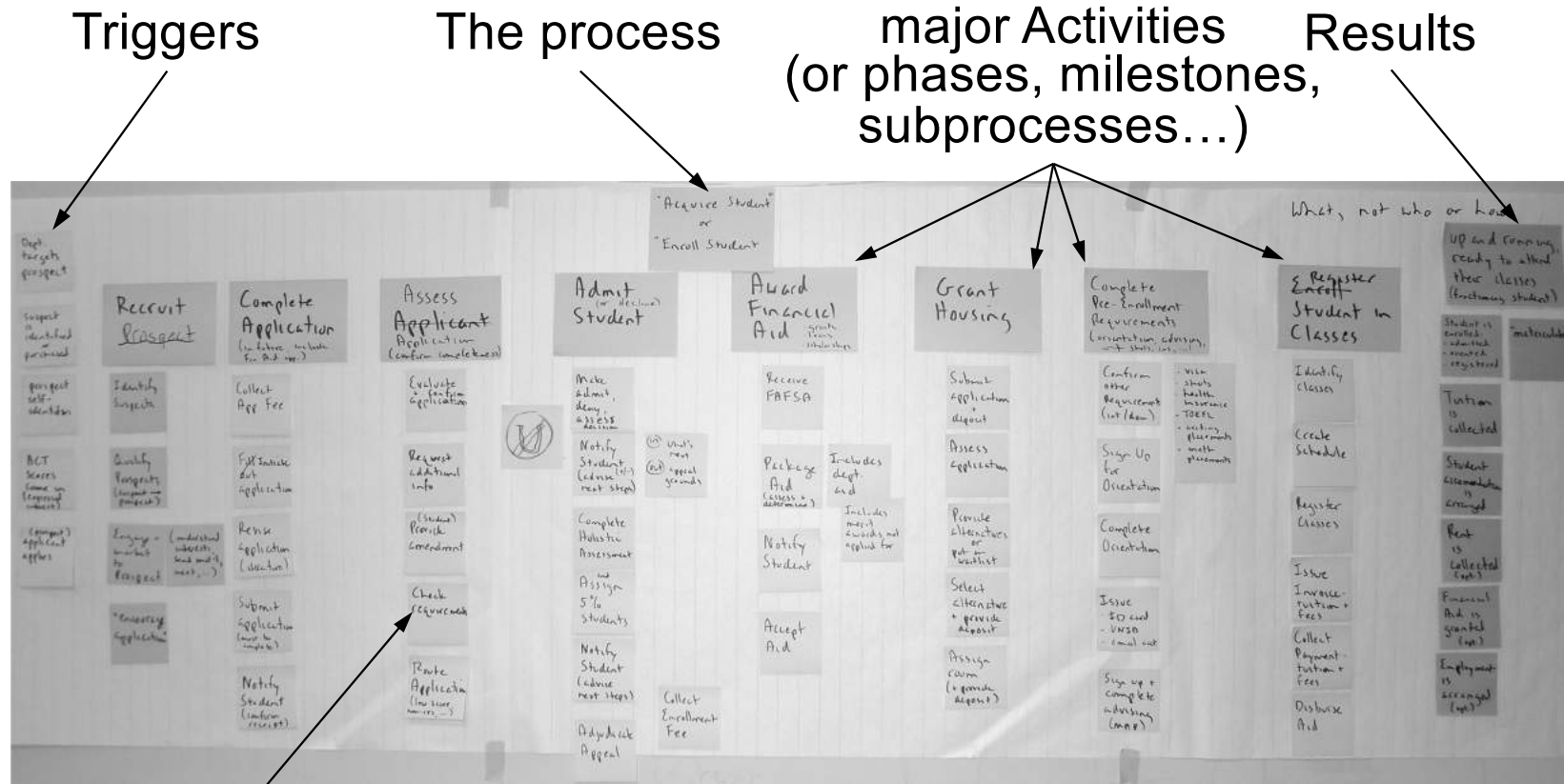

More detailed activities

Focus is on “what, not who or how.”
Note the high-tech tools.

Very iterative, but only 90 minutes!

The cleaned-up “Process Scope Model”

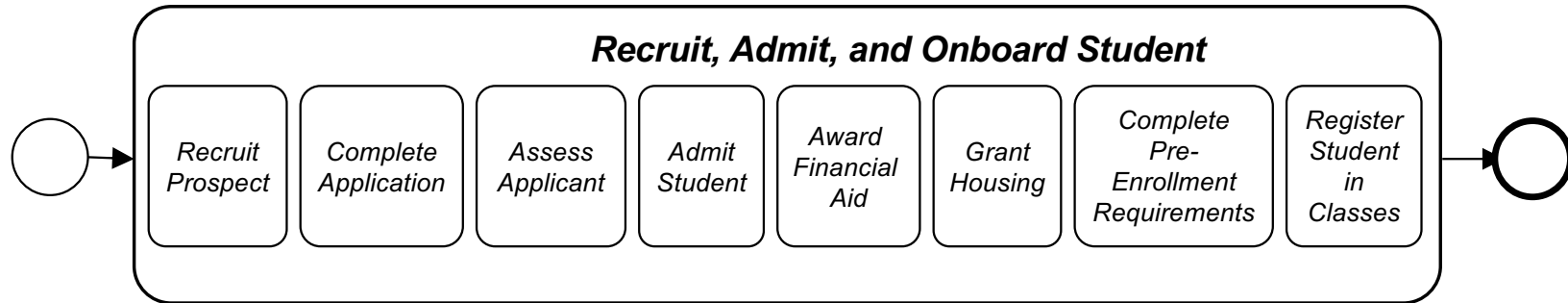

Triggering Events:

- Dept. targets prospect
- Suspect is identified or purchased
- Prospect self-identifies
- ACT scores come in
- Prospect applies
- ...

Cases:

- In-state undergrad
- Out-of-state undergrad
- ...

Final Results:

“Up and running,”
ready to attend classes:

- Student is:
 - admitted
 - oriented
 - registered
- Tuition is collected
- Student accommodation is arranged
- Financial aid is granted
- Employment is arranged
- ...

TRAC –

- Trigger
- Results
- Activities (~5-7 phases or milestones)
- Cases (major Variants)

The cleaned-up “Augmented Scope Model”

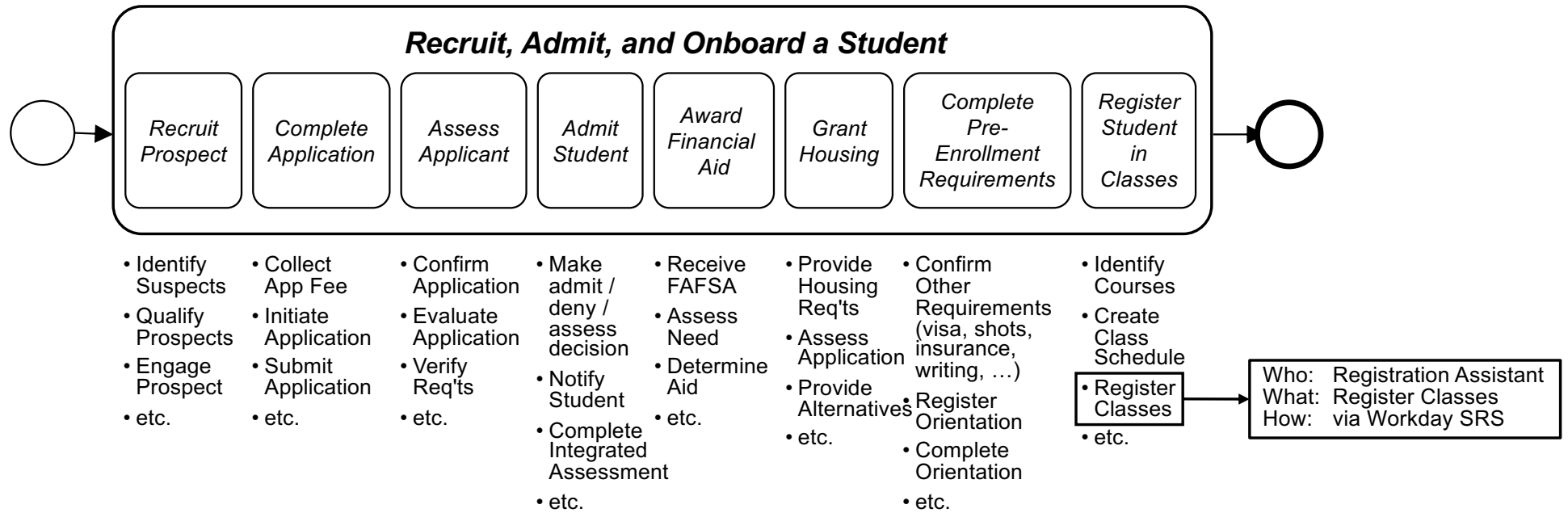

*Typically, 5 – 7 activities identified within each major activity.
Initially just “what” (verb – noun) – later, add “who and how,”
e.g., Registration Assistant (who) Register Classes (what) via Workday SRS (how)*

Identifying the functional area responsible for each activity revealed the process was massively cross-functional...

Process Summary Chart shows an astonishingly cross-functional process

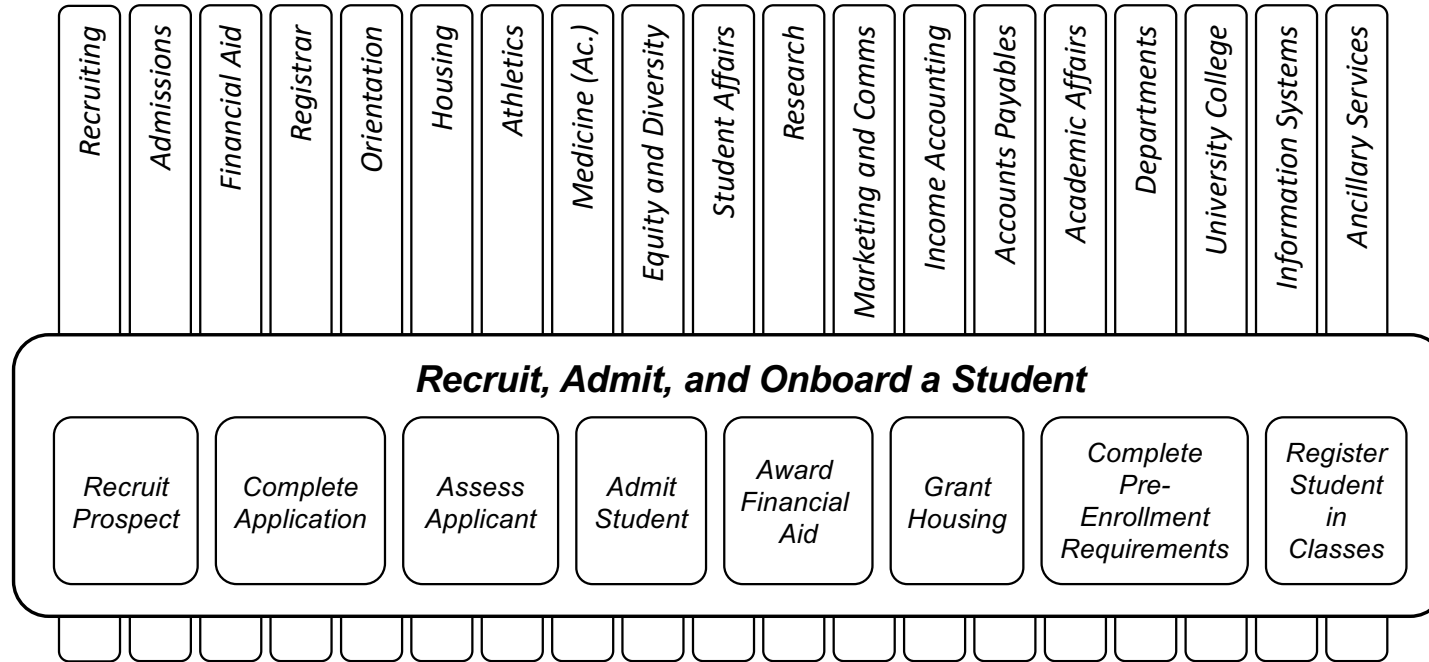

Without explicitly addressing the end-to-end process:

- almost no chance the student experience is positive
- very frustrating for the people doing the work
- almost no chance the university is going to meet its goals

Two key points:

1. Functions are doing their best to optimise their activities
2. A multitude of dis-integrated systems and data sources are being used

The point – the execs
said "Get on with it!" No
need to burn up \$50,000
on a business case."

2. A common obstacle – misaligned performance measures

A Process
Summary
Chart

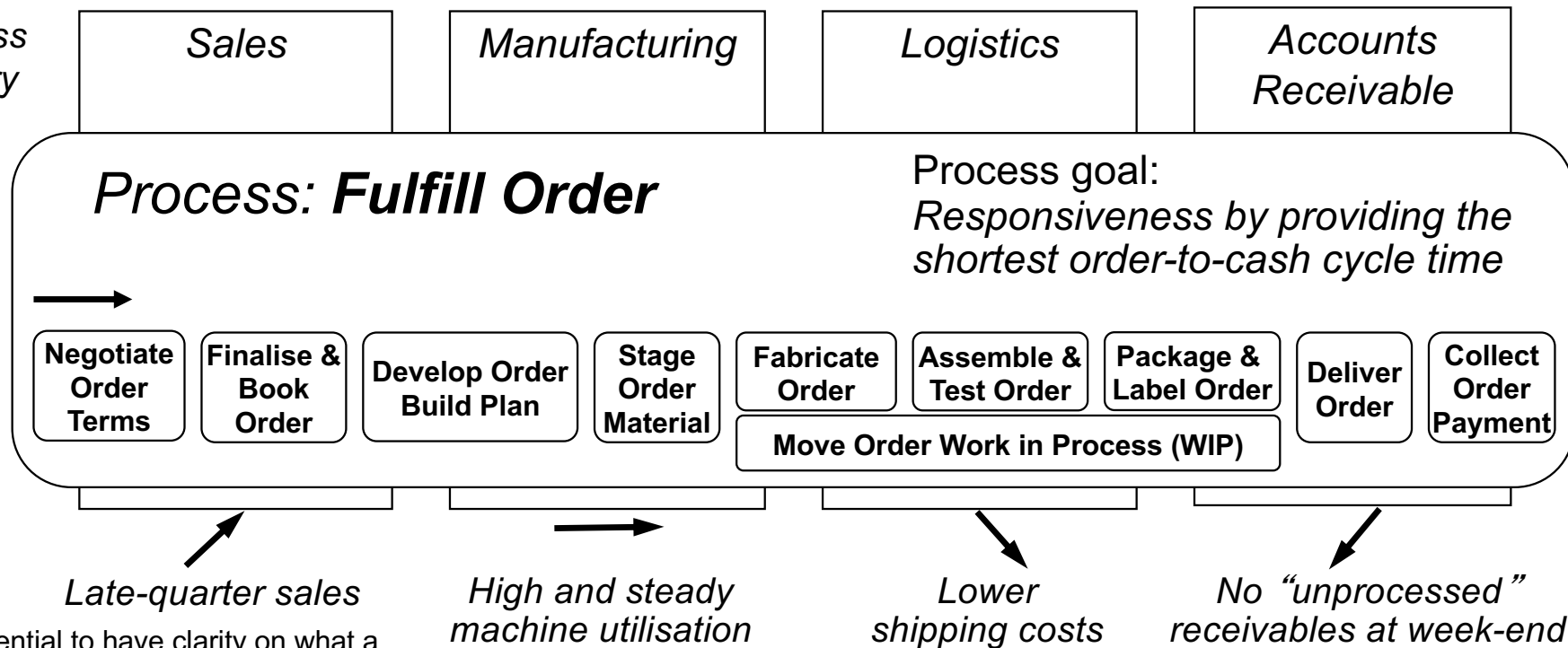

1. It is essential to have clarity on what a business process really is

2. Performance measures may be *functionally aligned* and work *against* business processes

3. Enterprise system implementations must include a business process perspective

4. Success with business processes requires a *holistic view* in which six *enablers* are considered

5. A business process can't be great at everything – a single *differentiator* must be chosen

But... performance measures were established *functionally*, before awareness of the *end-to-end process*

Discuss –

*What are the likely impacts of these performance goals?
What will the different functions do to meet the targets?*

Misaligned performance measures

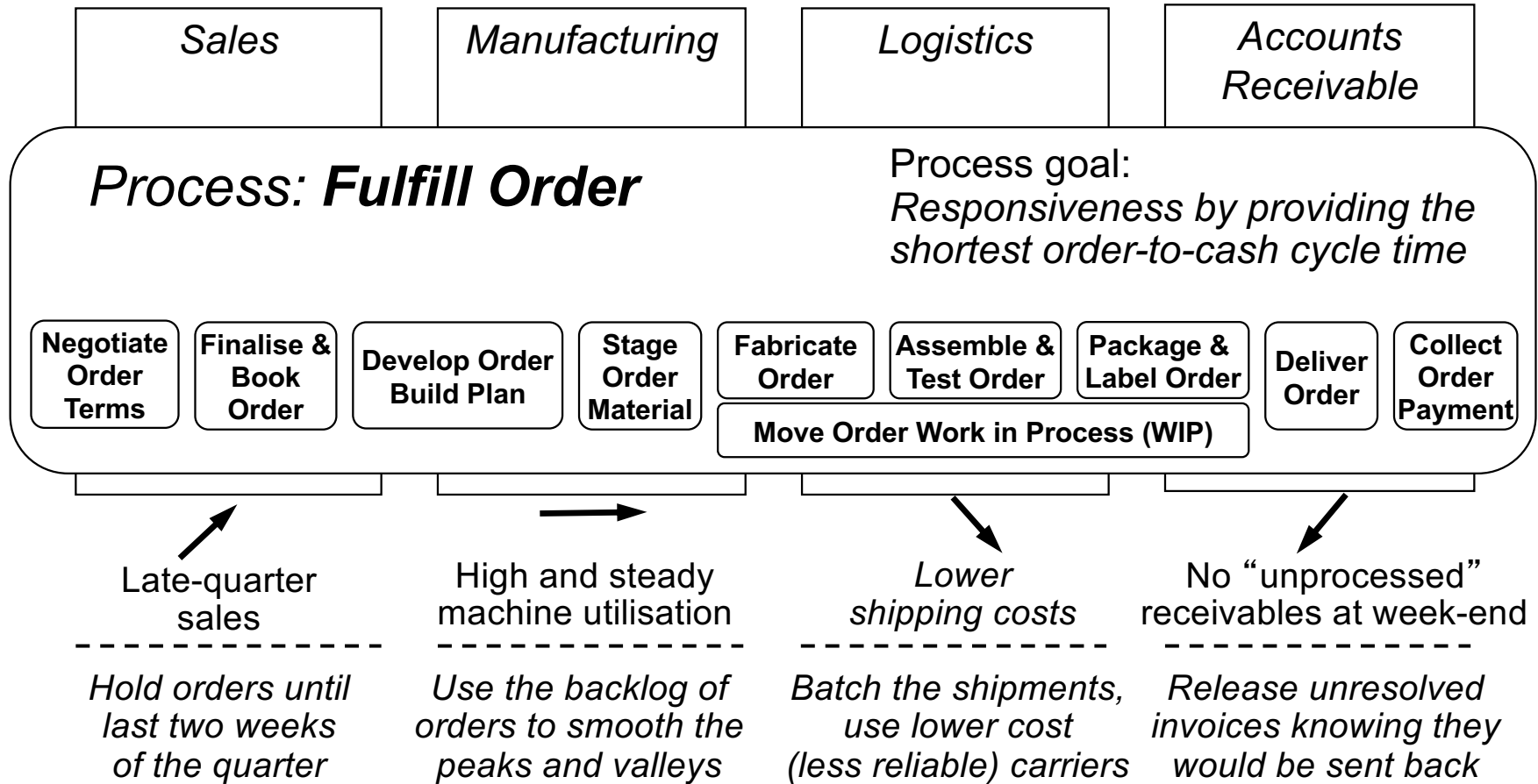

Poor performance because each function was working hard to meet uncoordinated, functional targets

This doesn't mean functions are bad!

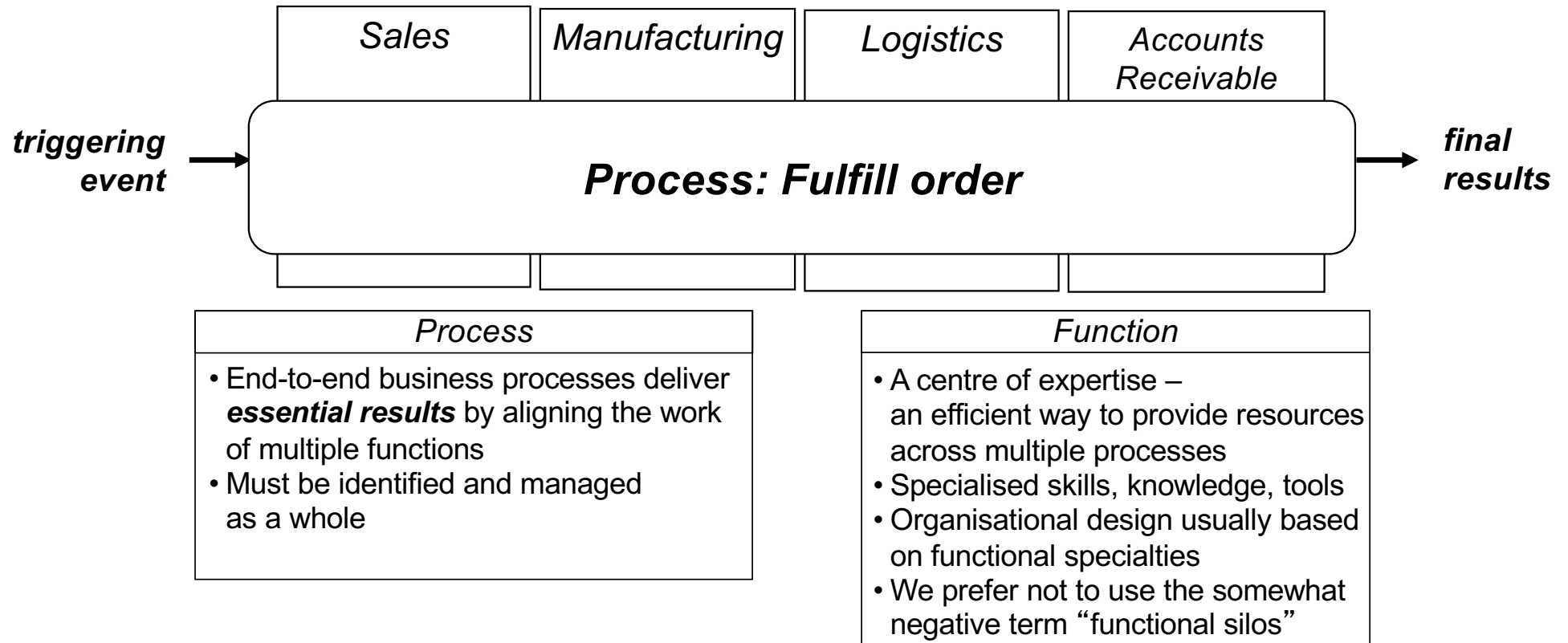

Ultimately, business processes are all about alignment

Processes and functions – three key points

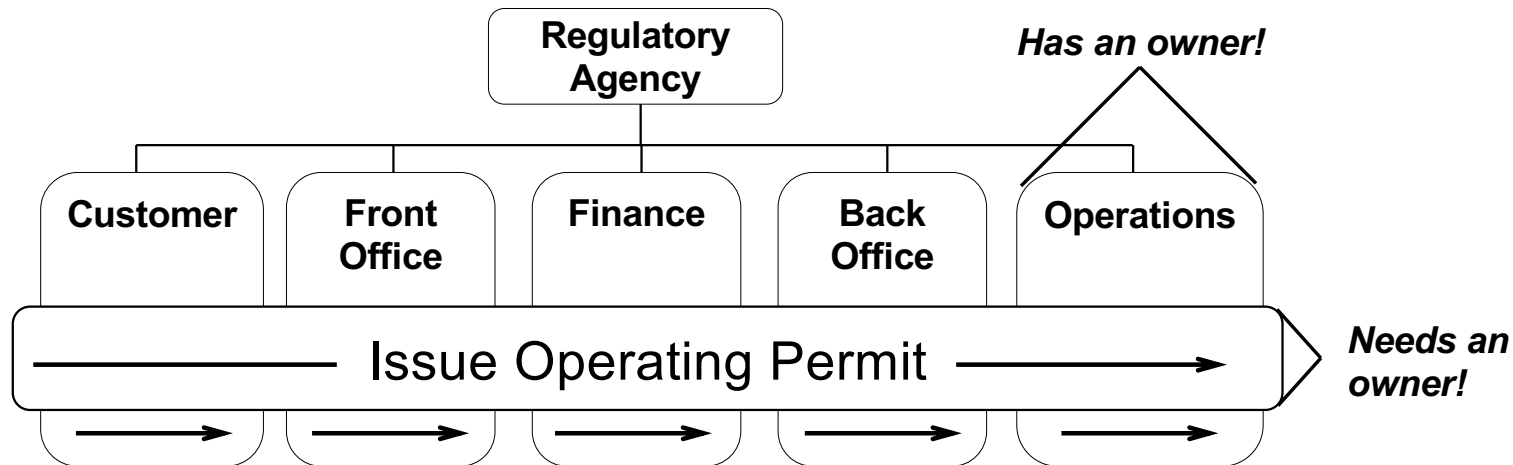

- The first step in managing processes is to *determine what they are* – they don't identify themselves
- Performance goals for the functions must *align with* (or be *balanced against*) the performance goals of the process
- Processes need an *owner / steward* to set direction, ensure alignment, and resolve conflict

It takes concerted effort – nothing happens by accident

3 – Processes and information systems

1. It is essential to have clarity on what a *business process* really is
2. Performance measures may be *functionally aligned* - work *against* business processes
3. Enterprise system implementations must include a business process perspective
4. Success with business processes requires a *holistic view* in which *six enablers* are considered
5. A business process can't be great at everything – a single *differentiator* must be chosen

“Success with SAP Implementation”

Study by the late Michael Hammer, “godfather of BPR”

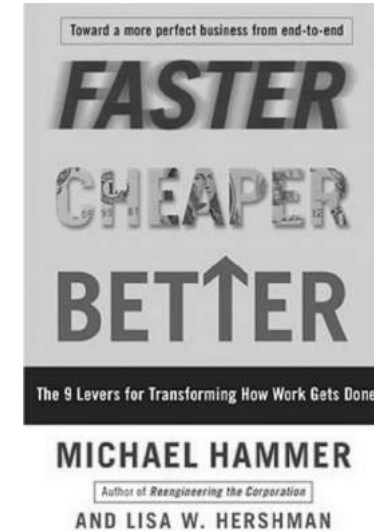
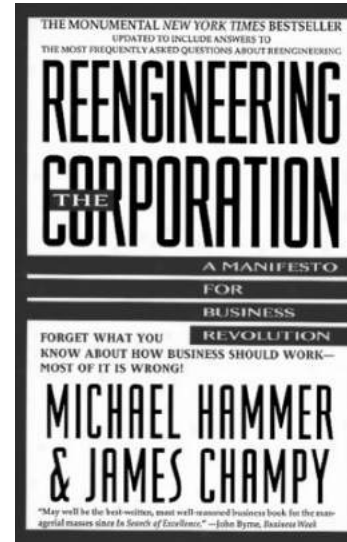

Observed that success of SAP implementations varied *wildly*

Worked with ~80 companies to assess their degree of success with SAP implementation

Success with SAP implementation

Hammer plotted the number of companies for each “success” ranking

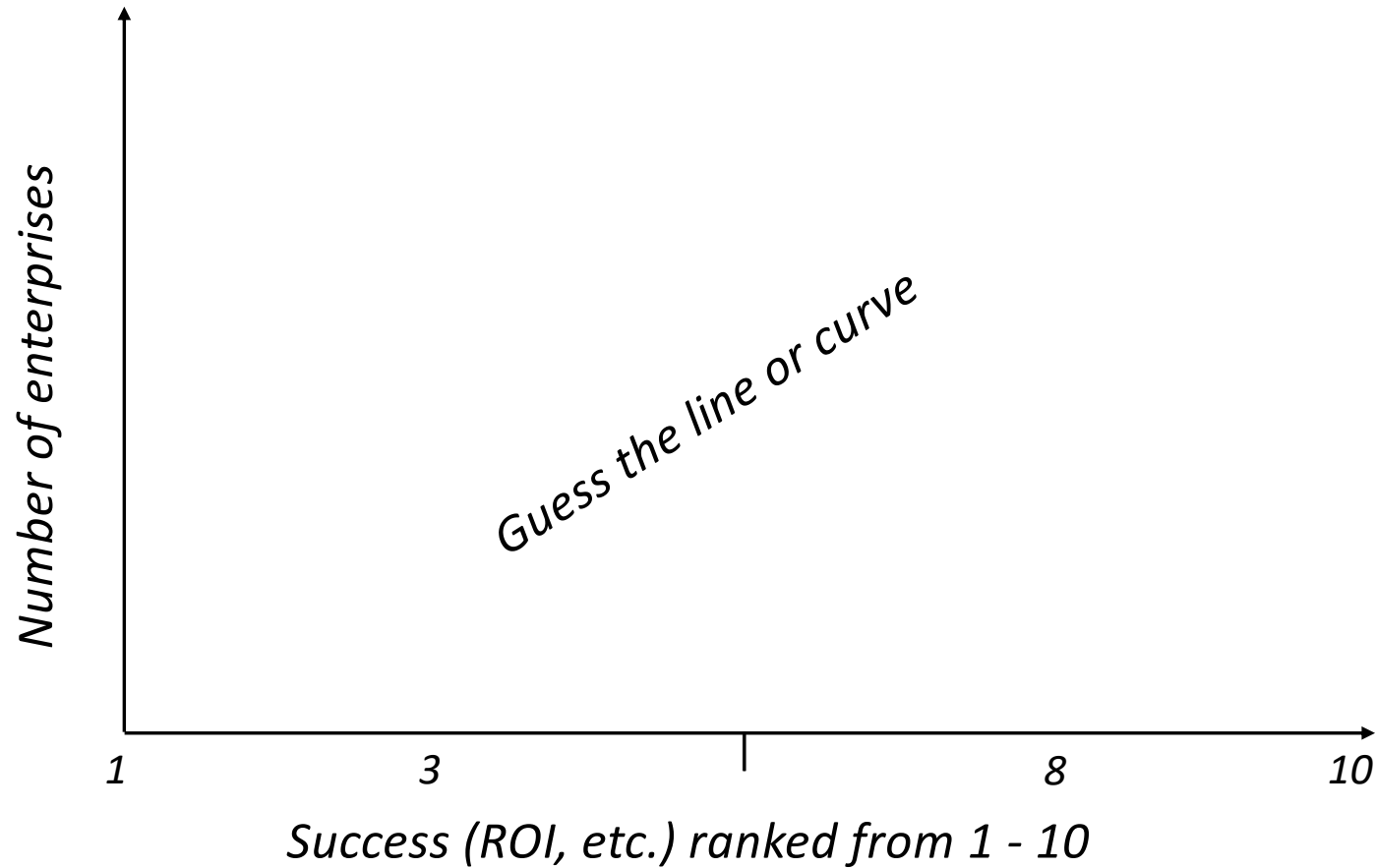

Hammer not sure what the outcome would be

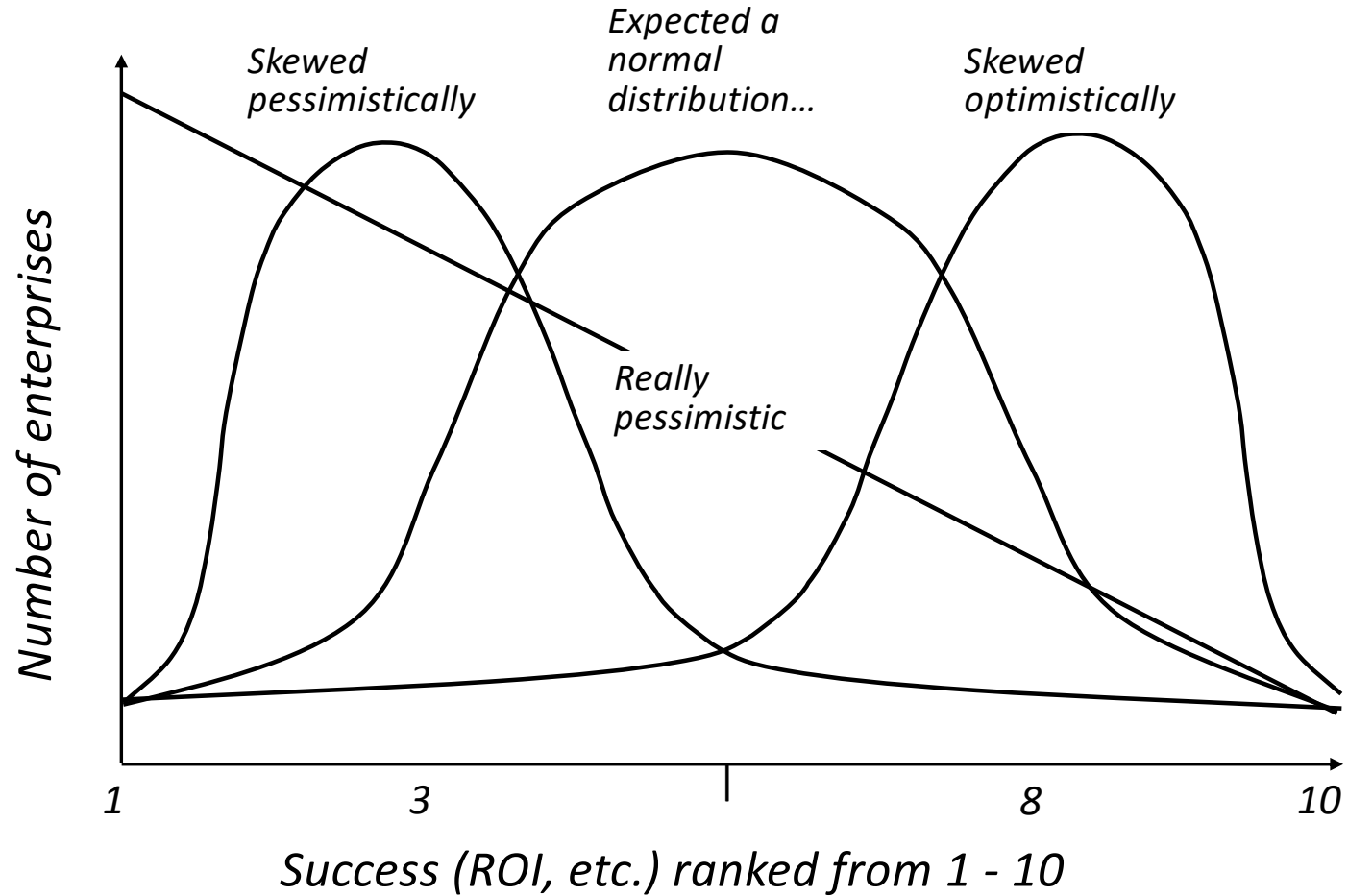

The surprising result

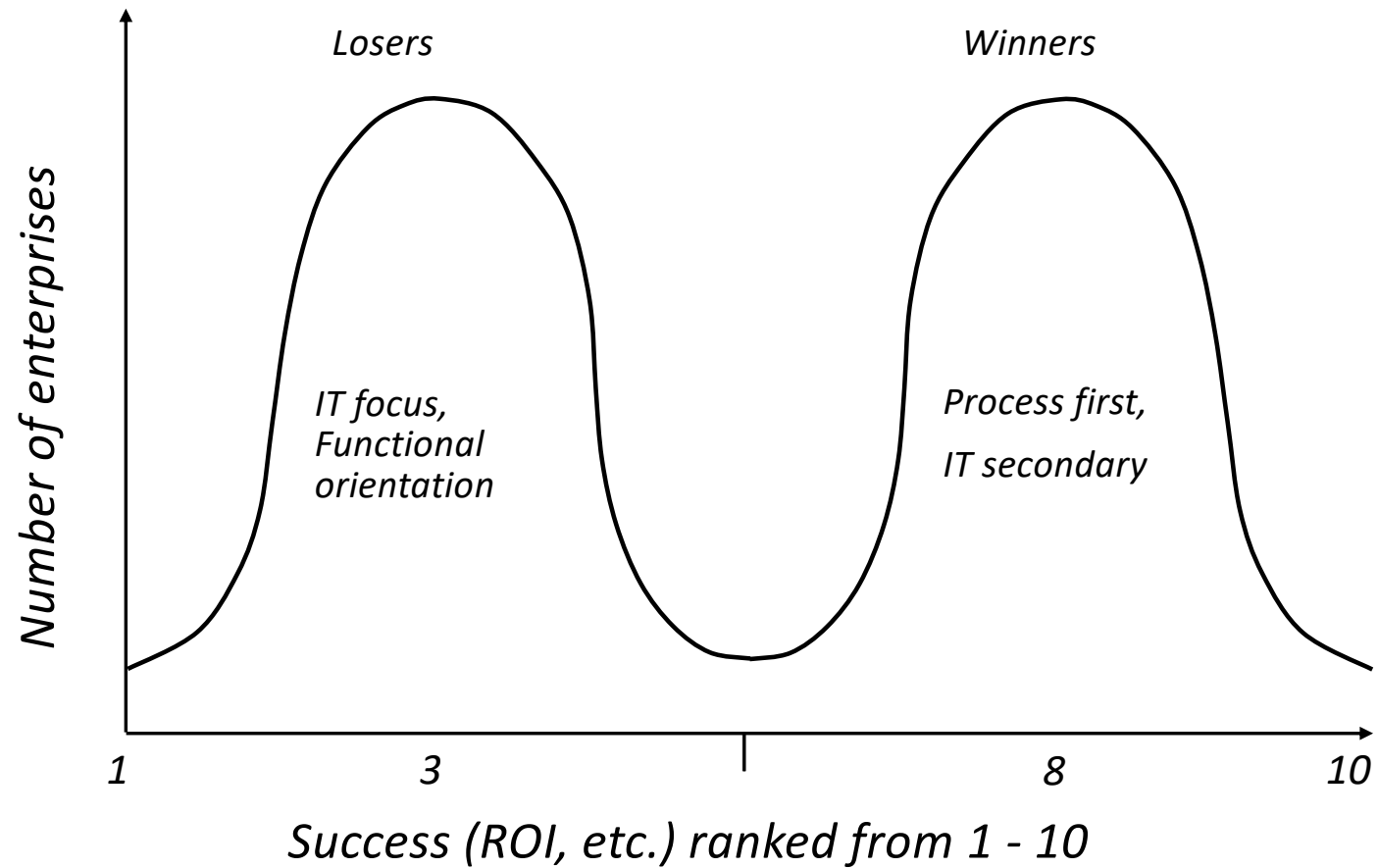

Returning to an earlier example

Global manufacturer implementing SAP

Four primary modules:

- *Sales*
- *Manufacturing*
- *Logistics*
- *Finance*

Determined to *do it right*:

“This will be a *process-oriented* implementation!”

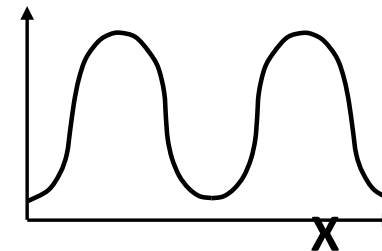

Impact of confusing function and process

Implementing SAP without clarity on “process”:

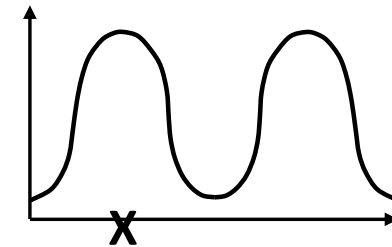
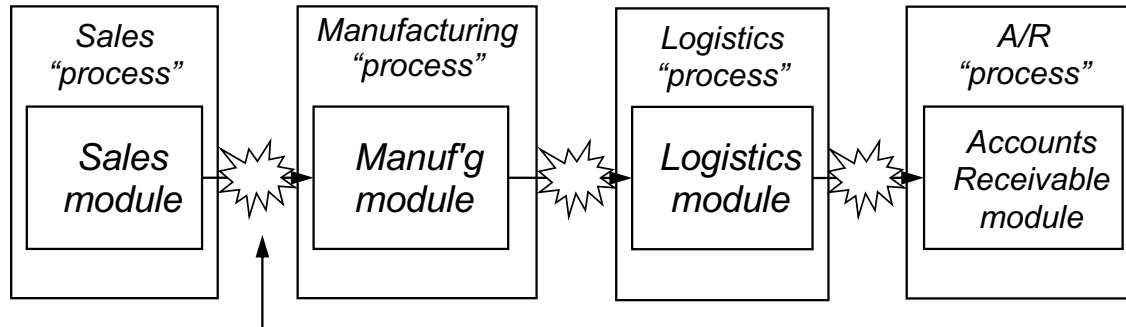

Conflicts: timing, coding, terminology, data formats, performance targets, ...

SAP re-implemented in a process-driven configuration:

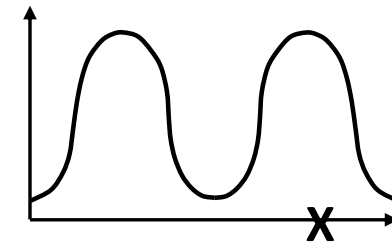
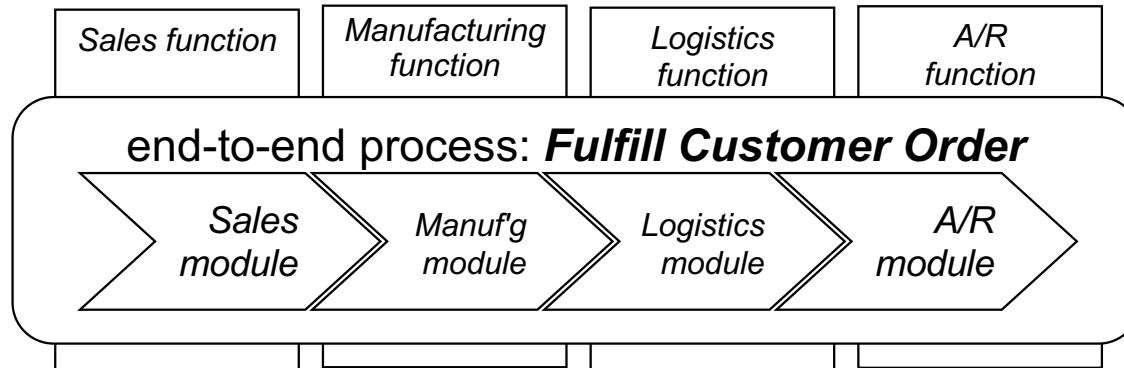

Same software, radically different outcomes

Staying “right” in an “entropic” environment

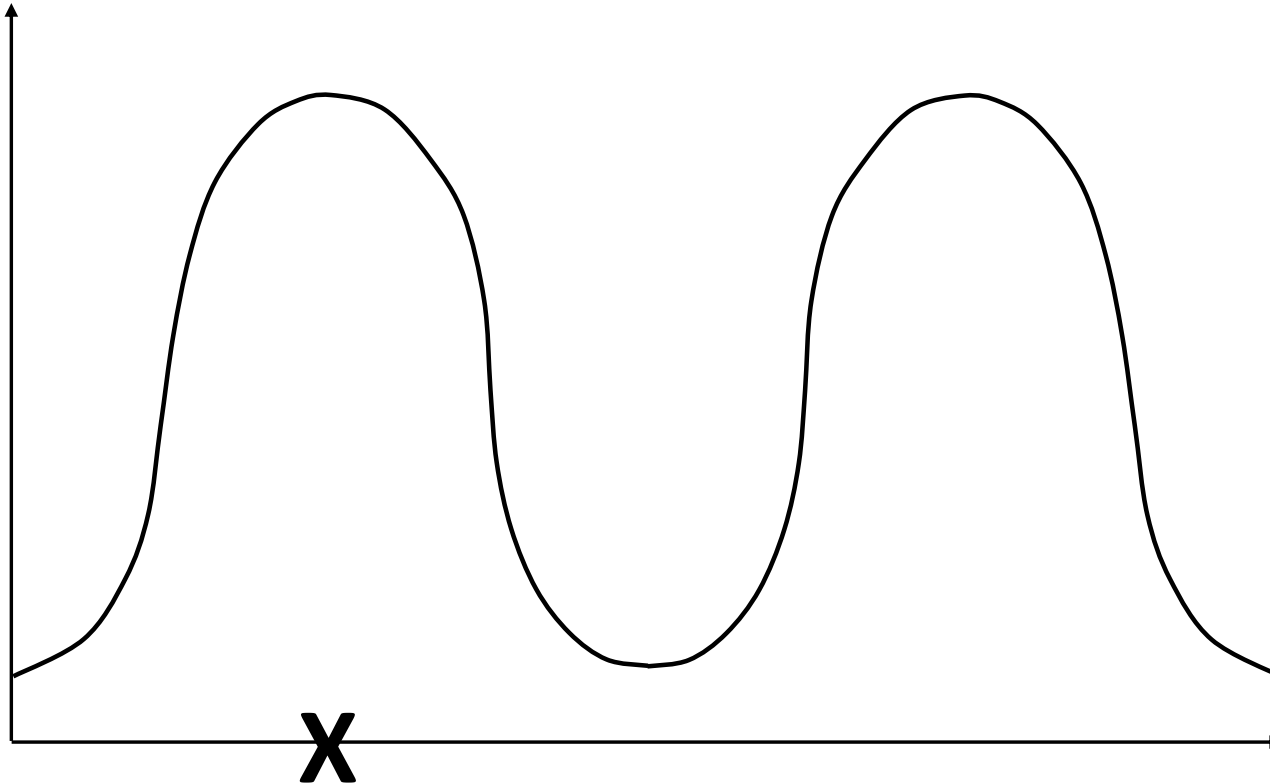

There will always be a pull back towards functional comfort

- *ongoing management of the process is critical!*
- *all enablers must be addressed for a sustainable process*

4. A holistic view for process analysis and design

1. It is essential to have clarity on what a *business process* really is
2. Performance measures may be *functionally aligned* - work *against* business processes
3. Enterprise system implementations must include a business process perspective
4. Success with business processes requires a *holistic view* in which six *enablers* are considered
5. A business process can't be great at everything – a single *differentiator* must be chosen

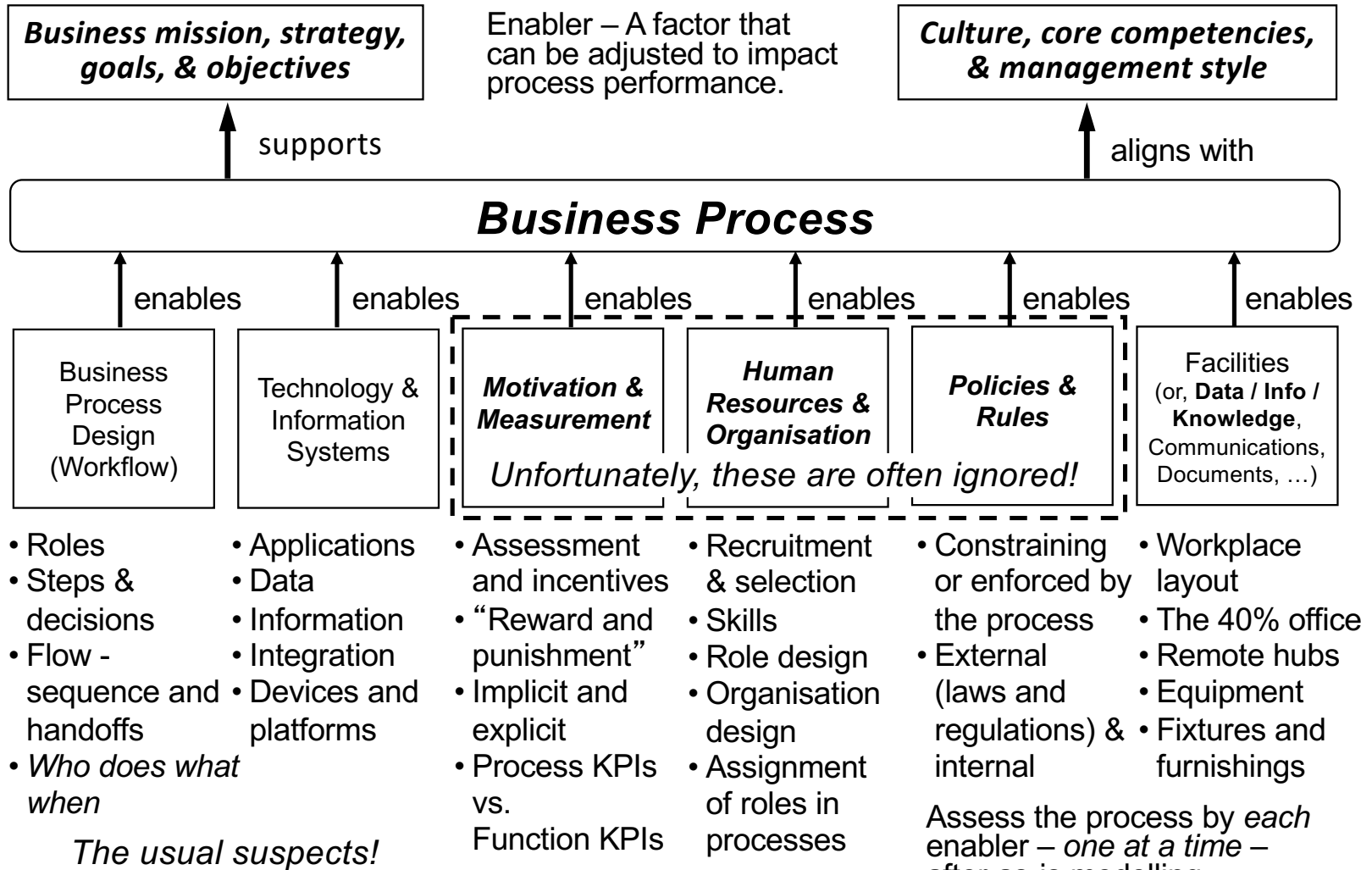

We model the as-is process to support assessment by enabler

As-is modelling maps *reality* – who, does what, when.

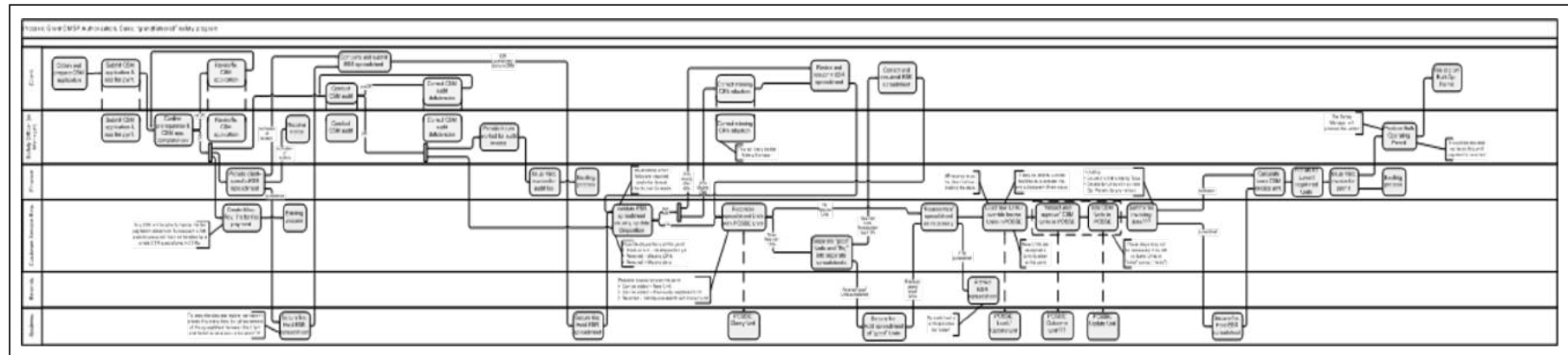

This supports a *fact-based* assessment of the *as-is* process by enabler.

<p>Process Workflow Design: Is each step adding value, placed at the right point in the process, sequential or parallel as appropriate, performed by the best role, etc.?</p>	<p>Information Systems & Technology: Are the process, the steps, and the actors supported by the right systems and technology?</p>	<p>Motivation & Measurement: How is the performance of the steps, the actors, the participating functions, and the process measured, and what are the consequences?</p>	<p>Human Resources & Organisation: Are roles suitably broad, are organisations designed properly, and are roles & skills deployed well into the process?</p>	<p>Policies & Rules: What policies or rules, whether internal or external, constrain or are enforced by the process, and what is their impact?</p>	<p>Facilities (or other): Are the layout & furnishings optimal or do they impede the process? (Many clients instead use this enabler to consider data, info, and knowledge.)</p>
--	---	--	---	---	---

5. Process goals: know your “differentiator”

1. It is essential to have clarity on what a *business process* really is
2. Performance measures may be *functionally aligned* - work *against* business processes
3. Enterprise system implementations must include a business process perspective
4. Success with business processes requires a *holistic view* in which six *enablers* are considered

5. A business process can't be great at everything – a single *differentiator* must be chosen

As noted, this is one of the things I do on ~100% of *Project Recovery* assignments -

1. Build *Process Scope Model & Process Summary Chart*
2. Develop *Case for Action* – an *As-Is Assessment by Stakeholder*
3. Establish the *Differentiator*
4. (Optionally conduct an *As-Is Assessment by Enabler*)

Great processes don't try to be all things to all people – strive to be **great** at one differentiator, and **good** at the other two...

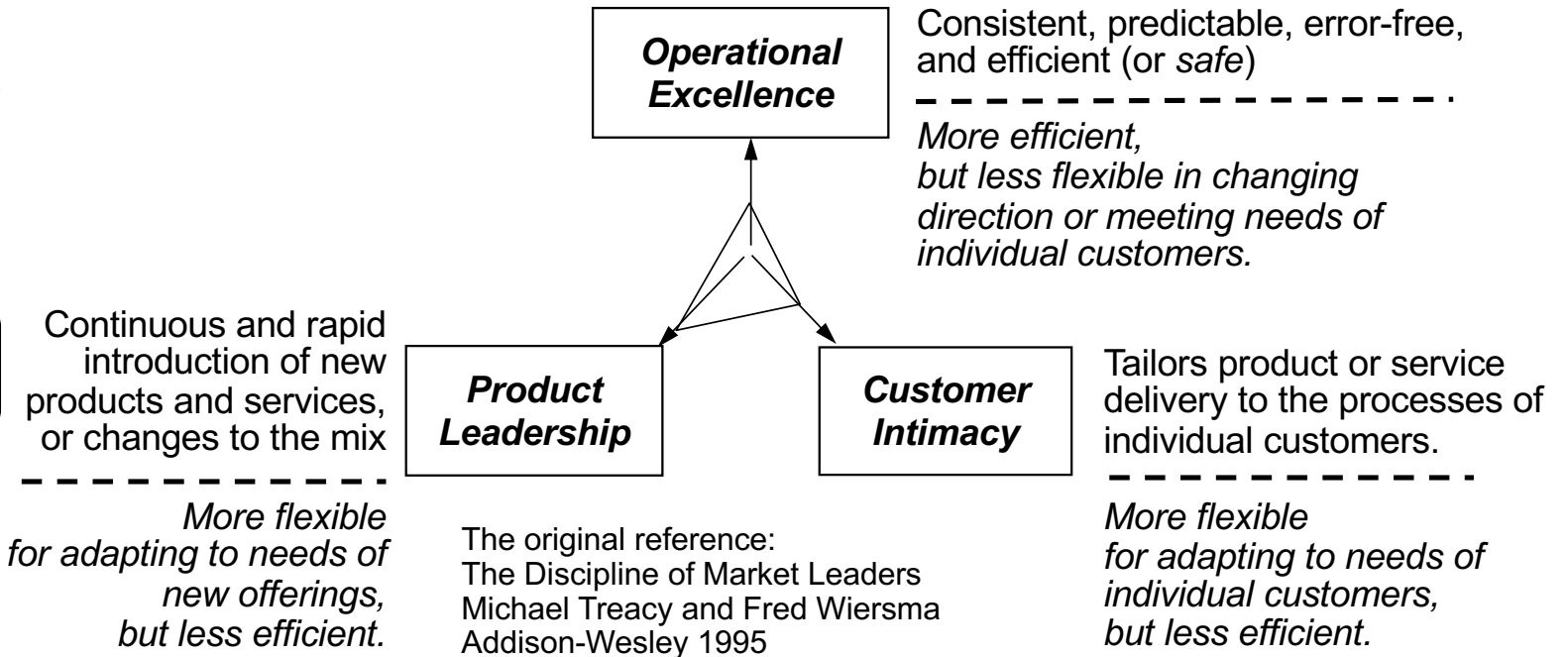

1. Concept developed for the entire enterprise, but excellent for individual processes – a “signpost” for decisions on process changes.
2. Processes in an enterprise do not all have the same differentiator.
3. The Process Differentiator can change over time – *slowly!*

Example: “differentiator confusion”

Getting it wrong can be *expensive...*

- Insurance company recruits CEO from high tech industry
- New CEO decides “innovation is everything” – \$100M spent on process redesign and system development in support of “innovative car insurance products” – *Product Leadership*
- Total failure – customers wanted affordable, easy to understand, easy to buy insurance – *Operational Excellence (Op Ex)*

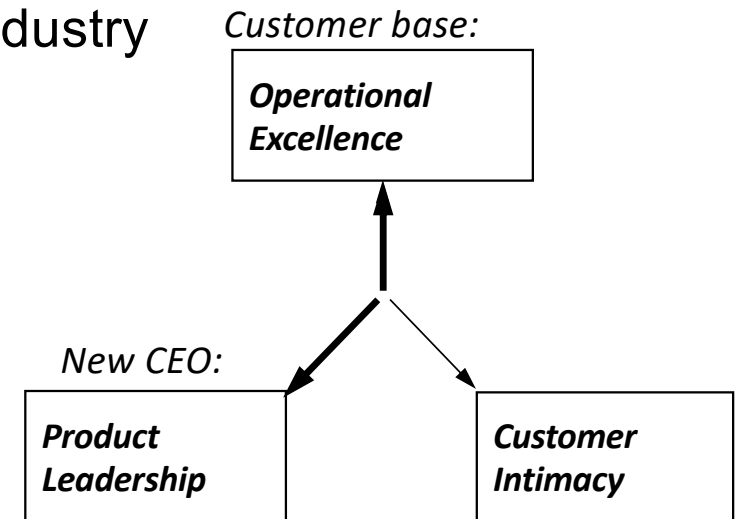

Three common differentiator problems

1. Focus on the wrong differentiator – *customer alienation*
2. No differentiator or trying to excel at *multiple* differentiators – *stressed workforce and lower performance*
 - *Operational excellence* – “We must be the low-cost provider!”
 - *Customer focused* – “We must do what it takes for each client!”
3. Conflicting differentiators within functions of a process – *lower performance*

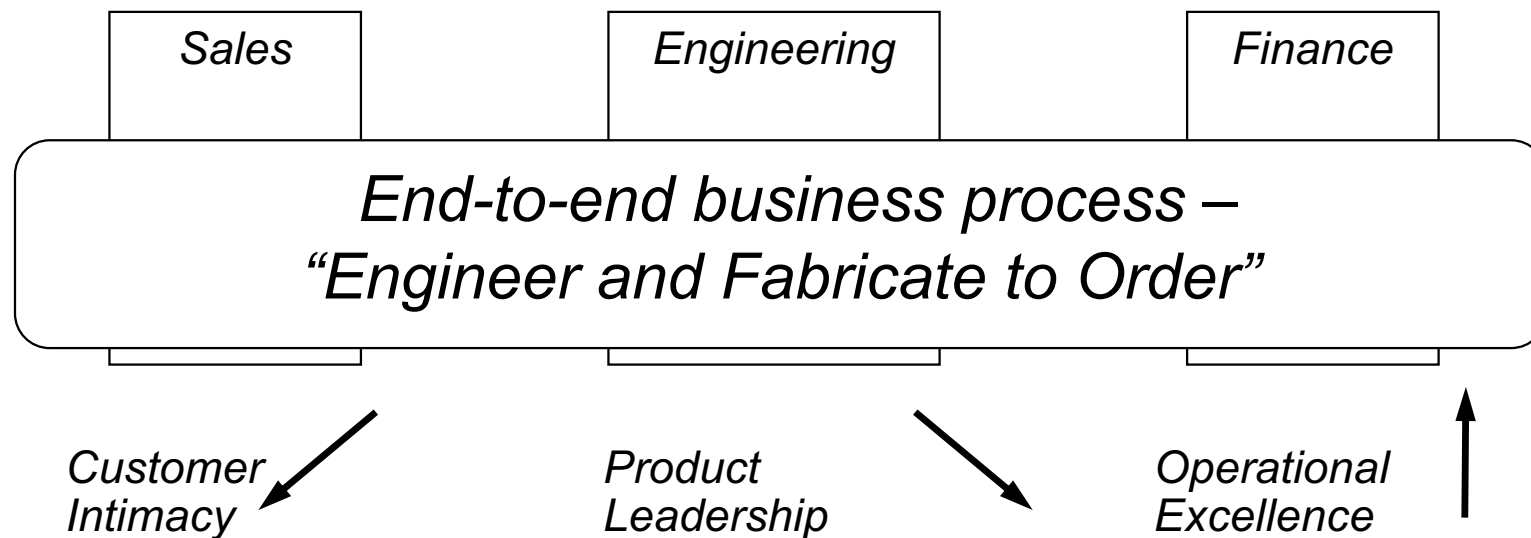
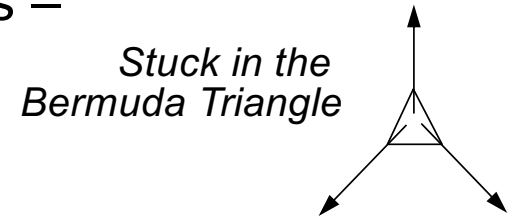

Business Process – part of the Clariteq framework for Business Analysis

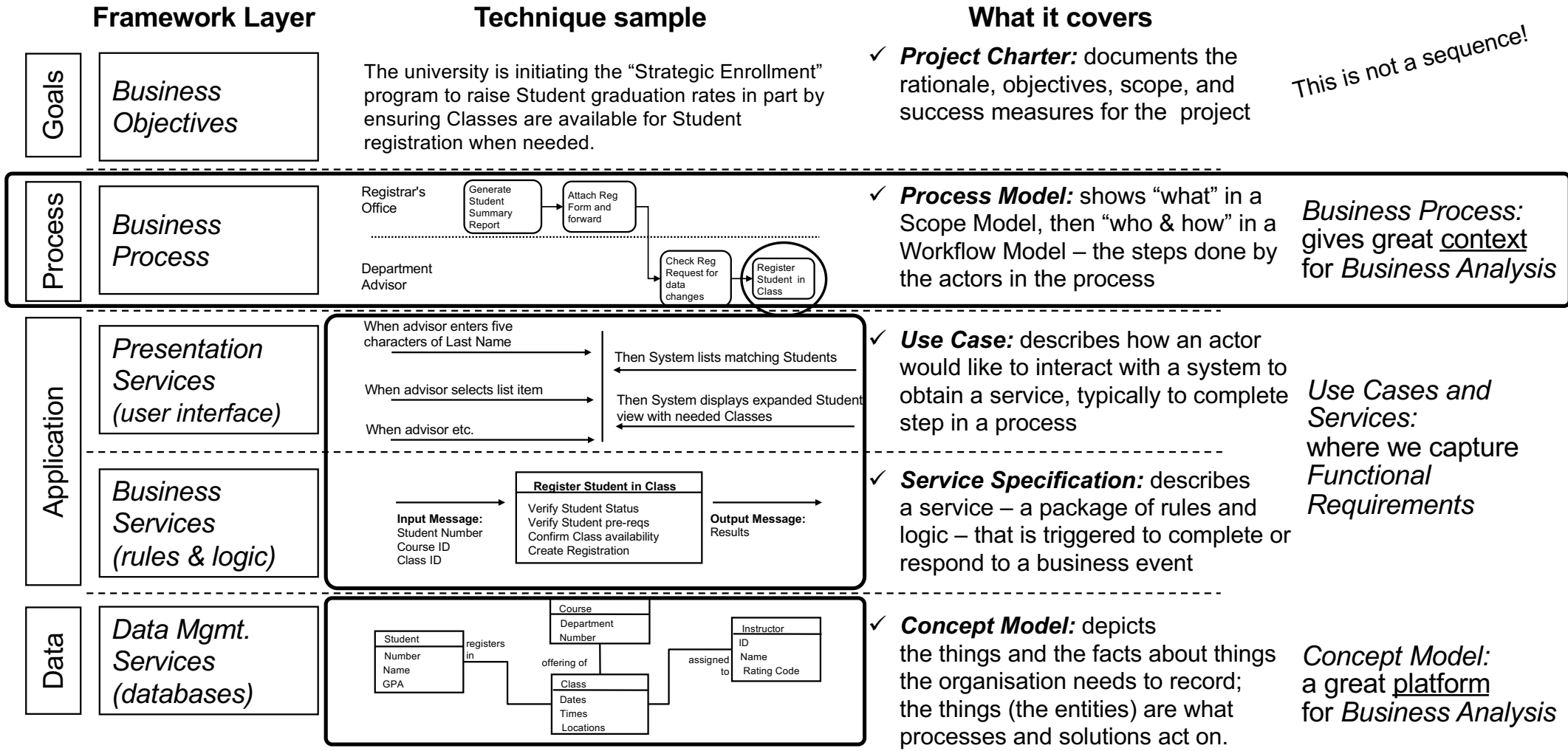

This is not a sequence!

Business Process: gives great context for *Business Analysis*

Use Cases and Services: where we capture *Functional Requirements*

Concept Model: a great platform for *Business Analysis*

Only four types of models vs. 14 in the UML! (Unified Modelling Language)

Key point! Everything relies on the concept model

All use the language and constraints of the Concept Model (the “thing model”) – the ultimate “what”

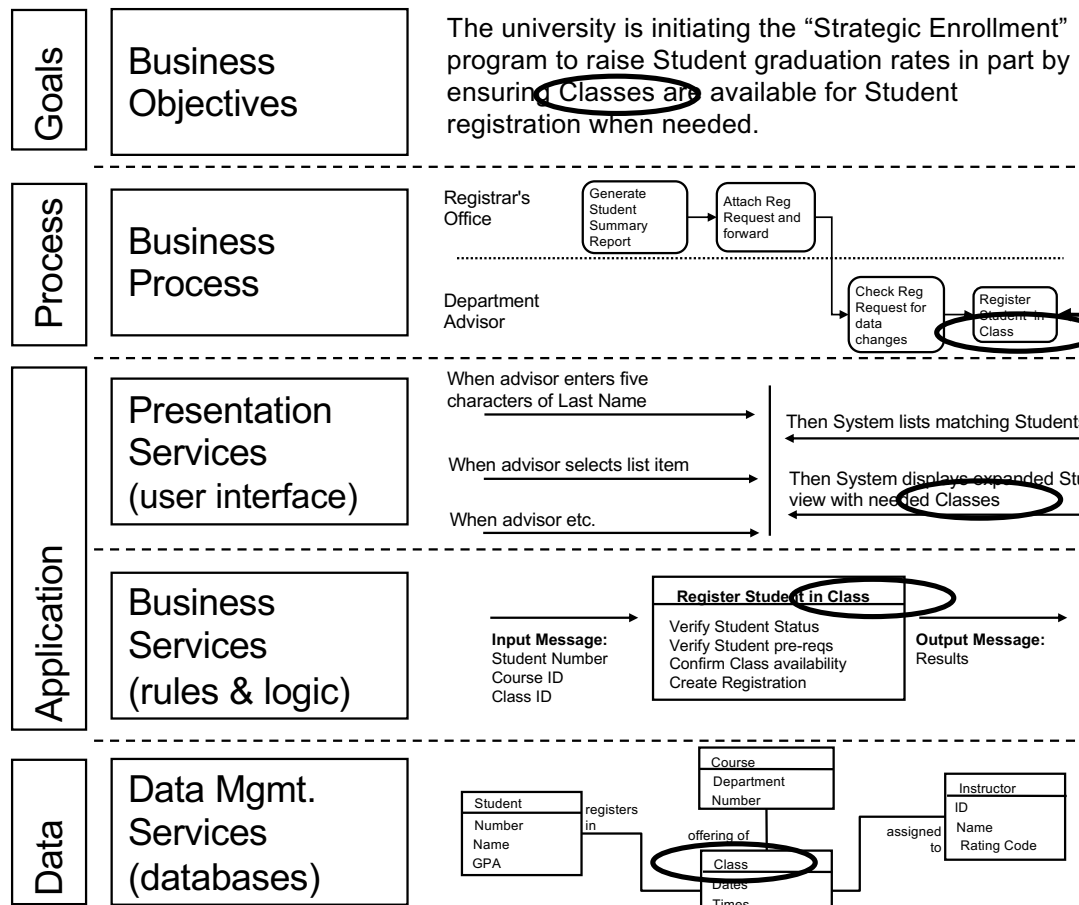

Use Cases/User Stories:
- Who (Actors) needs access to the Services, and how (Platform)?

Verb-Noun pairs:
- The Services (event-handlers) that are at the heart of a Service Oriented Architecture.
- Also "building blocks" of Business Processes

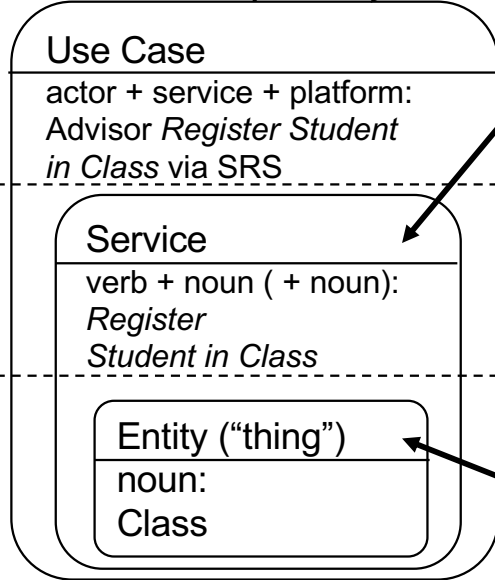

The core Nouns in your enterprise. Also known as Business Objects.

Bonus – great starting point to discover your Events/Services and Use Cases/User Stories

Another key point! Different levels of detail for different purposes

Different models and levels of detail for different audiences and purposes.

Scope –
for Planning

Concept –
for Understanding

Detail –
for Specification

Also applies to Use Cases, Services, and Data Models

- Augmented Scope Model showing next level activities: *who - what - how*
- “Business-friendly” (just boxes & lines) flow models to maximise communication and participation
- Two levels – *Handoff and Service*

- Detail for technical design, perhaps using full BPMN

Process Landscape (optional):

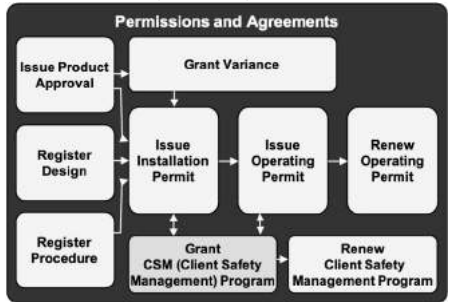

Process Scope Model:

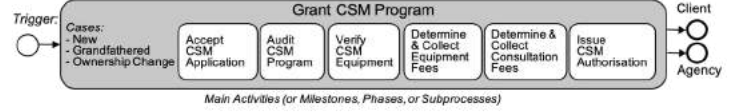

Process Summary Chart:



Boxes

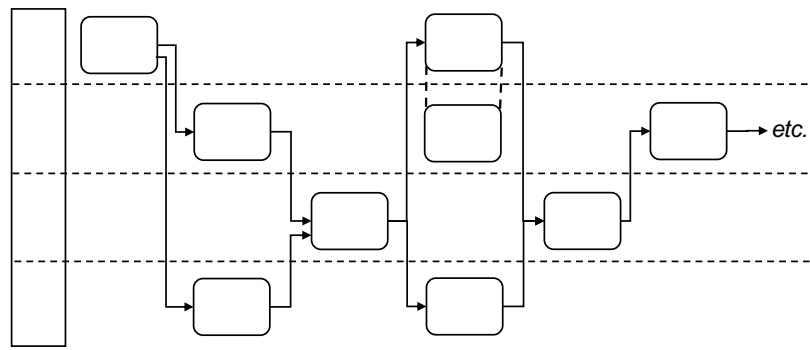

Boxes & Lines

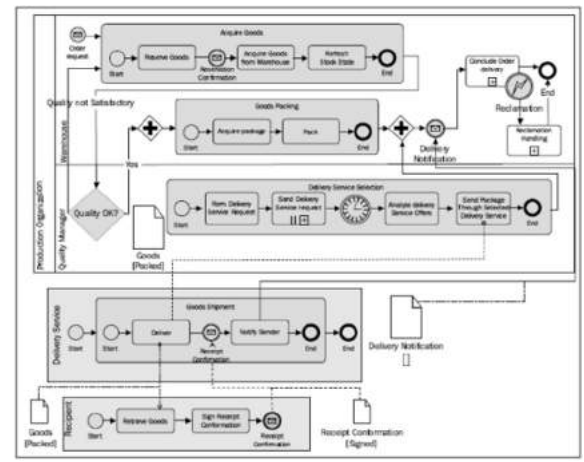

Boxes, Lines,
& MANY Symbols

Specifics on progressive detail for all techniques

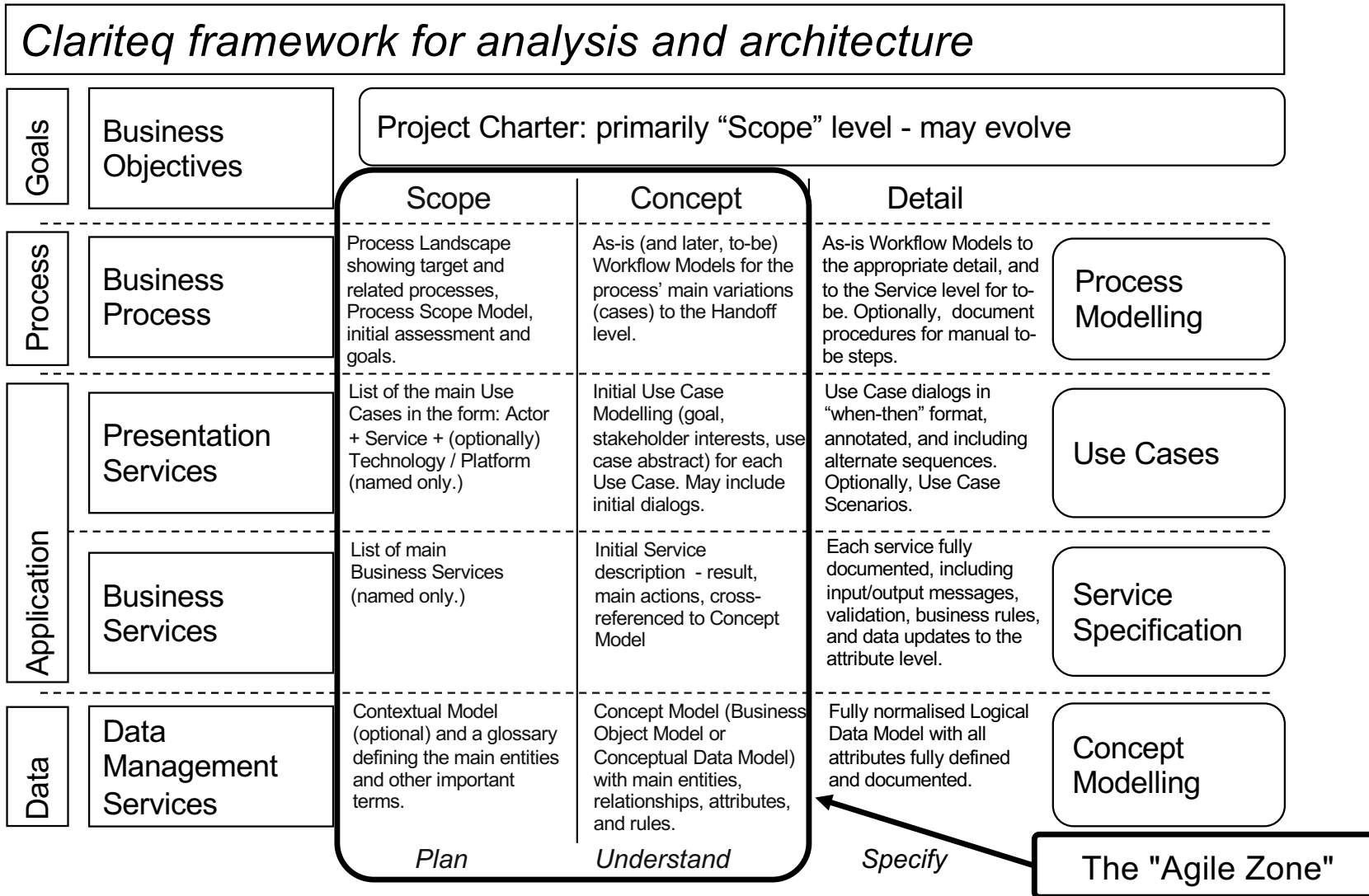

Our three-phase methodology – proven, practical, & agile



Goal or issue, not rigorously specified

Identify & scope the process with a *Scope Model* & a *Process Summary Chart*; Optional - build a *Concept Model*

Complete **initial as-is process** assessment, and **to-be objective** setting, by stakeholder

Perform more **detailed as-is process** analysis:
- *Augmented Scope Model*
- Optionally, draw *workflow*

Complete **final as-is process** assessment by enabler, and generate **to-be improvement ideas**

Refine **to-be improvement ideas**, determine **5–10 key features** of the to-be process

Assess each **to-be feature by enabler** to determine changes to make it sustainable

Design to-be process:
1 - **essential** activities first
2 - "who & how"
3 - transport & protocol

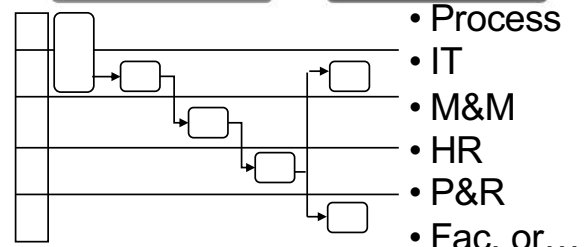
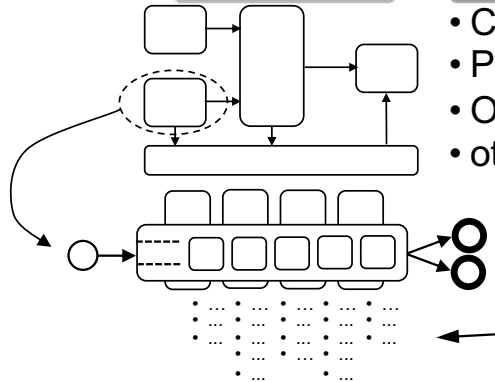

Re-think!
• Select key to-be Features

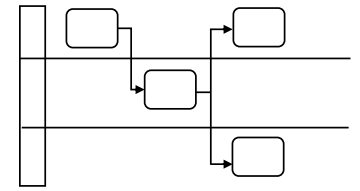

- ID processes & draw *Process Landscape* (Optional – only if you have a large scope)
- ID Trigger, Results, main Activities, Cases (**TRAC**) & draw *Process Scope Model* – focus on *what*, no reference to *who* or *how*
- ID involved functions & mechanisms (*who* and *how*) & draw *Process Summary Chart*
- Conduct *stakeholder-based assessment*

- Develop *as-is* models:
 - *Augmented Scope Model* – add ~5 – 7 more detailed Activities for each main Activity
 - (Optional) *as-is Workflow Models* – only enough detail to understand process behaviour
- Conduct *enabler-based assessment* and identify *potential improvements*

- Process
- IT
- M&M
- HR
- P&R
- Fac. or...

- Assess each key Feature by enabler
 - Identify and sequence *essential* activities
 - Develop *to-be Workflow Models* depicting the future *who* and *how*
 - ...on to requirements definition and implementation

Our methodology – three responses to three common difficulties

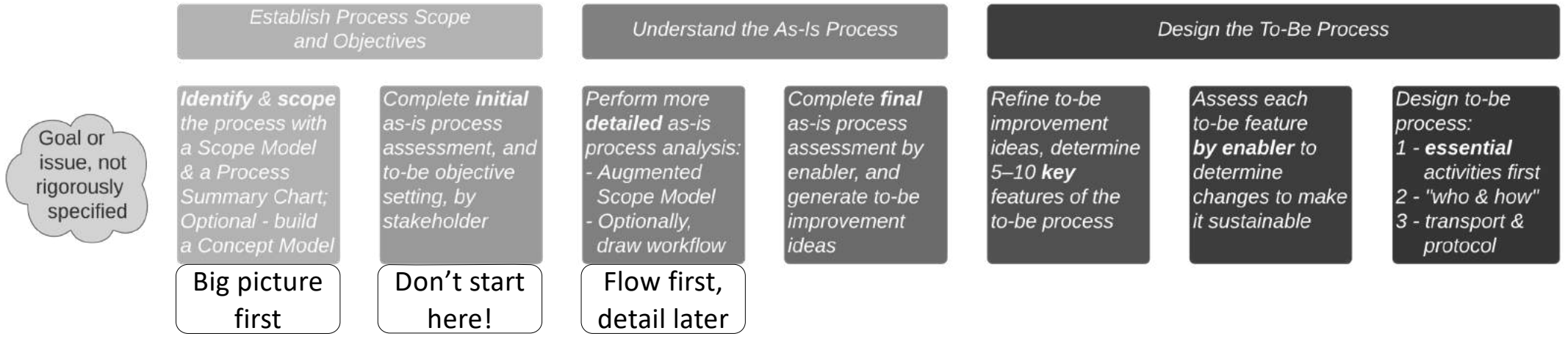

My hardest assignments

- 1 – Premature diagnosis of the situation
- 2 – Failure to identify true end-to-end processes
- 3 – A rapid descent into unhelpful detail

Don't start with a problem statement!
There will be some goal or issue, but don't formalise it **yet**.
And remember... it may not be a "process" issue. **Why not?**

Rigorous techniques to identify real business processes – a Process Scope Model and a Process Summary Chart make scope and context visible.

Clarify the big picture, then take a *controlled* descent with well-defined levels of detail.

Our methodology – two points highlighted by clients

Goal or
issue, not
rigorously
specified

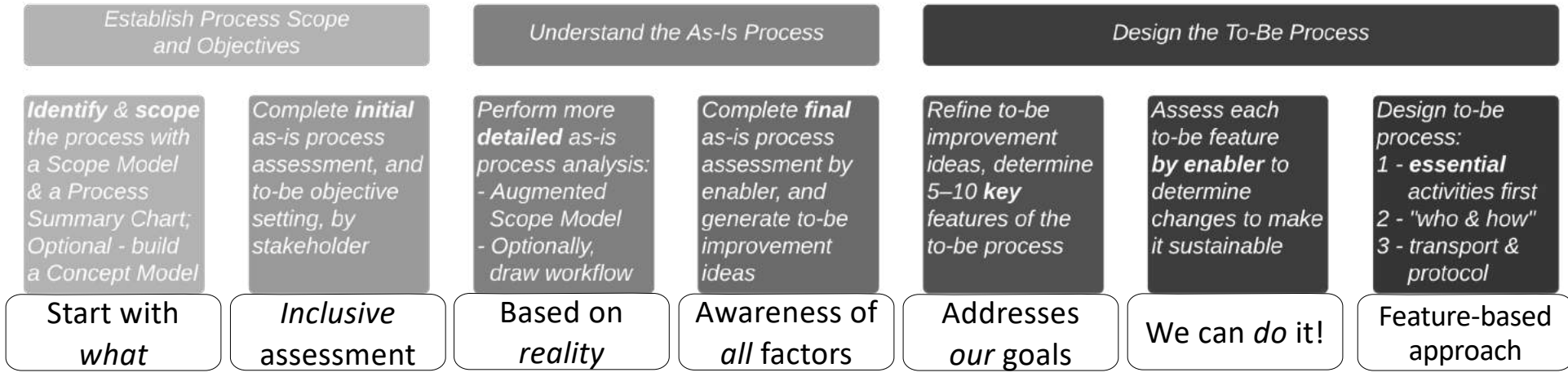

Builds support for change

Not a "big bang" – an effective, implementable, sustainable business process

"We like the way support for change is built in *throughout* your approach, not bolted on at the end."

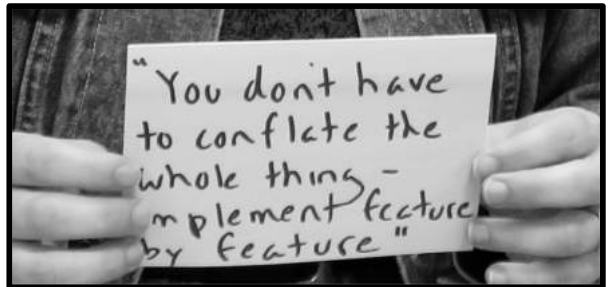

Feature-based approach makes it Agile / iterative.

And fast! – up-front work avoids endless rehashing later

Five key points plus a BA framework plus a methodology

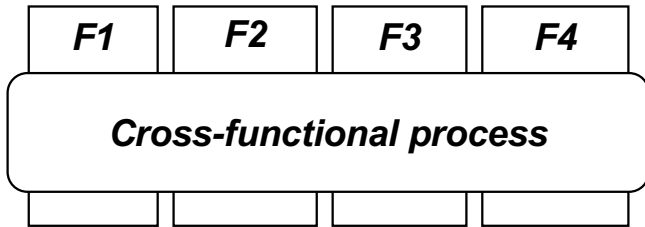

Processes:
"large" and X-functional

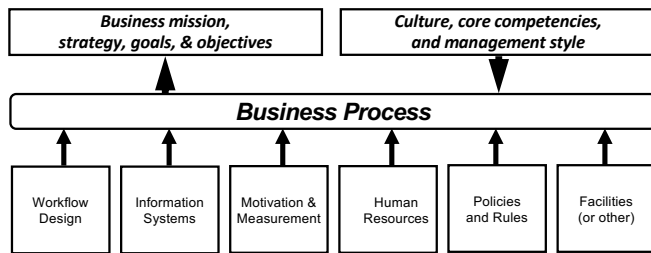

Holistic method

...and a proven
Methodology

Goal or
issue, not
rigorously
specified

Establish Process Scope
and Objectives

Identify & scope
the process with
a Scope Model
& a Process
Summary Chart;
Optional - build
a Concept Model

Complete initial
as-is process
assessment, and
to-be objective
setting, by
stakeholder

Understand the As-Is Process

Perform more
detailed as-is
process analysis:
- Augmented
Scope Model
- Optionally,
draw workflow

Complete final
as-is process
assessment by
enabler, and
generate to-be
improvement
ideas

Design the To-Be Process

Refine to-be
improvement
ideas, determine
5-10 key
features of the
to-be process

Assess each
to-be feature
by enabler to
determine
changes to make
it sustainable

Design to-be
process:
1 - essential
activities first
2 - "who & how"
3 - transport &
protocol

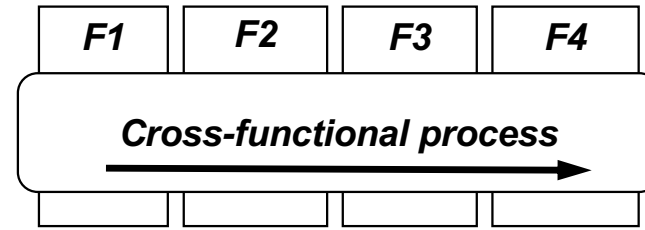

Misaligned measures

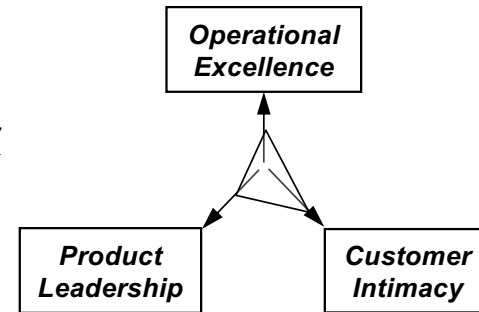
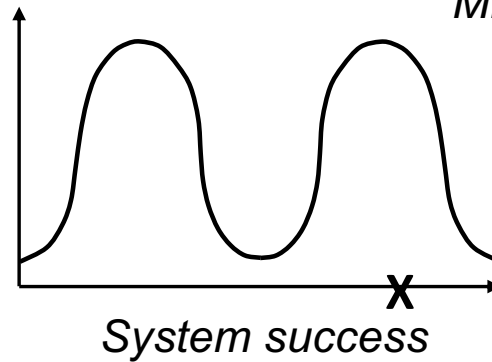

Differentiator

Model-driven
framework

Process
Modelling

Use Cases

Service
Specification

Concept /
Data
Modelling

Identifying and Scoping Business Processes

1. Communicating the fundamentals of *Business Processes*

2. Identifying true, end-to-end, cross-functional
Business Processes

3. Developing a *Process Architecture*

4. Seven ways to help people embrace *Process Change*

5. *Human-oriented* process modelling

6. A feature-based *Process Design* method –
transitioning from *as-is* to *to-be*

Identify & scope process(es)

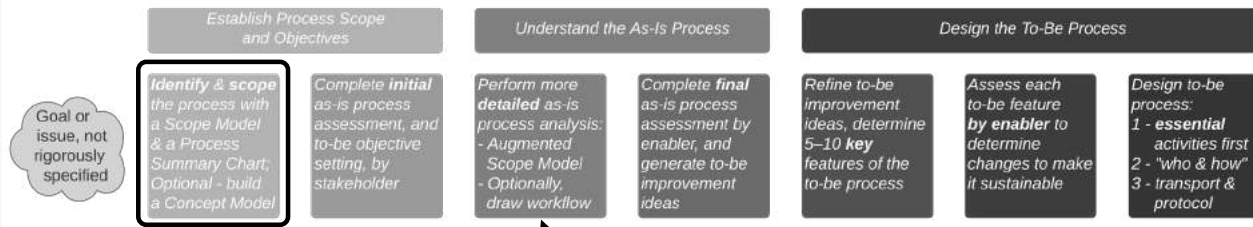

Clarify scope and context

I used to dive in here... lots of issues!

Whether it's a new initiative or "project recovery," **always:**

- Develop a Process Scope Model

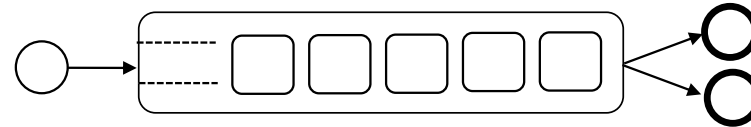

- Develop a Process Summary Chart

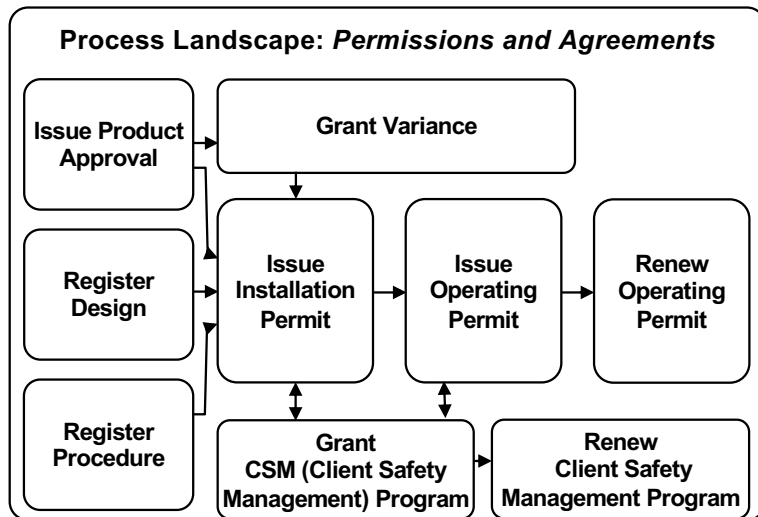
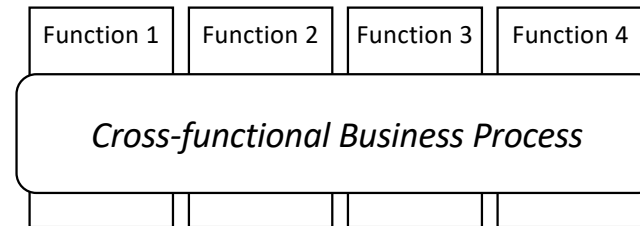

You *might* start at a higher level, with a **Process Landscape** – a decomposition of a business area into a family of *individual business processes*

Process discovery example

A bank believed they had identified the 12 *business processes* in their Commercial Loans Management area, including these 7:

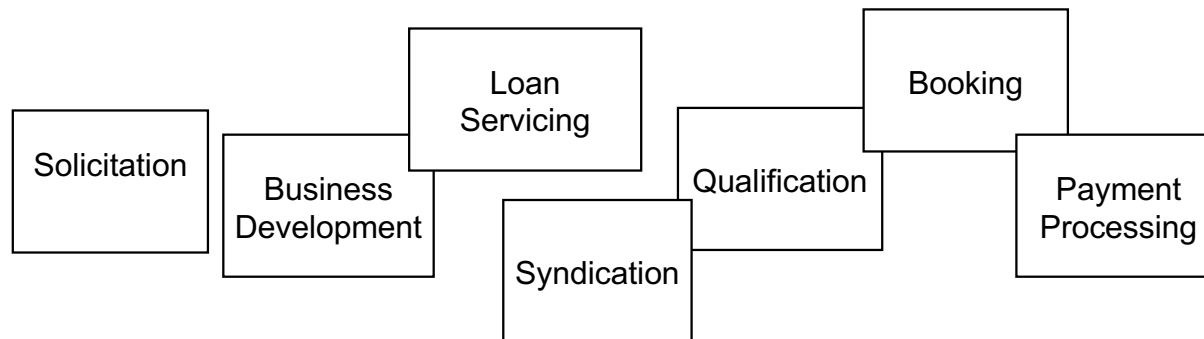

Discuss:

- What is wrong with the names of these processes?
- Can you think of any questions to help improve these process names?

Bottom-up process discovery – example

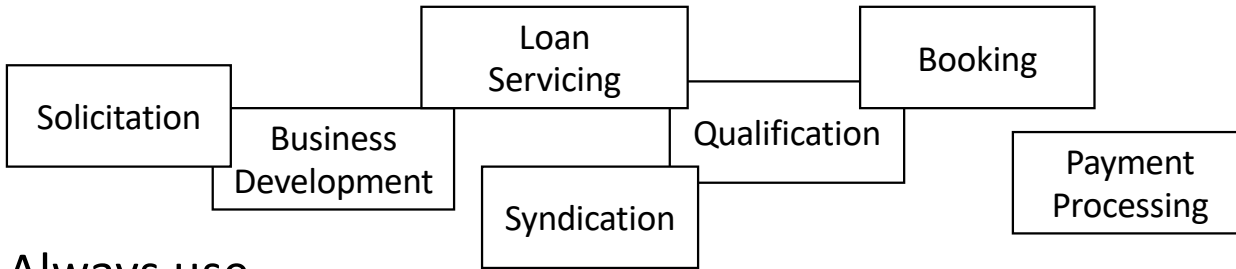

Dubious “business processes”

Always use
“active verb – noun” naming
with no “who and how”

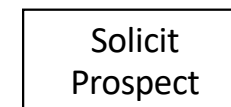
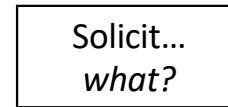

Client then identified *recognisable* activities, each producing an essential *result* (easy!)

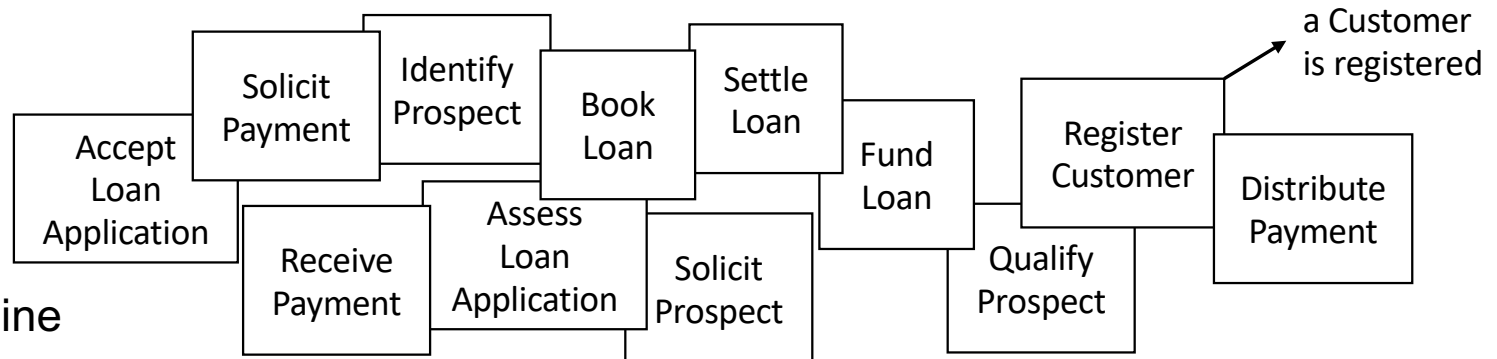

Let's put these
in sequence, then
use *TRAC* to determine
Business Processes.

This was done in-person with Post-its and flipcharts
but tools like Lucidchart and Miro work well virtually

Summary – sequence activities

Not usually linear – parallel chains are typical

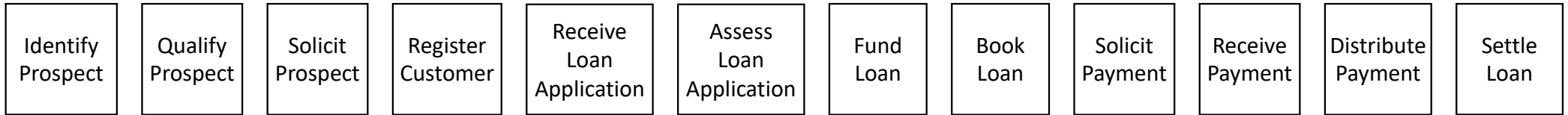

The clients arranged the activities in sequence:
- *easy!*
- *a learning experience!*

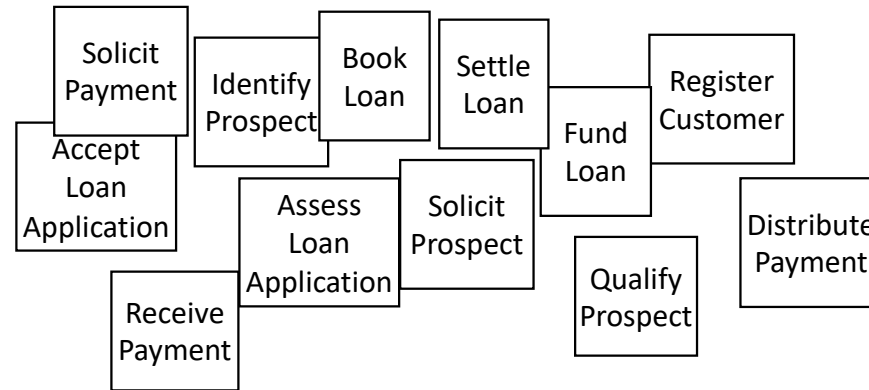

Now we'll use my "TRAC" framework for business processes –

- *Trigger*
- *Results*
- *Activities*
- *Cases*

Summary – use TRAC to discover business process boundaries

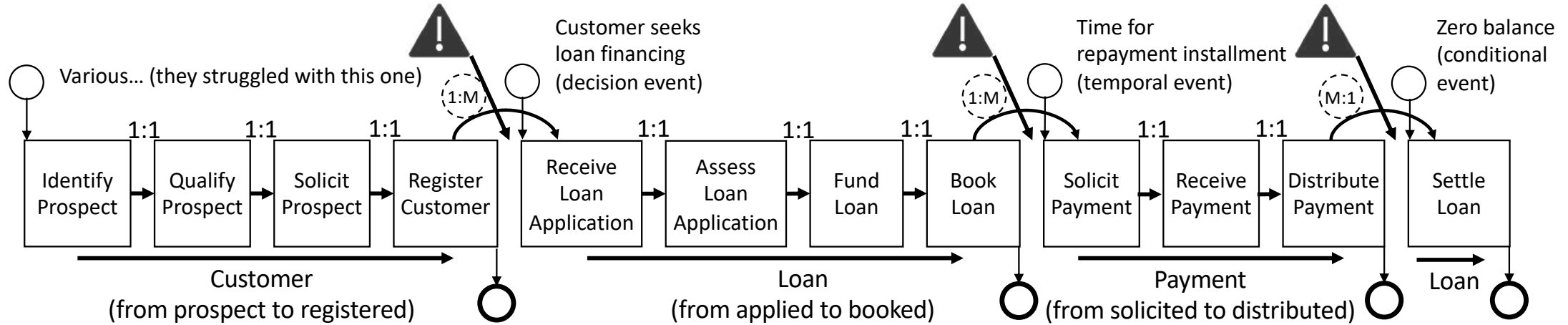

It appears we have discovered four business processes, each with:
Trigger
Results
Activities
(Cases later)

Customer:
an Account that enables business with the bank
The Bank:
a new Customer (an asset)
Business Development:
Commission credit

Customer:
Loan funds available
The Bank:
a performing asset (Loan)
Syndication Partners:
a share of the Loan

Bank:
Loan payment received & distributed
Syndication Partners:
Loan Payment received
Customer:
release of Loan liability
The Bank & Syndication Partners:
completed Loan
Regulator:
Loan completion notice

1. ID where a final Result of value is delivered to one or more (usually at least two) stakeholders – “happiness points”
2. Identify points where a Triggering event (decision, time, condition) beyond the organisation’s control is required before activities can proceed
3. Identify “cardinality” of connections between Activities (1:1, 1:M, M:1)
4. Identify “tokens” flowing through the activities
5. Name business processes with active verbs and nouns (usually the tokens)

Four end-to-end business processes, objectively demonstrated

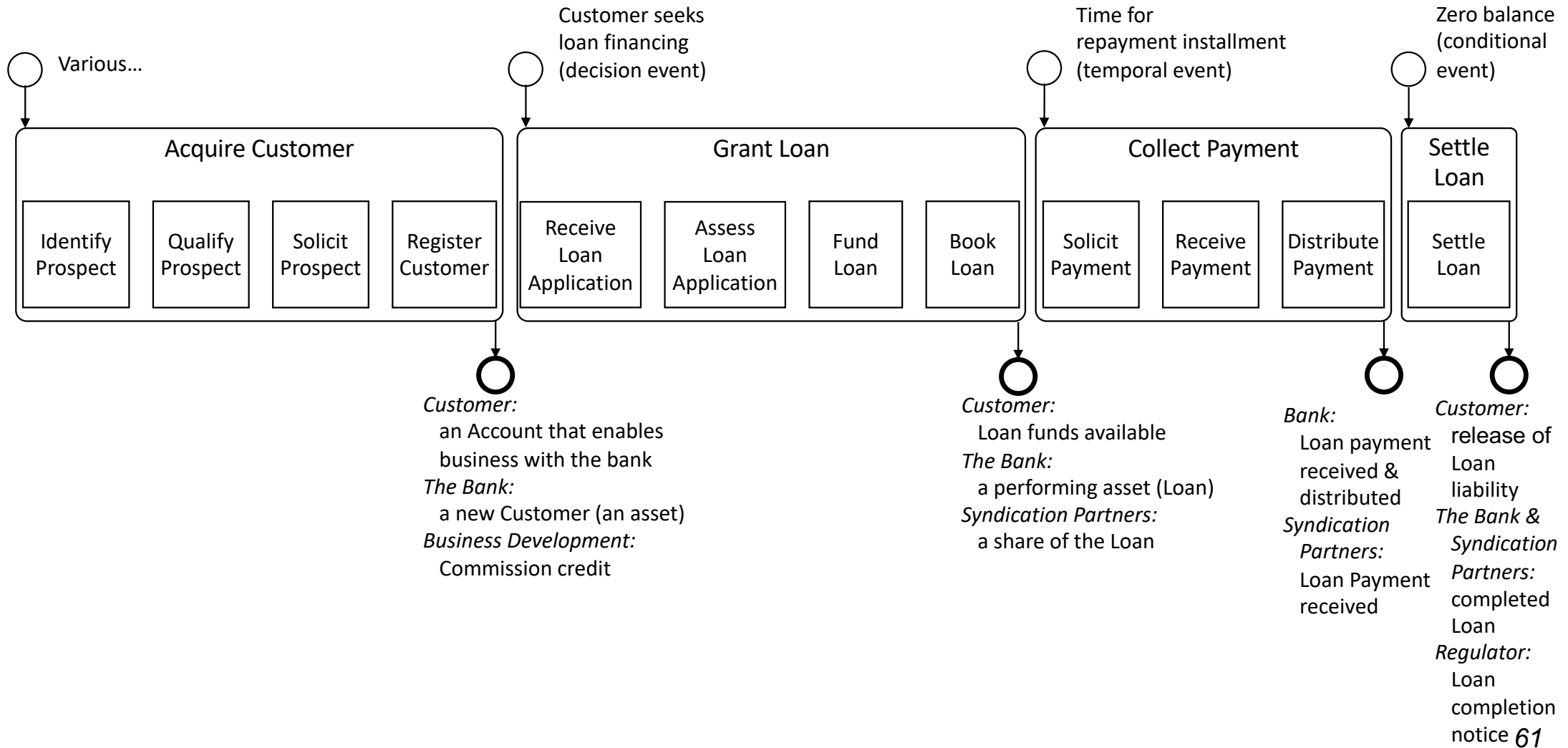

Six guidelines for well-formed processes, two clients really appreciate

1. “Active verb – noun” naming that indicates primary result
2. Triggered by an event (decision, time, data) outside process’ control
3. At the end are results that makes one or more stakeholders happy
4. In between are ~5 to 7 major Activities (phases, milestones, subprocesses, ...)
5. Activities linked 1:1 are probably part of the same process;
a 1:M or M:1 connection between activities is probably a boundary
6. The same *token* moves through the whole process,
changing state, e.g. a Loan, from applied to booked;
there will be a *change of token* across a process boundary

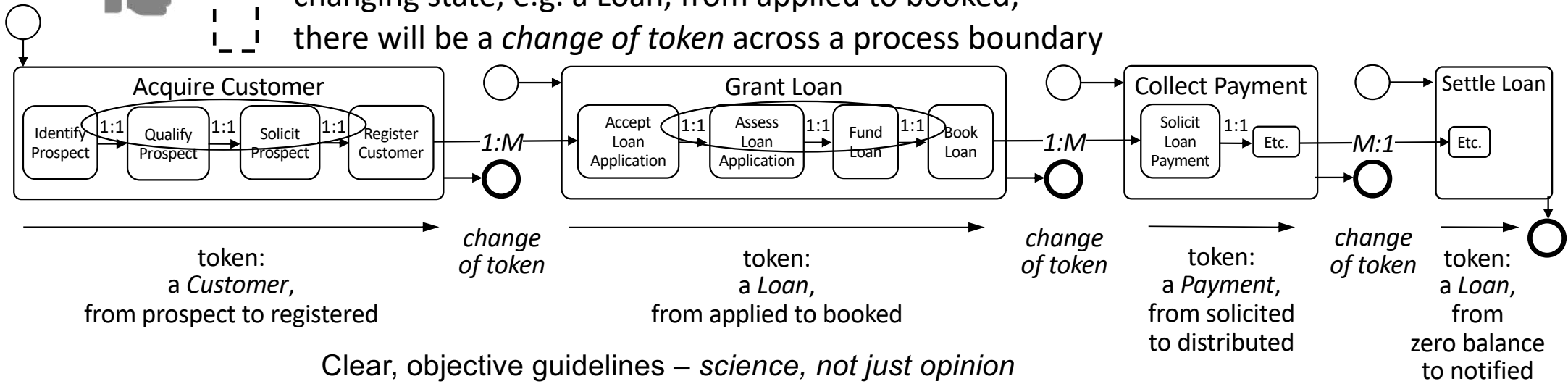

Clear, objective guidelines – *science, not just opinion*
Client had faith these were *their* business processes

Doing this virtually with a tool like Lucidchart...

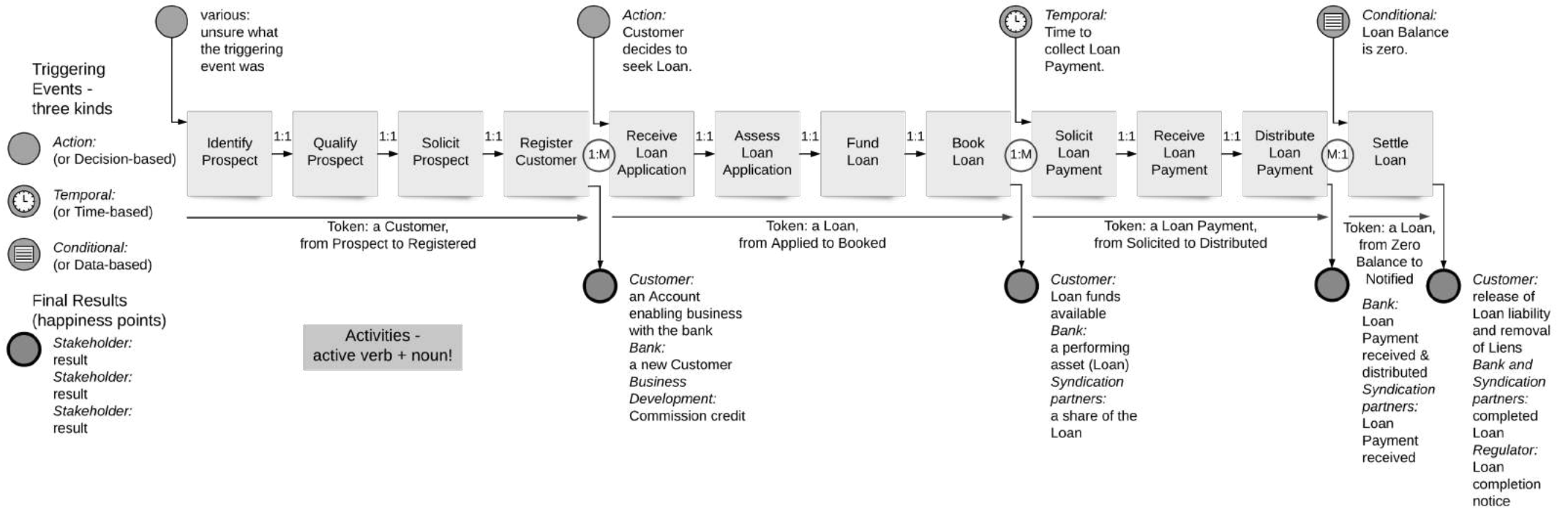

Correspondence to the Concept Model

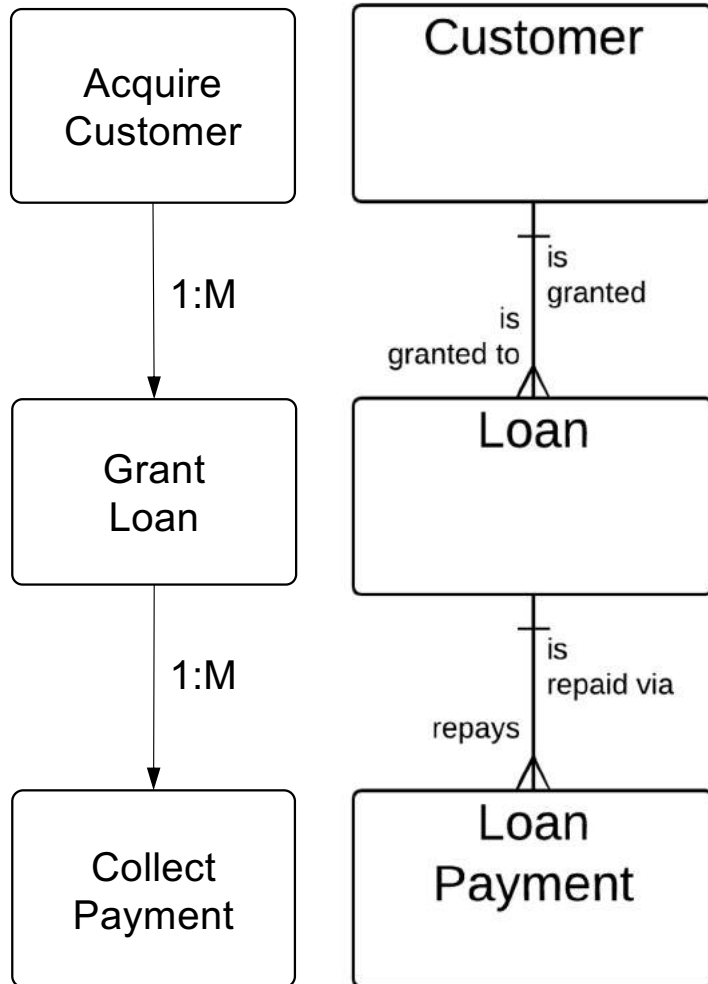

- The nouns in your verb-noun *Process* name are most often the *Entities* in your Concept Model, and each will usually have one primary *Process*
- The relative number of Process instances (e.g., 1:M or M:1) align with relationship cardinality
- This *does not* mean there is only one Process per Entity
 - *Assess Customer Performance*
 - *Retire Customer*
 - *Merge Loans*
 - *Write Off Loan*
 - ...

What next?

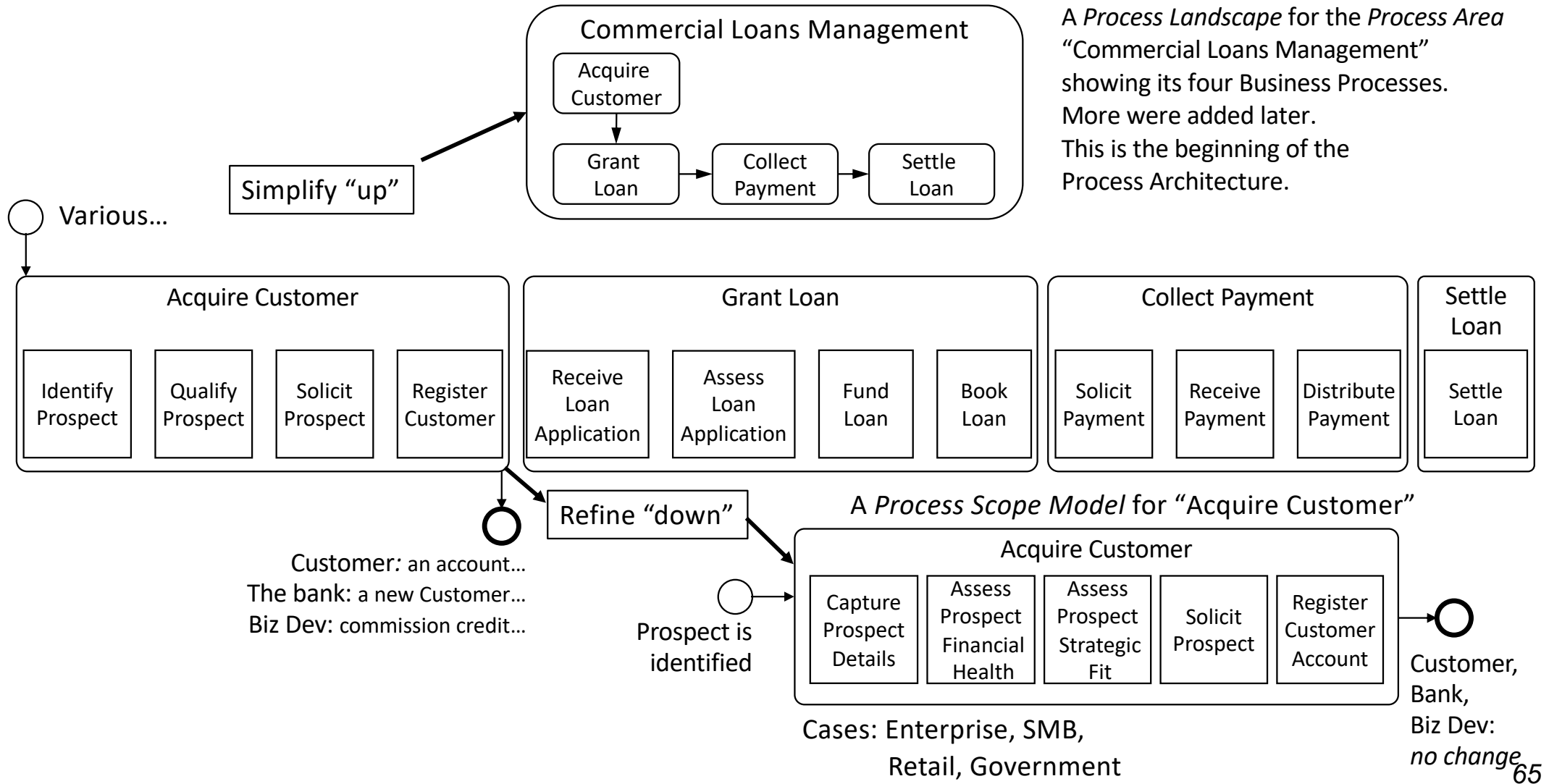

A Process Landscape for the Process Area "Commercial Loans Management" showing its four Business Processes. More were added later. This is the beginning of the Process Architecture.

The arc of modelling and analysis

Start bottom-up to build overall framework – Continue top-down

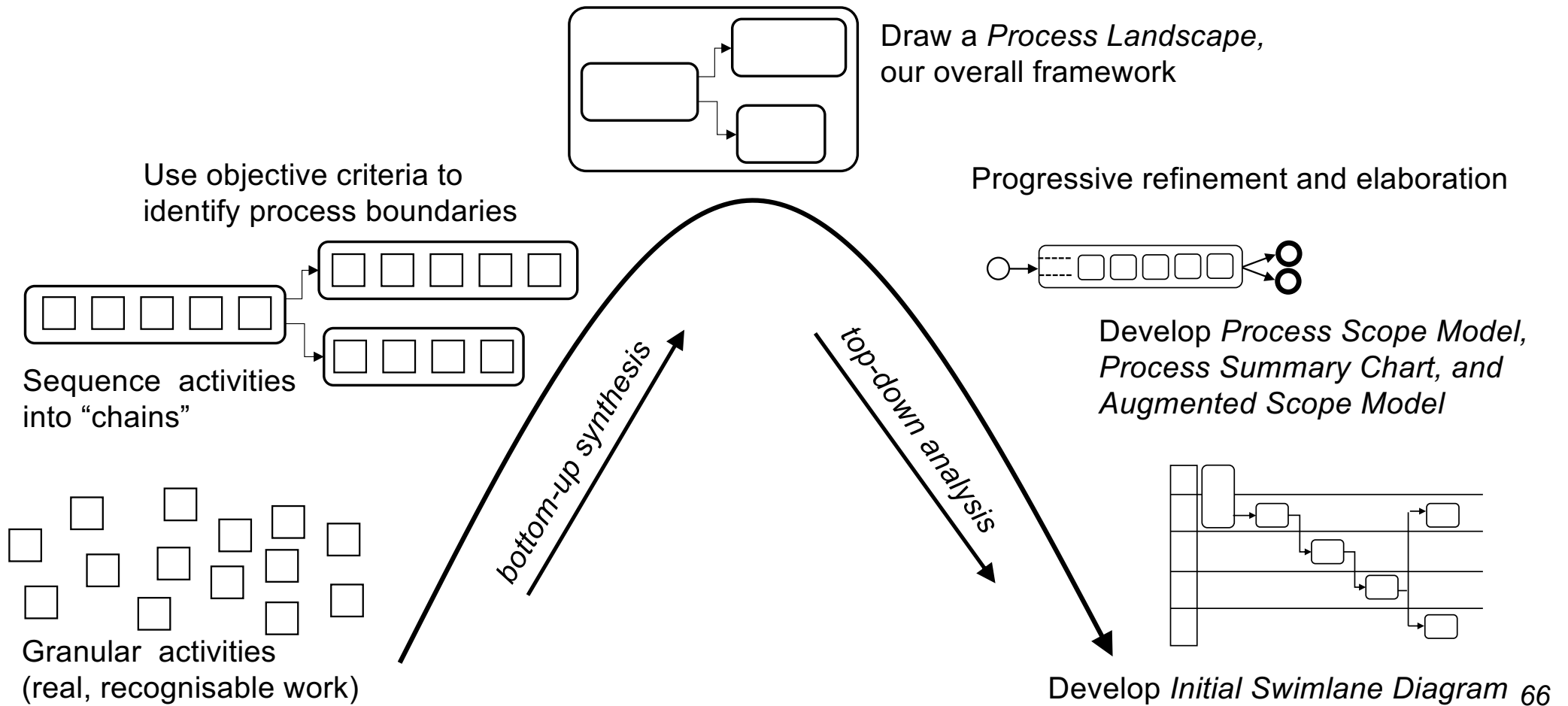

Building a Process Architecture

1. Communicating the fundamentals of *Business Processes*
2. Identifying true, end-to-end, cross-functional *Business Processes*
3. Developing a *Process Architecture*
4. Seven ways to help people embrace *Process Change*
5. *Human-oriented* process modelling
6. A feature-based *Process Design* method –
transitioning from *as-is* to *to-be*

...including a bonus –
material on Concept Modelling!

Case study – Process Architecture on a budget, non-invasively

Client –

- Regulatory agency ensuring the safe design, installation, and use of technical equipment
- Natural gas systems, electrical systems, boilers and pressure vessels, elevating devices, & many more



Goal –

- Use leftover budget at year-end to develop an Enterprise Process Architecture

Agreement –

- We will experiment with novel approaches if we can use it as a case study
- Non-invasive – minimal interviews, no sessions
- Use available resources – existing models and *anything else we could find*
- Two experienced Business Process Analysts made available part-time

Many approaches to process discovery

Top-down discovery is often less effective than expected, yielding a view that is functional, organisational, or fragmented

Bottom-up discovery is often more effective at the **project level** – identify relevant lower level activities, link to form complete processes

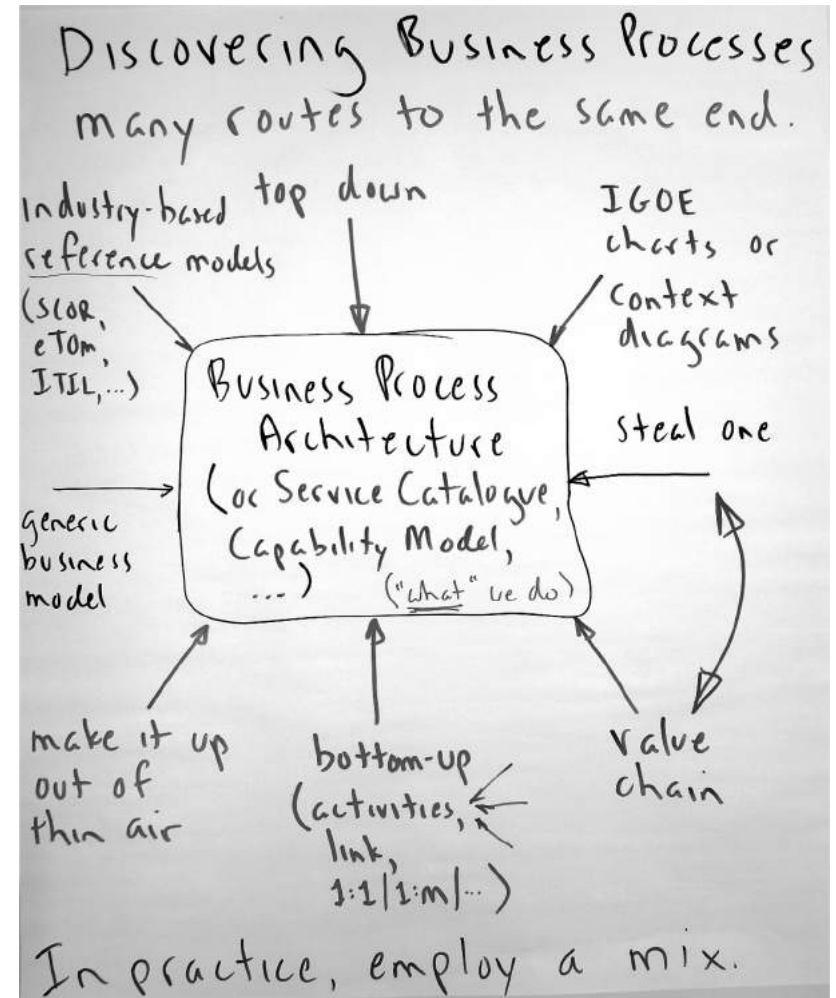

Discovering processes at enterprise scale

Bottom-up techniques alone are impractical for the enterprise

“Classic” approach:

- Large project, core team of 5+ people, scores of interviews and sessions with many participants, over many months or even years
- “Boil the ocean” – expensive and time-consuming

Alternate approach (Regulatory Agency case study)

- Build first-cut (better than “draft”) process architecture
- Small team, limited number of interviews and sessions
- Use available knowledge, e.g., Business Analysts
- Use other available resources, e.g., typical patterns and frameworks, organisation's training materials, job/role descriptions, reference models, industry texts, ...
- Refine architecture over time, process by process

Business Process Categories – highest level of Process Architecture

These processes provide guidance to the enterprise on its mission, strategies, goals, and objectives, and coordinate interaction with external agencies and regulators. Also called *Directional* or *Steering* processes.

**Governance &
External Relations
Processes**

These processes deliver results that are the essence of why the enterprise exists – they are unique to a particular line of business and provide results that are visible to external stakeholders.

***Line of Business (LoB)
Processes
(within scope)***

These processes deliver resources – people, facilities, systems, etc. – and services – accounting, risk mitigation, procurement, etc. – which enable the LoB processes to operate.

***Supporting
Processes
(within scope)***

Sensitivities about naming

***Line of Business
~~Core~~
Processes***

***Supporting
~~Non-core?~~
Processes***

***Supporting
~~Enabling~~
Processes***

A look ahead – Business Process Architecture taxonomy

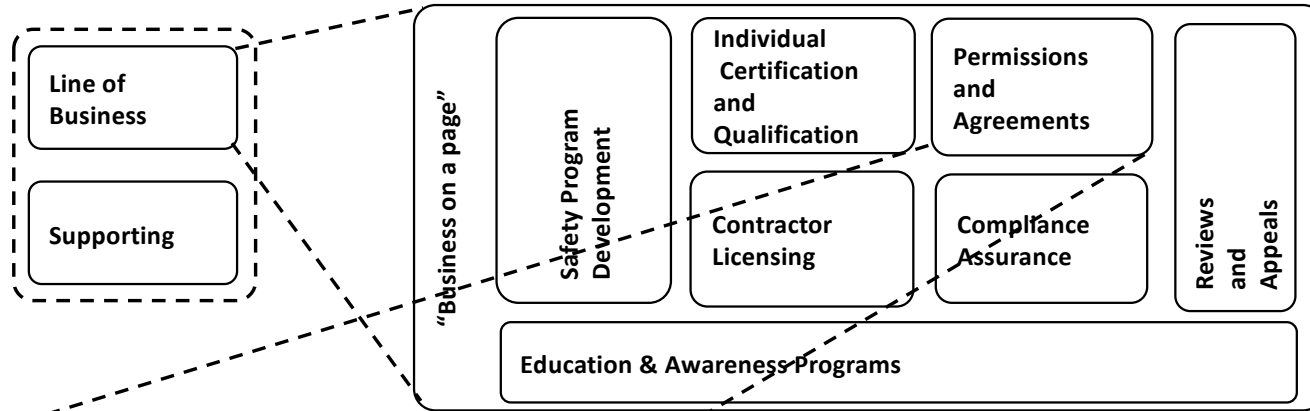

7 "Process Areas" or "Process Domains" – level 0

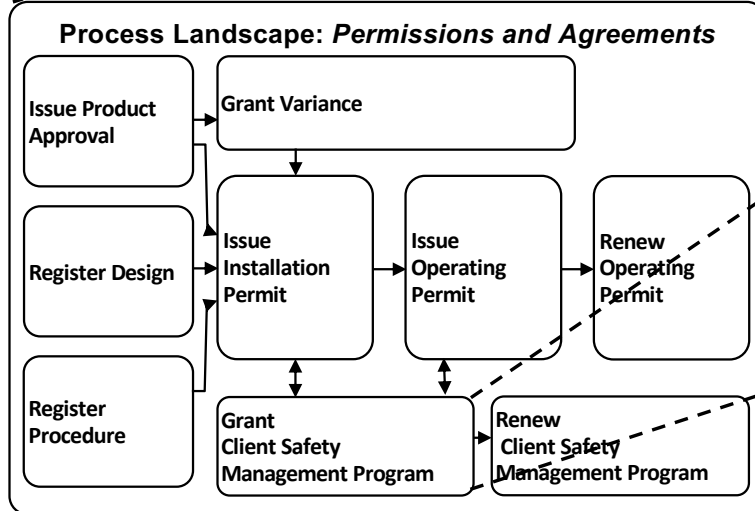

9 "End-to-end Business Processes" – level 1

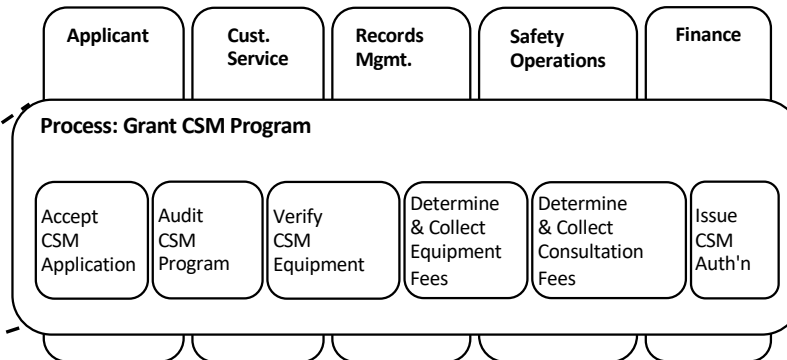

1 Business Process with 5 +/- 2 sub processes (level 2)

Additional detail about each business process is added during "framing"

How to start – reference models?

Useful for... *reference!*

Not really “business processes,”
in our terms:

Functional orientation

Catalogues of *activities*

Extremely inconsistent *granularity*

8.0 Manage Financial Resources (10009)

8.4 Manage fixed asset project accounting (10731)

- 8.4.1 Perform capital planning and project approval (10751)
 - 8.4.1.1 Develop capital investment policies and procedures (10844)
 - 8.4.1.2 Develop and approve capital expenditure plans and budgets (10845)
 - 8.4.1.3 Review and approve capital projects and fixed asset acquisitions (10846)
 - 8.4.1.4 Conduct financial justification for project approval (10847)
- 8.4.2 Perform capital project accounting (10752)
 - 8.4.2.1 Create project account codes (10848)
 - 8.4.2.2 Record project-related transactions (10849)
 - 8.4.2.3 Monitor and track capital projects and budget spending (10850)
 - 8.4.2.4 Close/capitalize projects (10851)
 - 8.4.2.5 Measure financial returns on completed capital projects (10852)

8.5 Process payroll (10732)

- 8.5.1 Report time (10753)
 - 8.5.1.1 Establish policies and procedures (10853)
 - 8.5.1.2 Collect and record employee time worked (10854)
 - 8.5.1.3 Analyze and report paid and unpaid leave (10855)
 - 8.5.1.4 Monitor regular, overtime, and other hours (10856)
 - 8.5.1.5 Analyze and report employee utilization (10857)
 - 8.5.2 Manage pay (10754)
 - 8.5.2.1 Enter employee time worked into payroll system (10858)
 - 8.5.2.2 Maintain and administer employee earnings information (10859)
- Etc. etc. etc.

How to start – Michael Porter's “Value Chain?”

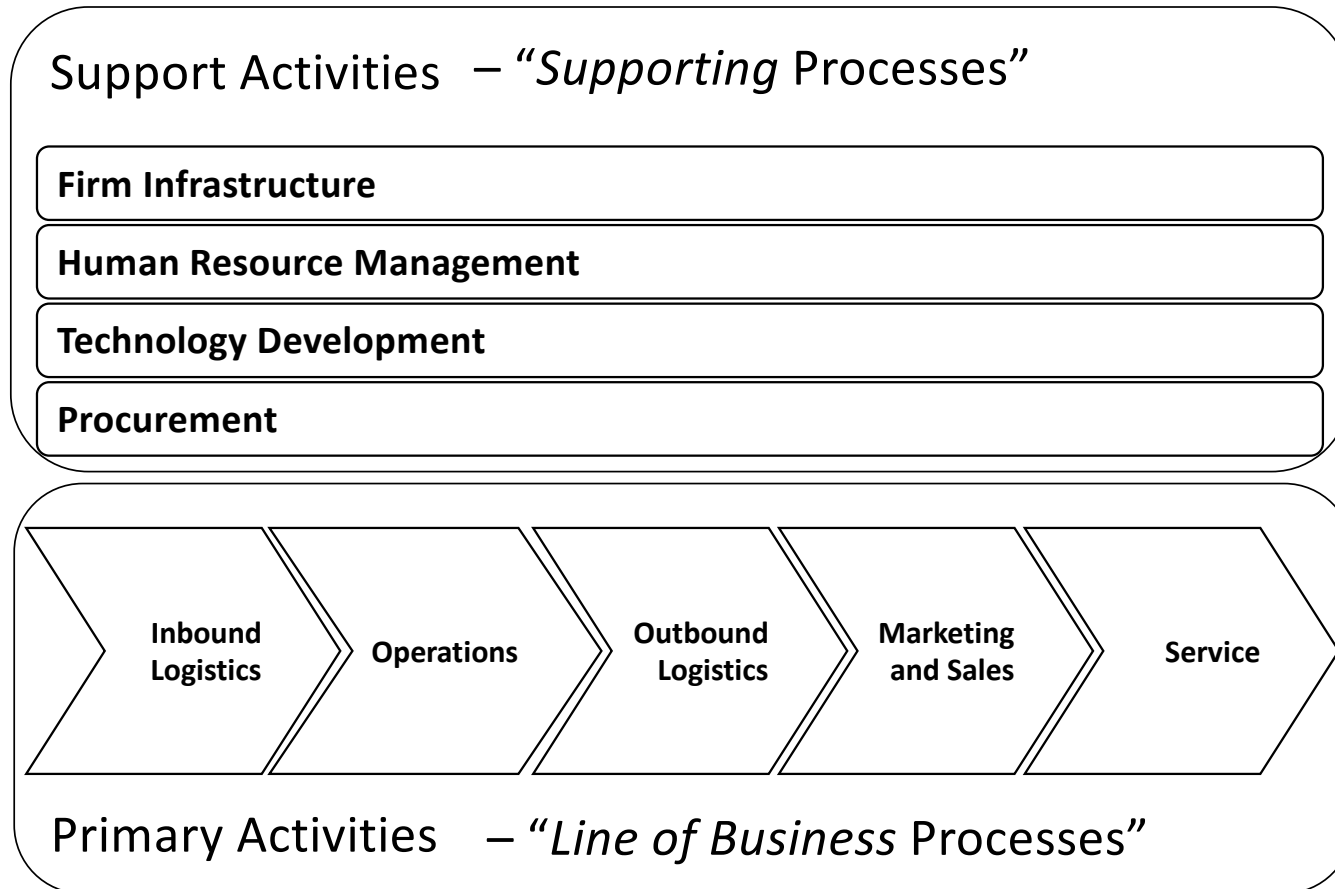

Sometimes it works, sometimes not.

We tried using Value Chain for first cut



“JDFR” – Just Didn't Feel Right

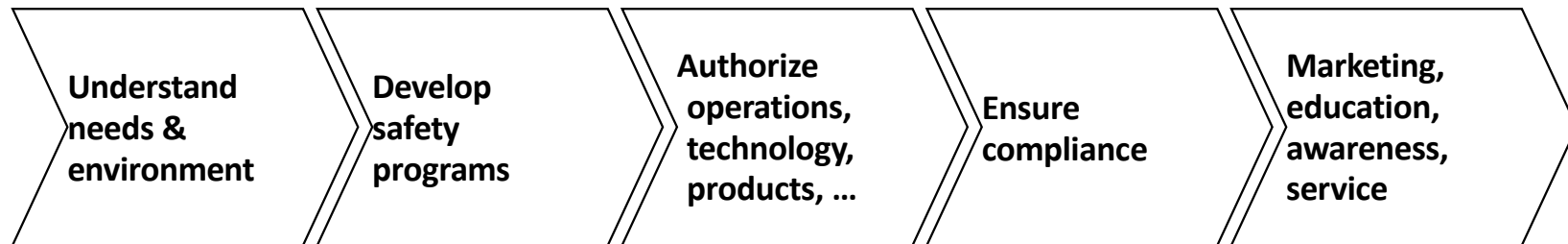

“CBNC” – Close, But No Cigar

How to start – a generic business model?

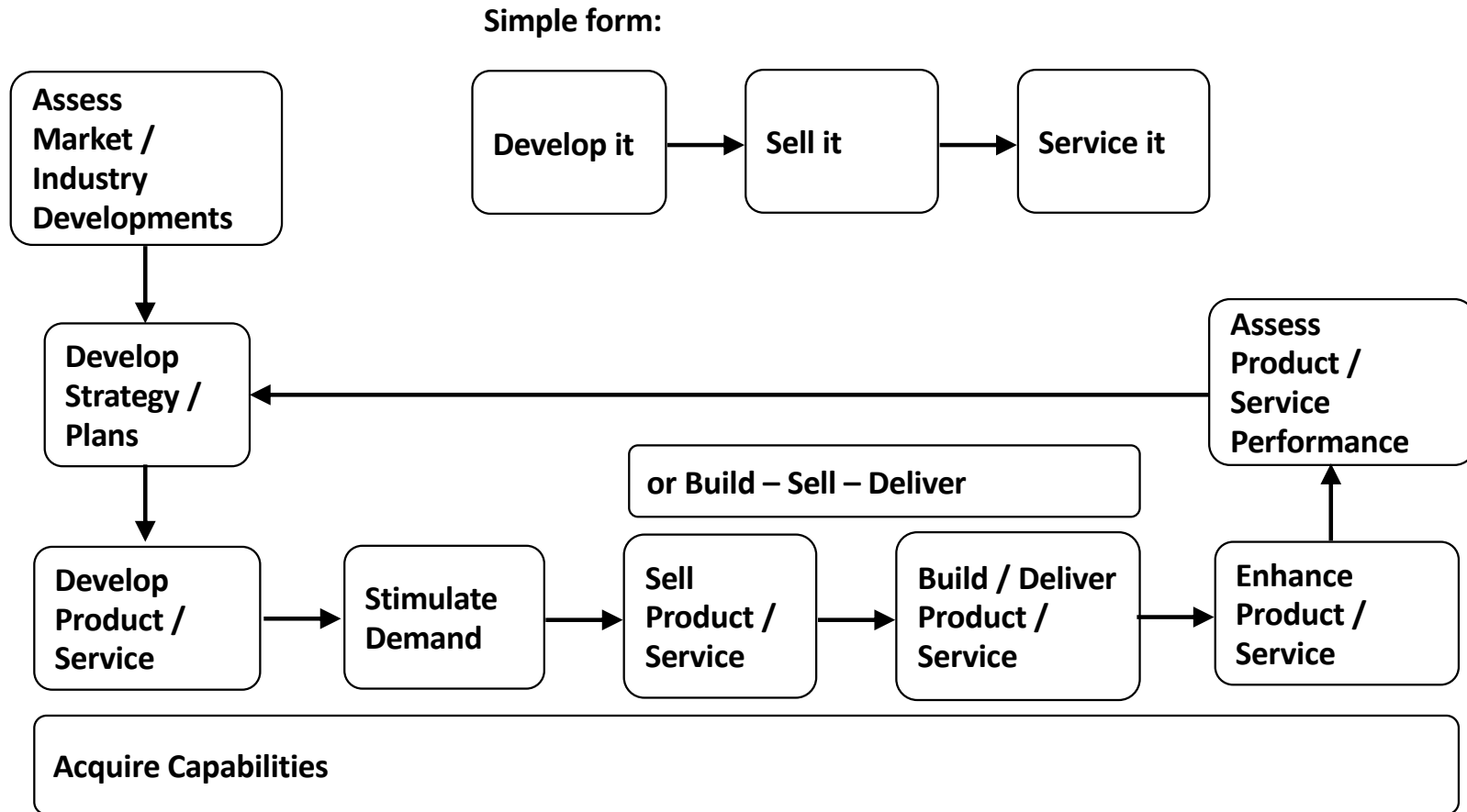

Generic models worked – first-cut list of process areas

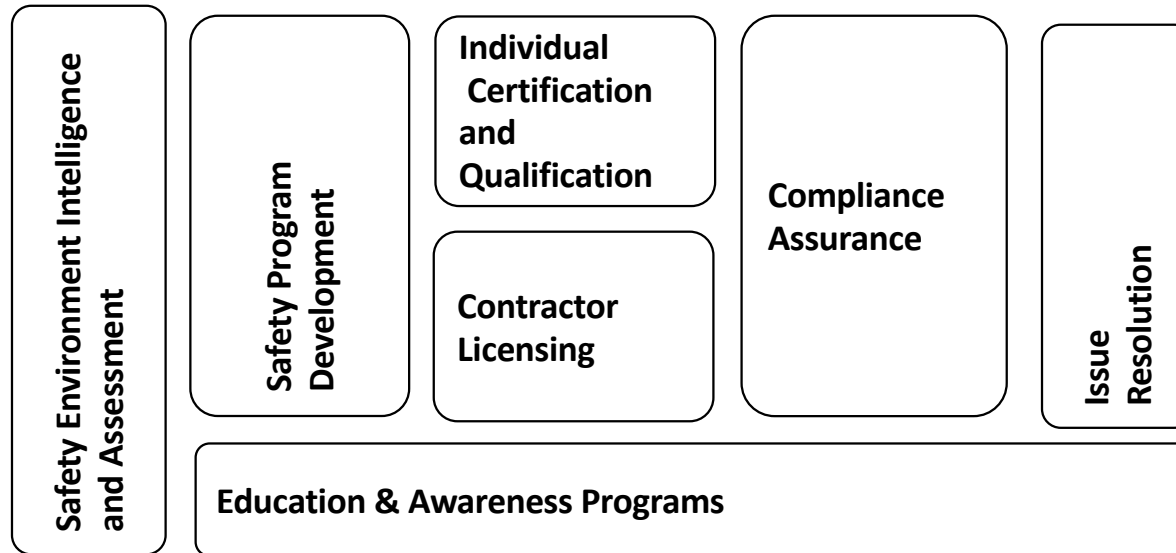

Not bad, but:

- Political issues (“Where's MY group...?”)
- Refined through bottom-up work

Generic model for asset management processes

Asset Management Life Cycle:

Starting point for supporting processes, shared resources:

People, Facilities, Fleet, Technology Assets, ...

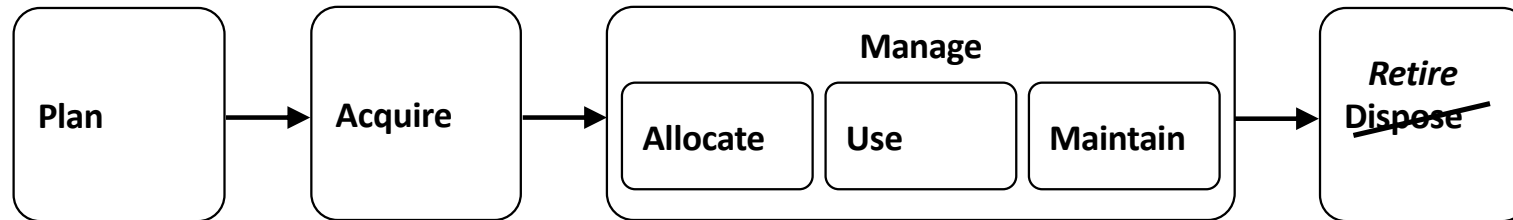

Supporting began with the usual suspects, which didn't last:



However, the Asset Management Life Cycle was a good starting point for each.

Service maps – a lucky find

For a school project, BAs had catalogued the services provided by each functional area.

We refined them, then validated them with functional experts – *it was easy!*

Discussion – why did this layout work?

Services ranged from discrete activities to near-business processes.

Services (activities) could be strung together into plausible business processes.

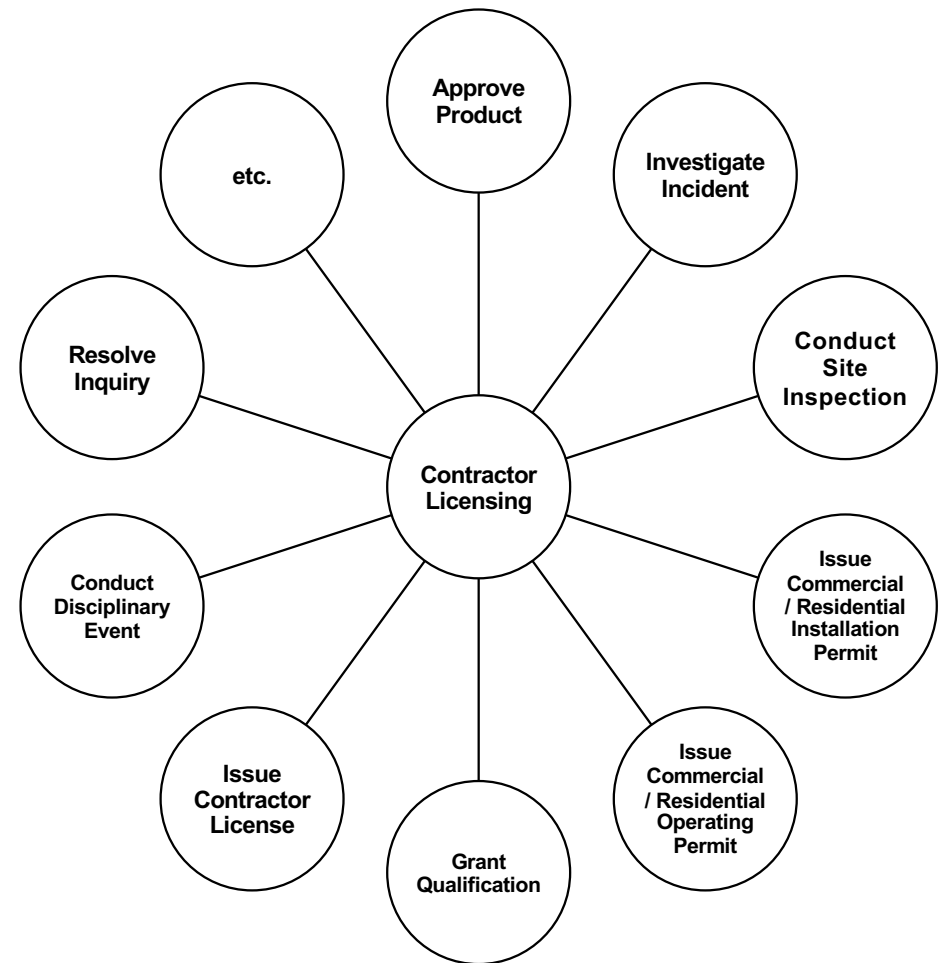

Another lucky find – role profiles

Department: *“Market Awareness”*

Position Title: *Communications Officer*

Principal Accountabilities:

...

Key Messaging: develop corporate key messages and issues messages aligned to the Strategic Plan to ensure that Agency staff, Executive and Board consistently utilize strategic messaging in all internal and external documents and ensure marketing and branding initiatives align with strategic communications goals and messages.

Communications: ...description of more responsibilities

Media Messaging: ...description of more responsibilities

...

*Observation –
the further from core operational responsibilities, the
harder to decipher...*

A lot of work to massage into discrete activities

“...in partnership with internal and external stakeholders, using the full range of traditional and new media along with an integrative framework, disseminates relevant content that will enable self-sufficiency among business and residential constituencies.”

Translation: “*Publish procedures.*”

	Department	Position Title	Activity	Process Area	Process
152	Corporate Services	Assets & Supplies Coordinator	Arrange office renovation	Procure	“Configure” facility
124	Corporate Services	Leader, Facilities & Fleet	Negotiate accommodation lease (new and renewal)	Procure	Acquire Facility
125	Corporate Services	Leader, Facilities & Fleet	Identify office location	Procure	Acquire Facility
126	Corporate Services	Leader, Facilities & Fleet	Develop office space plan	Procure	Acquire Facility
127	Corporate Services	Leader, Facilities & Fleet	Arrange office move	Procure	Acquire Facility
128	Corporate Services	Leader, Facilities & Fleet	Arrange office reconfiguration	Procure	Acquire Facility
138	Corporate Services	Facilities Coordinator	Complete office move (coordinate w. project managers, designers and planners)	Procure	Acquire Facility
145	Corporate Services	Assets & Supplies Coordinator	Issue/revise/terminate security access	Procure	Acquire Facility
121	Corporate Services	Leader, Facilities & Fleet	Identify operational needs	Procure	Acquire Vehicle
129	Corporate Services	Leader, Facilities & Fleet	Acquire property management service (maintenance and security)	Procure	Maint/Repair Facility
130	Corporate Services	Facilities Coordinator	Provide space planning advice	Procure	Configure Facility
118	Corporate Services	Leader, Facilities & Fleet	Develop facilities strategic plan	Procure	Facilities planning
119	Corporate Services	Leader, Facilities & Fleet	Develop accommodation strategic plan	Procure	Facilities planning
23	Finance	Leader, Performance Reporting	Determine replacement schedule of vehicle fleet.	Procure	Fleet planning
120	Corporate Services	Leader, Facilities & Fleet	Develop fleet strategic plan	Procure	Fleet planning
153	Corporate Services	Assets & Supplies Coordinator	“Liaise” with building maintenance	Procure	Maint/Repair Facility
401	Legal & Policy	Legal Counsel	Retain external counsel	Procure	Obtain service

“Assemble” business processes

Processes discovery – a “meet in the middle” approach

- Services (from the Service Maps) and Activities (from the “massaged” Role Profiles) were grouped into first-cut Process Areas (all treated simply as “activities”)
- Some activities (services) appeared in multiple processes
- Link activities as described earlier
- Analyse connections (1:1, 1:M, ...)
- Identify and name Business Processes
- Adjust high-level Process Architecture (the Process Areas)

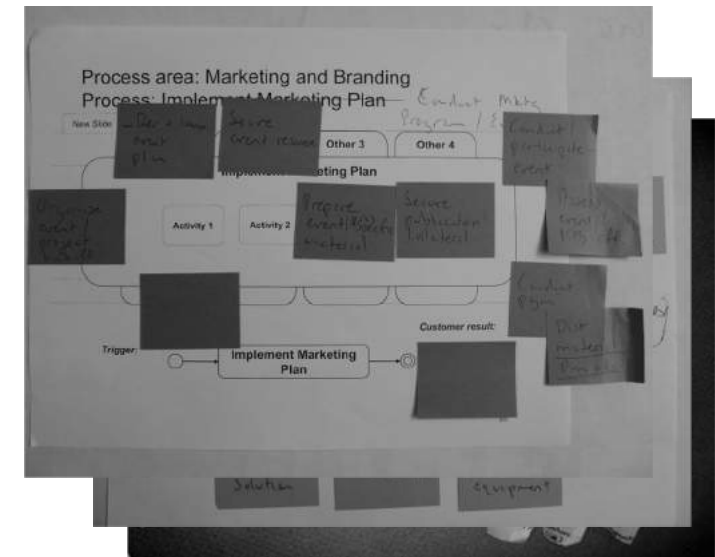

“Final” LOB Process Areas (or “Families” or “Domains”)

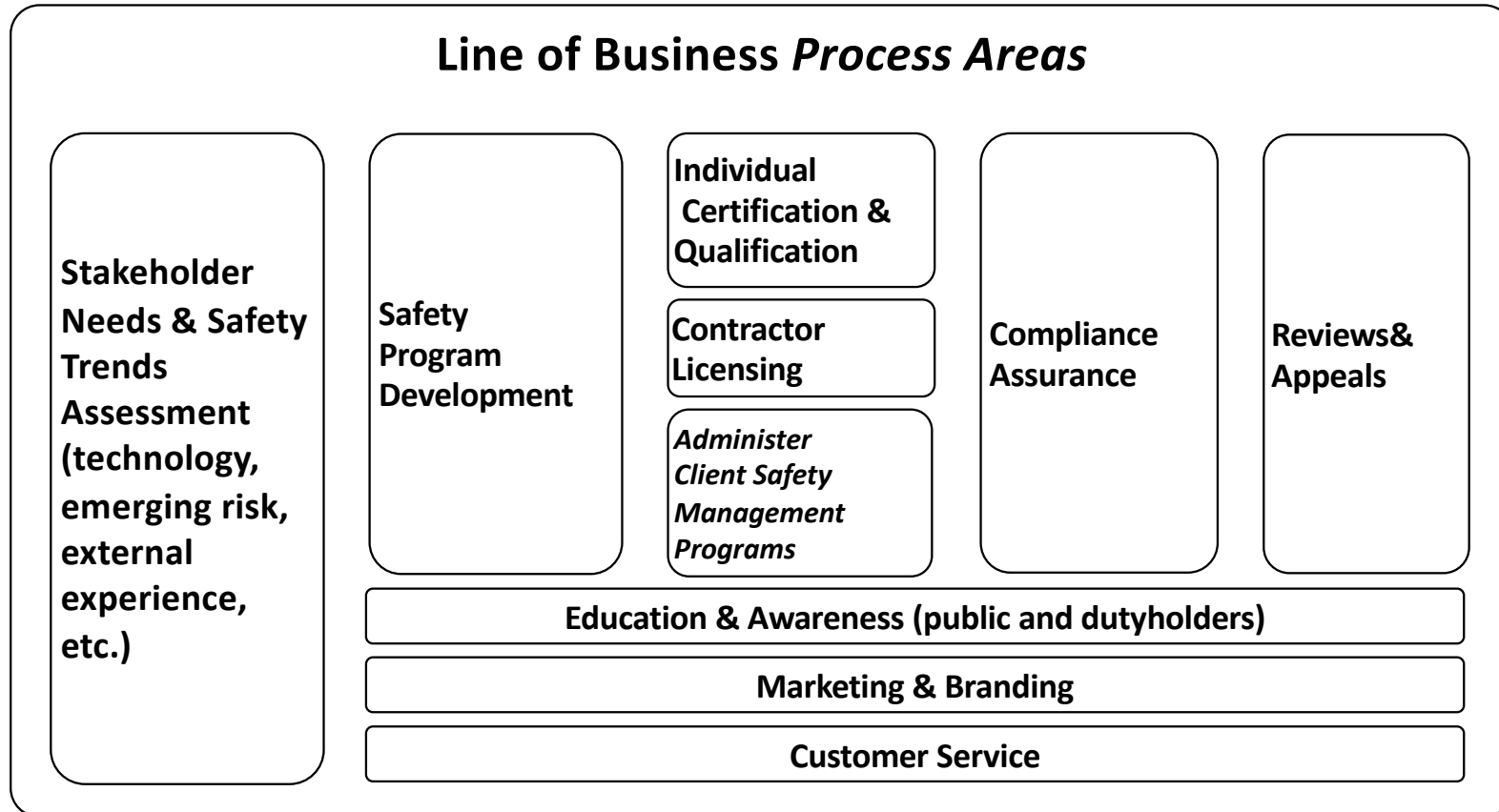

We progressively refined process scope starting with "what"

- 1) We depict the *scope and contents* of each **Process Area** with a **Process Landscape** – a decomposition of the **Process Area** into individual **Business Processes**
- 2) Next illustrate the *scope* of a single **Business Process** with a **Process Scope Model** – a pure statement of “what” in terms of Trigger, Results, major Activities, and Cases (**TRAC**)

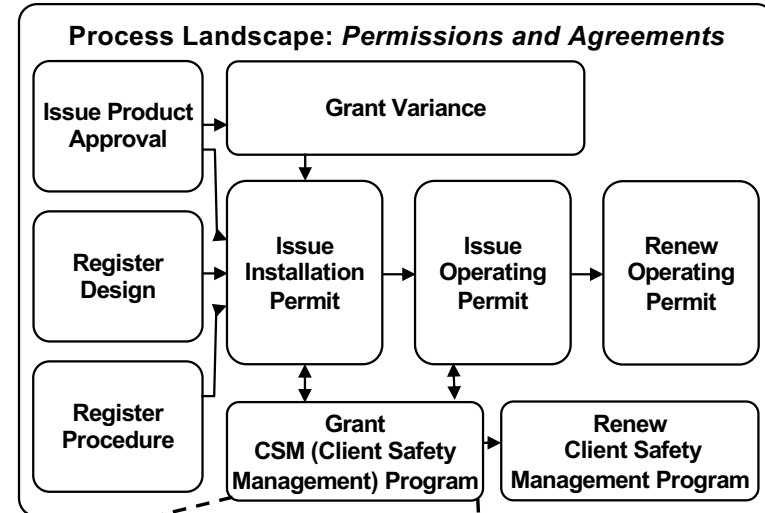

Trigger:
Client submits request to enter into a CSMP

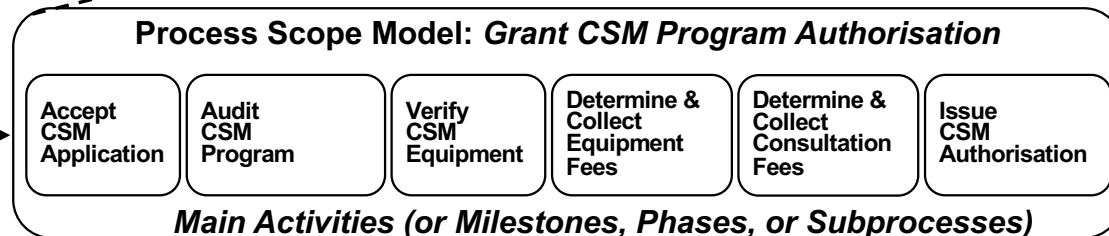
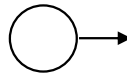

- Cases:**
- New
 - Grandfathered
 - Ownership Change

Client Result:
Approval granted for a self-managed safety program.

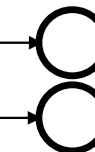

Agency Result:
Revenue collected. New participant in CSMP; confirmation that regulations are satisfied

Always establish “what” (TRAC) first!

Now develop the Process Summary Chart

Trigger:
Client submits
request to
enter
a CSMP

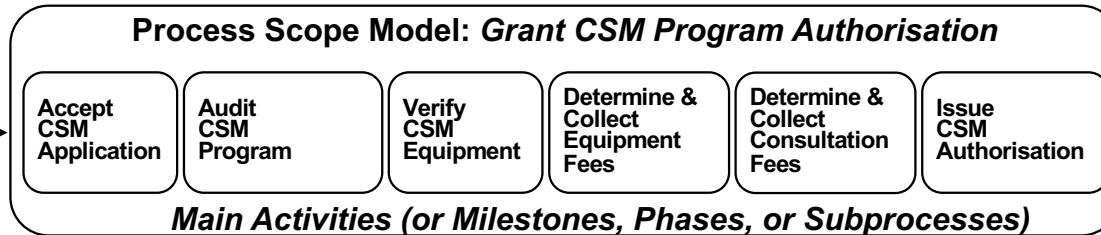

Client Result:
Approval granted for
a self-managed
safety program.

Agency Result:
Revenue collected.
New participant in
CSMP; confirmation
that regulations are
satisfied

- Cases:**
- New
 - Legacied
 - Ownership Change

Process Scope Model – pure “what”...



Process Summary Chart – simplified “what,” plus “who”

A powerful communication tool!

“Final” Supporting Process Areas

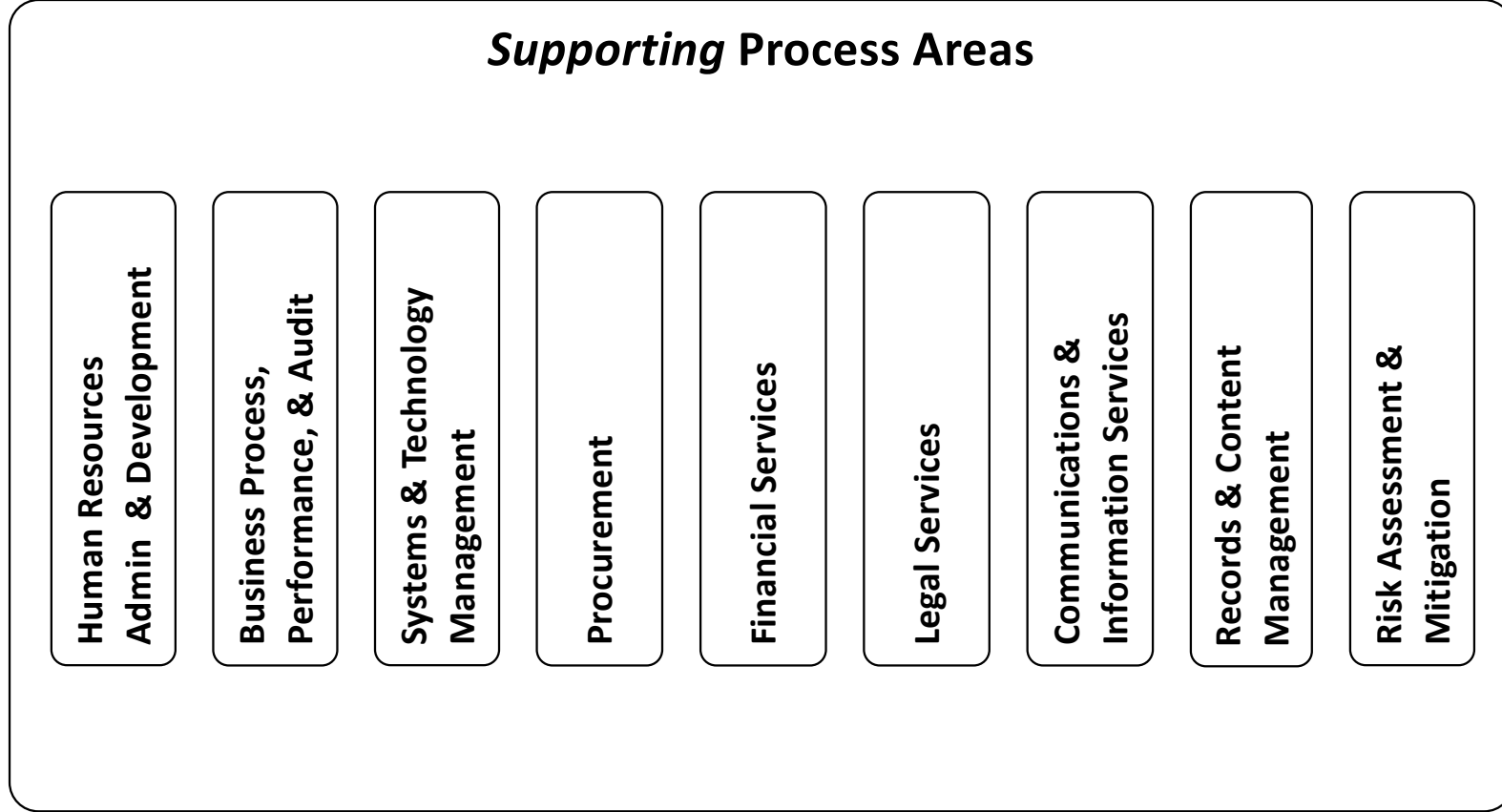

Processes within one Supporting Process Area

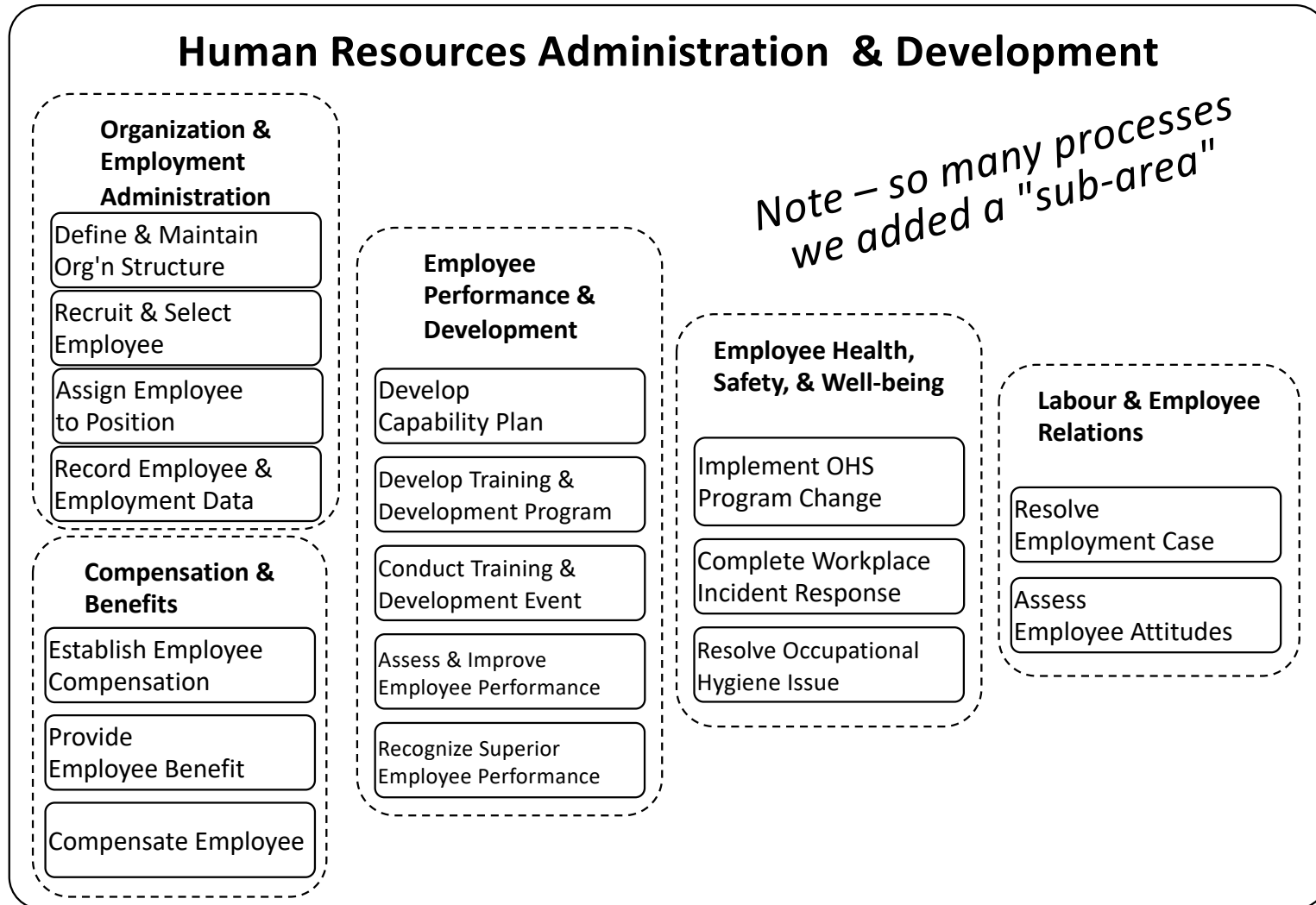

Scoping one Supporting Business Process

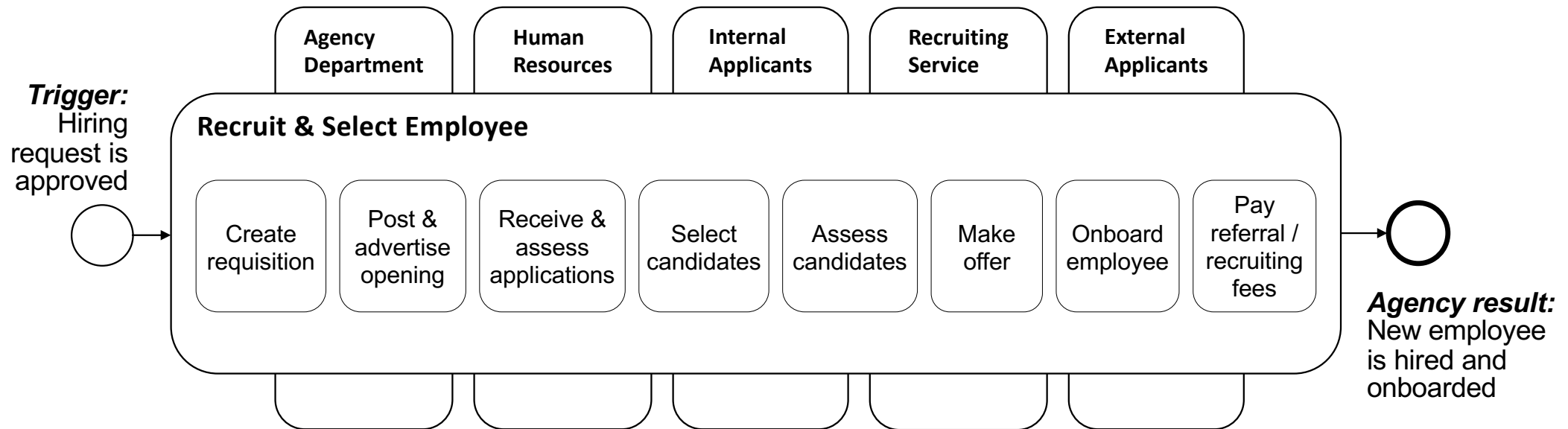

Obligatory “Everything on one page” graphic

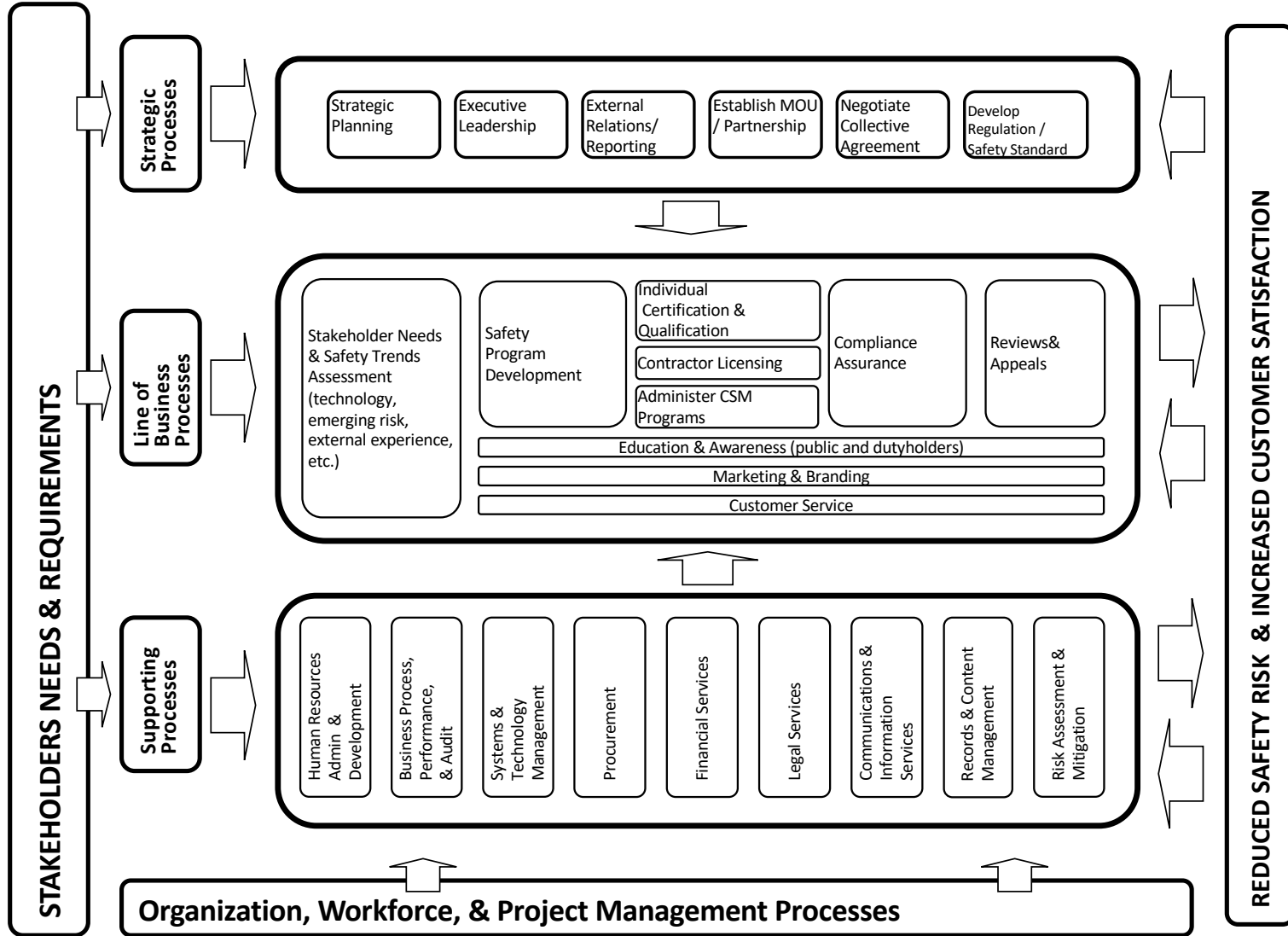

Notes and numbers

The numbers:

- 2 Categories: Line of Business and Supporting
- 27 Process Areas
- 103 End-to-End Business Processes
- ~600 Subprocesses

Observations:

- Line of Business processes highly cross-functional, much to everyone's surprise
- Supporting *functions* often had significant involvement in Line of Business Processes, esp. Financial Services
- Supporting processes:
 - More numerous and “smaller” – quick transactions
 - Less cross-functional

Note – the C-level executives' comments were amazing!

On the other hand...

Experienced people who know the business can iterate quickly to a plausible, high-level architecture

This “Business on a Page” work at a pipeline operator was completed in half a day

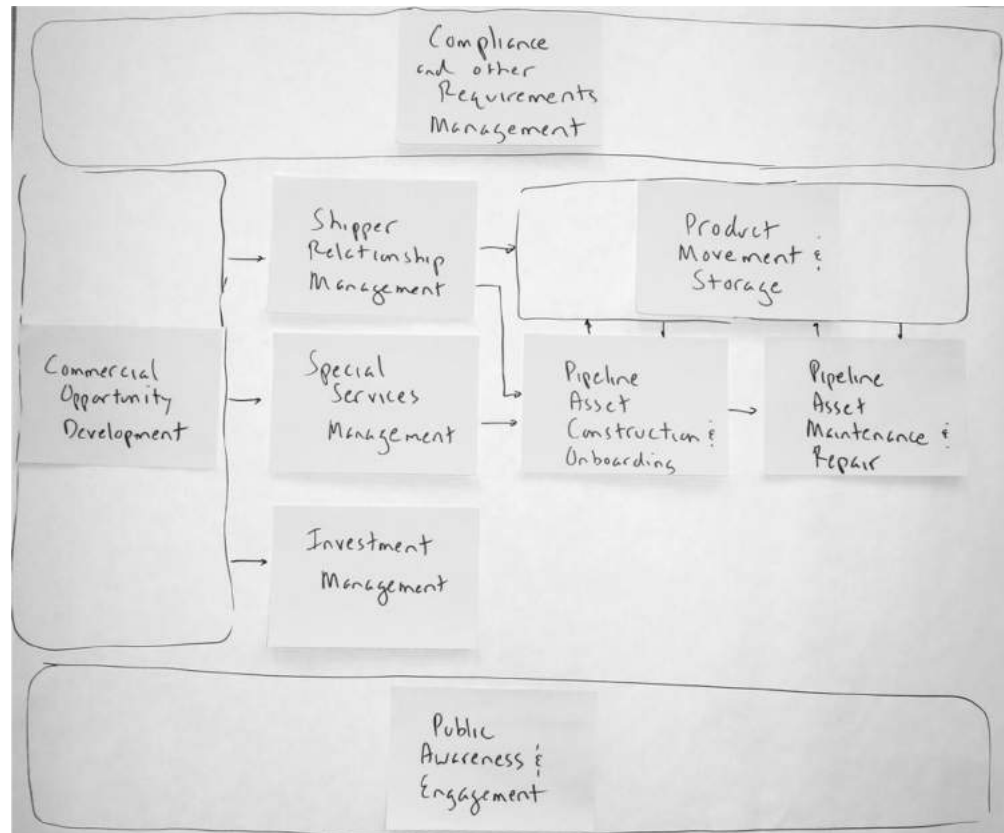

On the other hand – cleaner version

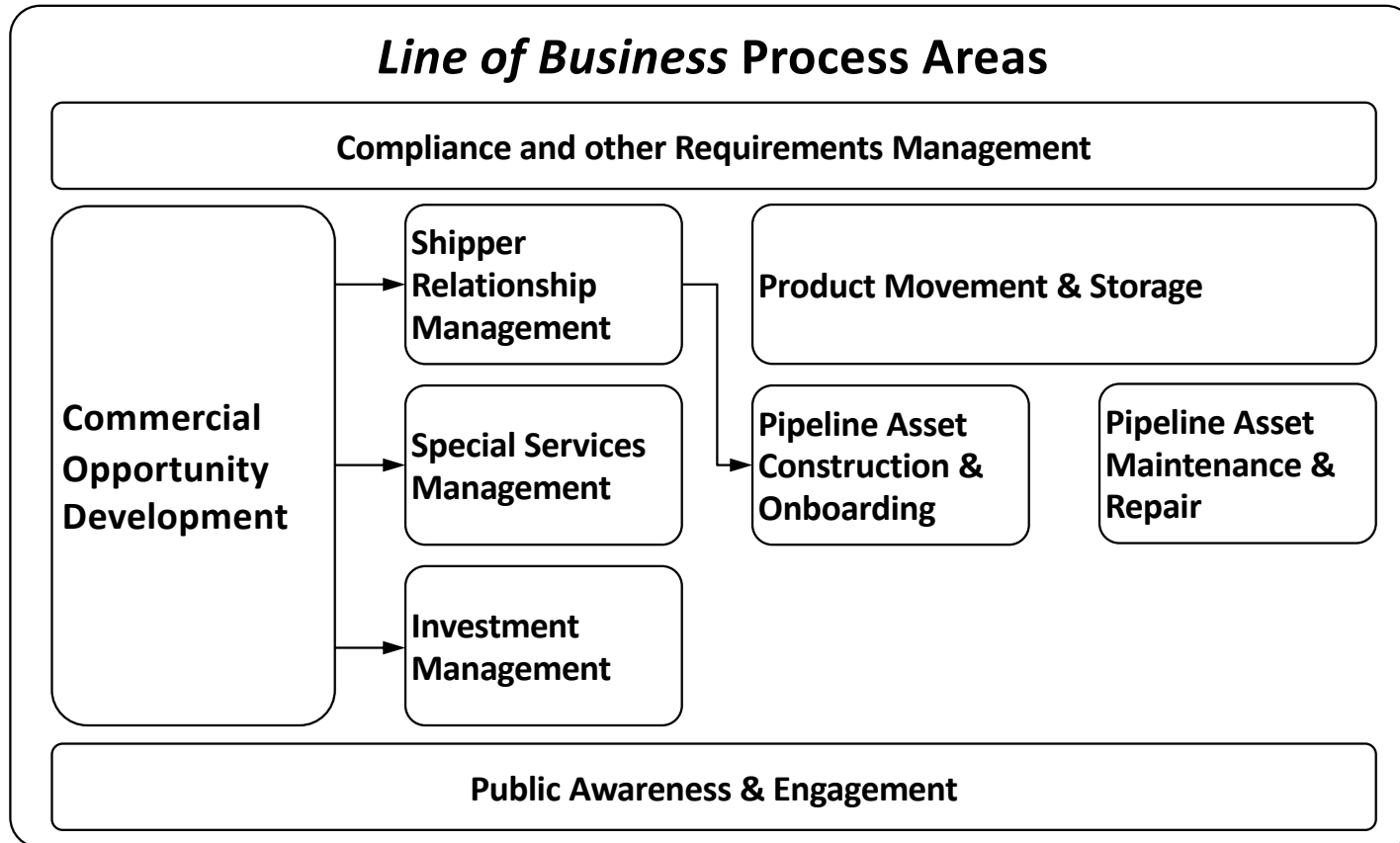

Case study – using the architecture

Soon after completing the architecture, an opportunity arose to put the process architecture to work

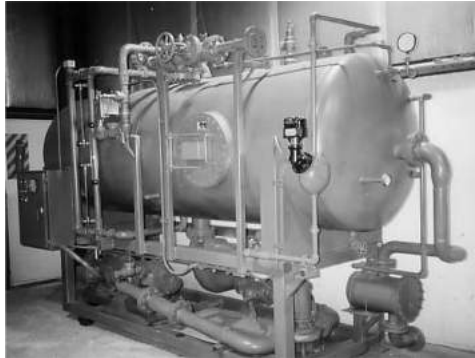

Opportunity in
“Boilers & Pressure Vessels”

Goal –

- Shift from an inspection-based model (~800 inspectors!) to client-managed safety programs
- Clients will apply for a *Client Safety Management Program Authorisation (CSMP Authorisation)* - must show effective processes and accurate record-keeping
- Clients will pay a fee for managing *their own safety programs!* Still beneficial!



Returning to the case study – Concept Model, Services, Use Cases

- *Business Development chooses Pilot Program – boilers and pressure vessels in Oil & Gas fields*

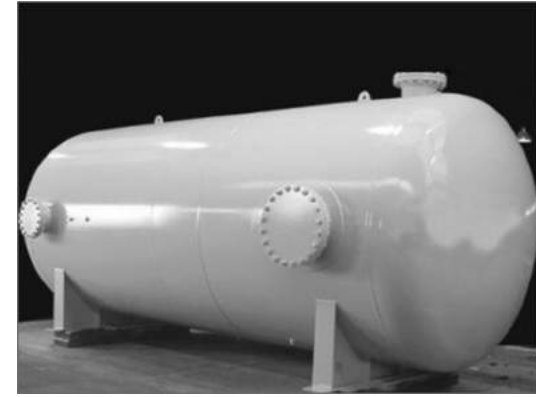
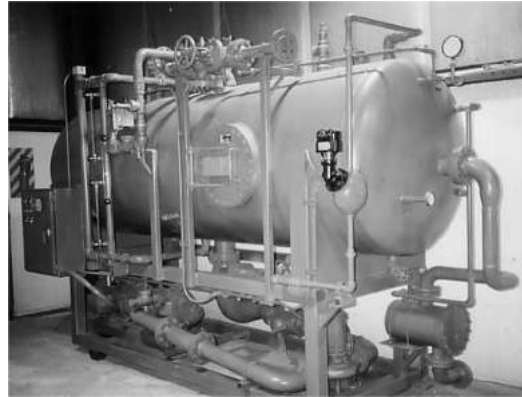

- Current systems won't support CSMP, time-consuming and expensive to change them – IT and Finance suggest 18 – 24 months of work
- BD is unimpressed by IT and Finance objections (“You're being mindlessly obstructionist!”) and proposes work-around procedure. *Guess which tool they intend to use?*
- I'm hired to identify end-to-end implications – “Design a process and determine IT requirements that will allow this procedure to work.”
- *Concept Modelling was a critical tool in understanding the underlying policies, and developing the process & requirements*

First, check the Process Architecture!

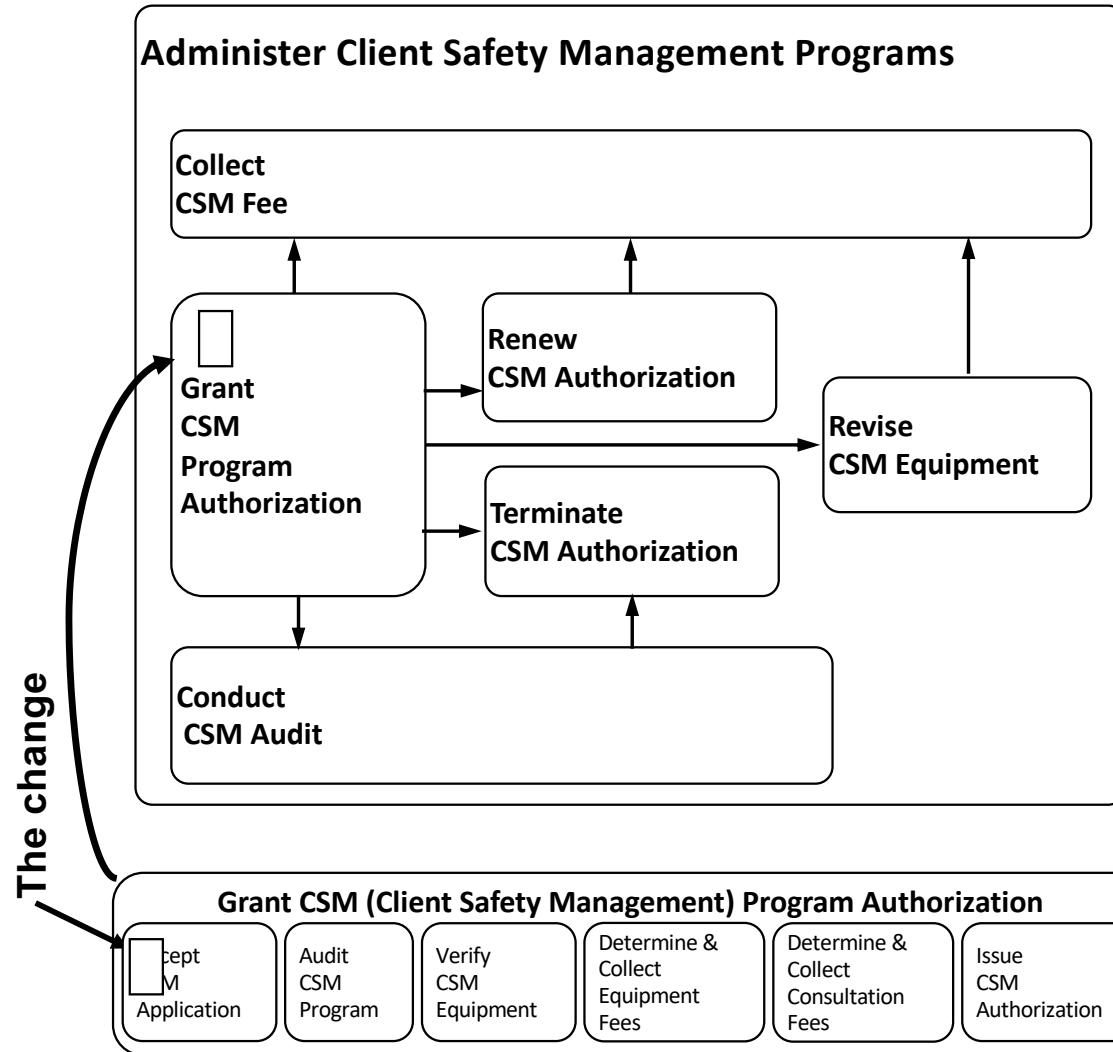

*Immediately checked Enterprise Process Architecture to understand impact areas – **every process except one!!!***

The “simple” workaround would have major impact.

Interviewed functional reps.

A few of MANY issues/assumptions by enabler

Process / Workflow	Manual billing by Finance for all CSMP Units is viable due to low year 1 numbers Will the spreadsheet be validated in the field, or by a Head Office CSR? Will the spreadsheet specifically identify additions/deletions, or just total Units?
Information Systems & Technology	S-MAN doesn't recognize the CSMP concept. Somehow, S-MAN will have to be persuaded to stop invoicing and stop certificate production for CSMP Units
Motivation & Measurement	Regulator will ultimately measure success by CSMP uptake/retention, steady or improved safety records, additional registration revenue, etc. Client savings can be measured through minimized operational disruption
Human Resources	Officers who have expertise at inspecting Units will require major retraining in auditing safety programs If more spreadsheet work by CSRs is expected there will be resource issues.
Policies & Rules	What is the scope of a CSMP - a client? a facility/site? Is it legal to issue a single Bulk Operating Permit for all CSMP Units? How will we handle Units that have been operating outside of conformance?
Financial	Is there agreement on the idea of a flat rate per-unit fee for CSMP Units? If not, what alternatives have been developed? Size, type, negotiation, ...? An application fee will be charged. Will there be a consultation fee?

Concept Modelling was a critical tool in this initiative – let's have a closer look at it...

An interlude on Concept Modelling

- Concept Modelling / Data Modelling is *crucial* to Business Process work
- The “things” you define in your data model are the things that
 - processes act on
(in verb-noun process naming, the noun is a “thing” – an entity)
 - businesses want information about
 - applications revolve around
- Businesses need a *common language* more than ever

Note – it often works best if you don't begin with a lecture on *Concept Modelling* or *Data Modelling*...

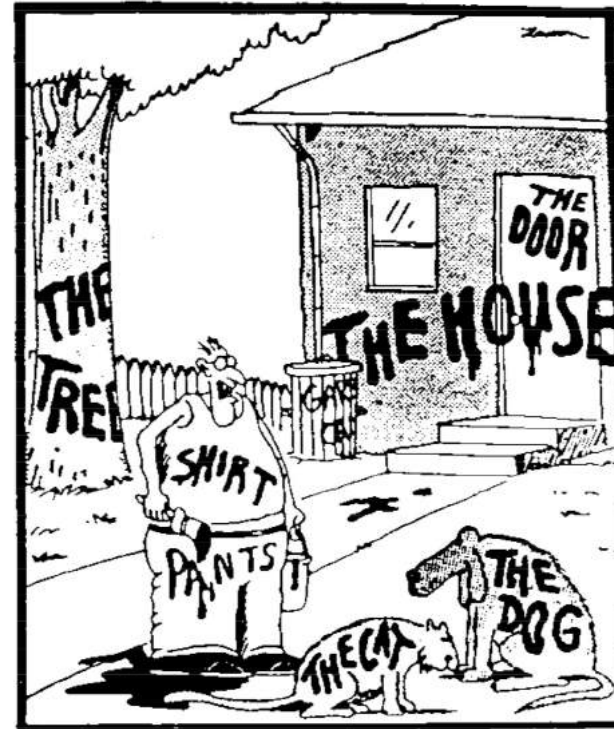

“Now! *That* should clear up a few things around here!”

What actually is a Concept Model / Data Model?

- A description of a business in terms of
 - **things** it needs to maintain records of – *Entities*
 - **facts about those things** – *Relationships & Attributes*
 - **policies & rules** governing those things and facts
- Models a view of the **real world**, not a technical design (therefore, stable and flexible)
- Can be comprehended by mere mortals (at least initially)
- Graham Witt – “A narrative supported by a graphic”

“Things” first,
data later!

Narrative component

Student definition:

A Student is any person who has been admitted to the University, has accepted, and has enrolled in a course within a designated time. Faculty and staff members may also be Students

Graphic component

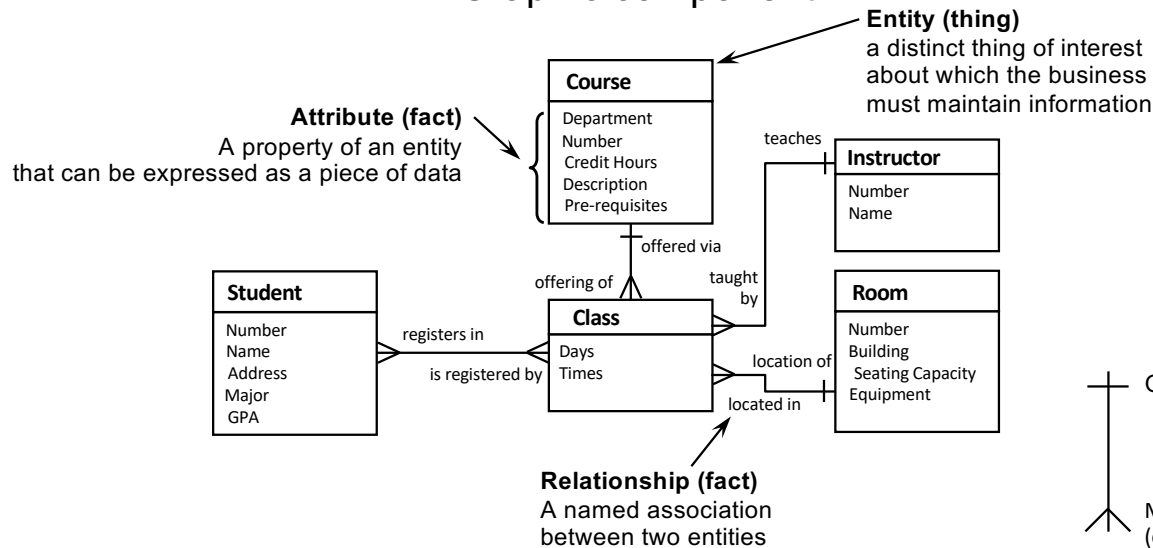

Plus “Assertions” (policies & rules)

- Each Course is offered through one or more Classes
- Each Class is an offering of a single, specific Course
- Each Instructor teaches one or more Classes
- Each Class is taught by one Instructor (which may or may not be true...)

Many rules can't be shown on the diagram...

- A Student can not register in two Classes of the same Course in the same Academic Term

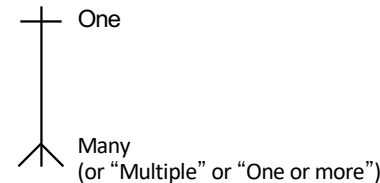

A better looking version of the model on the previous slide

Independent Entities at the top

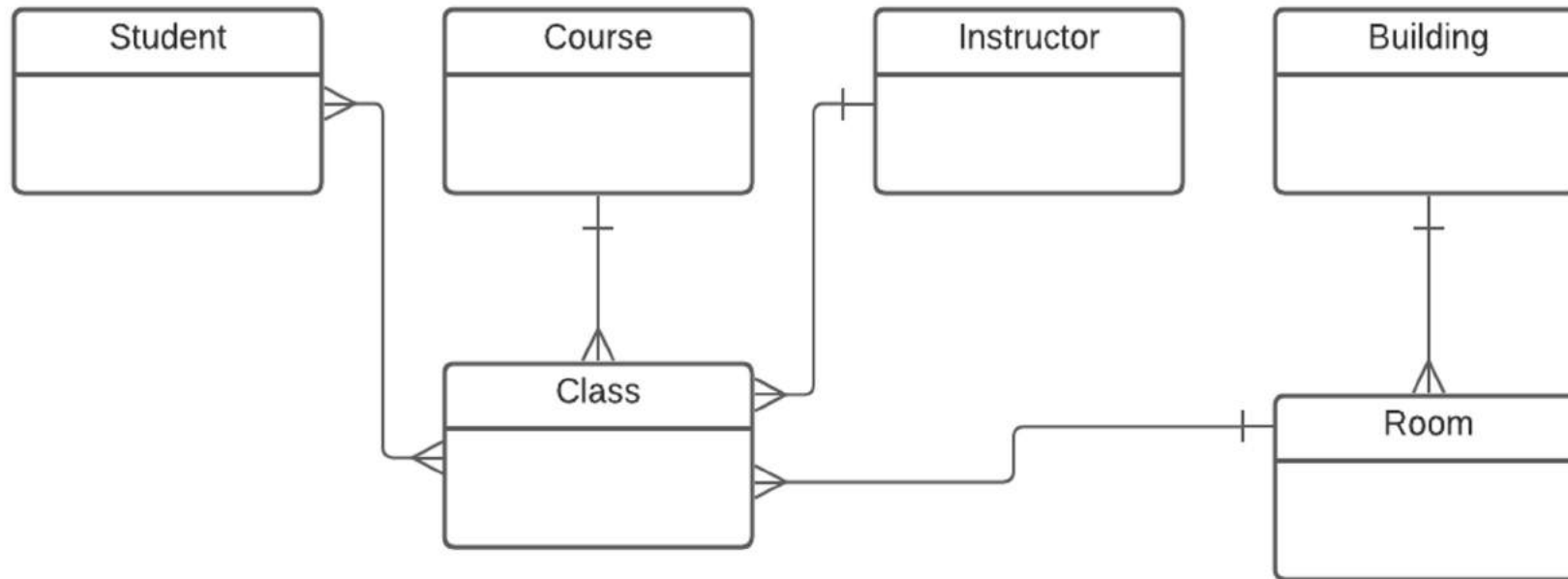

Drawn top-down by dependency



Concept Modelling principles

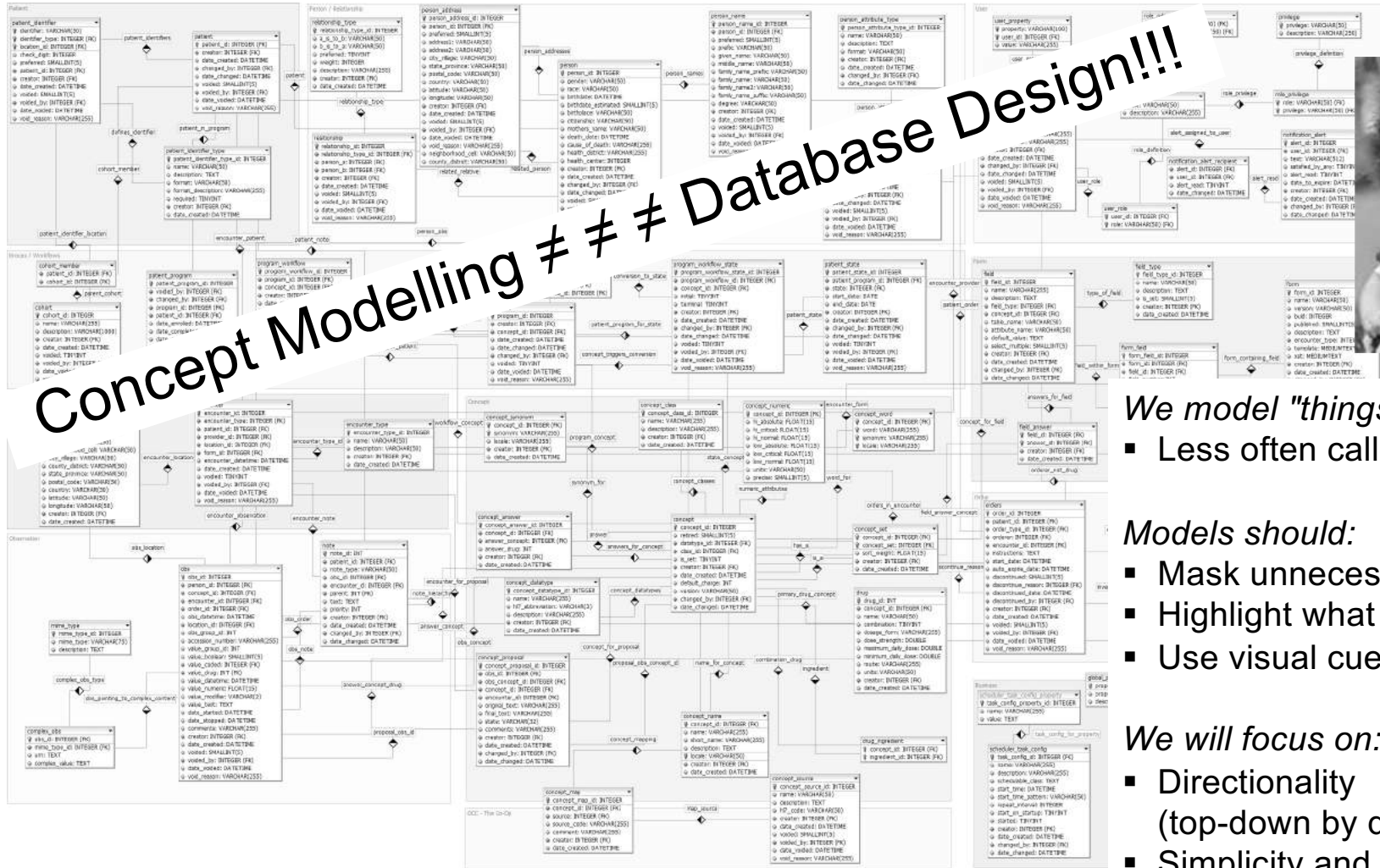

We model "things" before "data"
▪ Less often called "Data Modelling"

Models should:
▪ Mask unnecessary detail
▪ Highlight what matters
▪ Use visual cues consistently

We will focus on:
▪ Directionality
(top-down by dependency)
▪ Simplicity and abstraction
▪ Minimizing graphic "widgets"

Always start with terminology (the “things”)

From one-on-one interviews with 8 -10 key stakeholders we gathered ~200 terms related to CSMP (Client Safety Management Program) – “anything that went by a name.” Here are 24 that met the criteria to be a “thing” – an entity in a Concept Model.

Device	Client	Unit	Location	Company	Site
Applicant	Pressure Vessel	Operator	Owner	Boiler	Licensee
Slug	Operation	Verification	Customer	Plant	Inspection
Pig	Facility	Permission	Authorisation	License	Confirmation

*Tools like Miro and
Lucidchart / Lucidspark are
ideal virtual “post-it work”*

Identify synonyms and select one term.
How do these relate to one another?
What do you need to know about each?

Review from an example using Miro – Terminology Analysis

Terminology analysis (continued):

Let's arrange these terms into columns of synonyms. It's always a surprise for the business to see how many terms are used to describe the same fundamental thing!

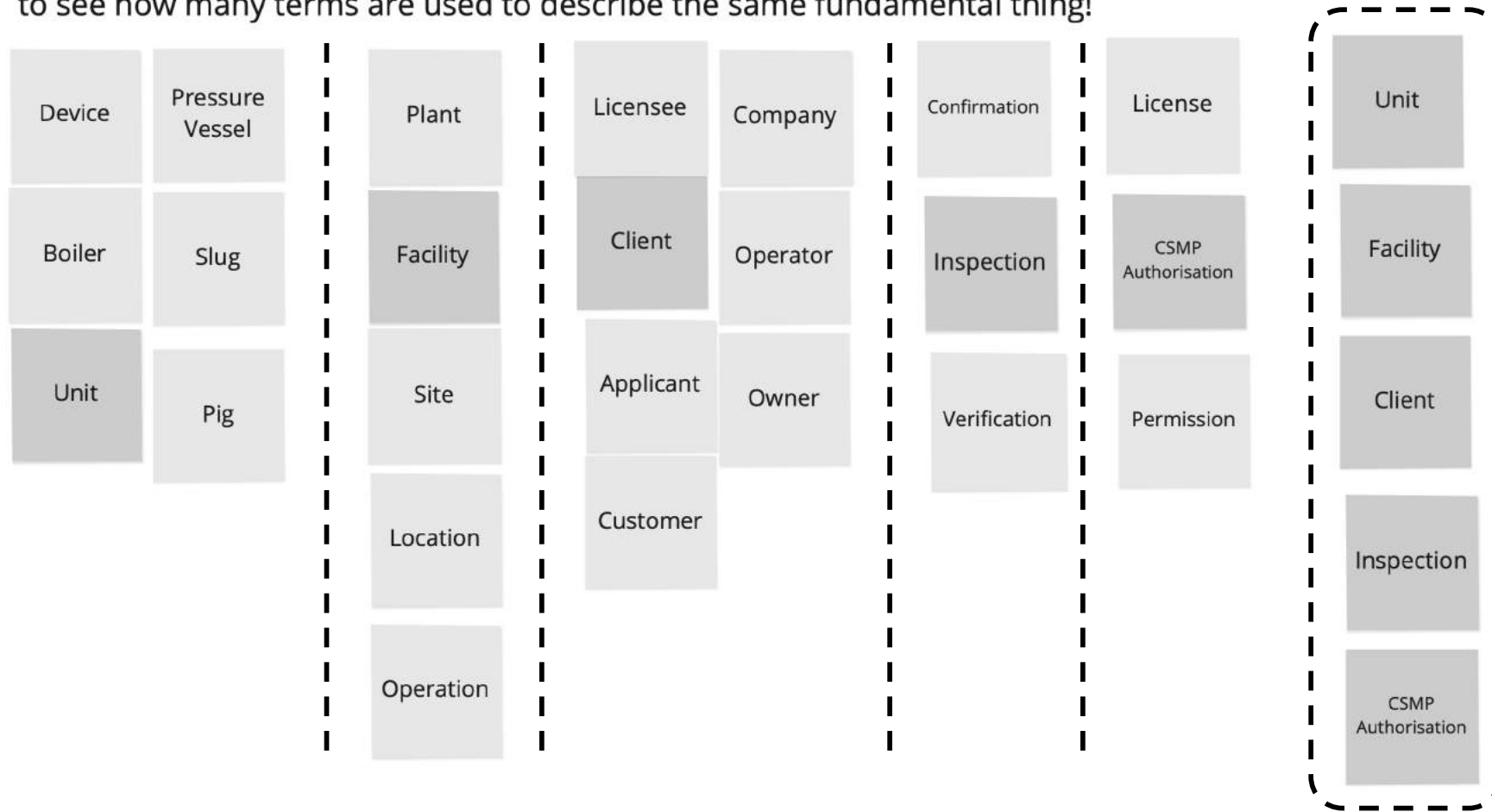

Concept Model Version 1; not perfect, but a good start

1. We arranged the entities / business objects by dependency
2. Then we drew relationship lines
3. Then we added a relationship name in each direction
4. Only then did we state (in words) the cardinality (1:1, 1:M, M:M) and then update the diagram with hash marks (†) and crow's feet (⌋)

Definition -

A CSMP Authorisation is a permission (or license) to operate a self-managed safety program (a Client Safety Management Program) at a specific Facility, for a specified time period, usually 1, 2, or 5 years.

The CSMP Authorisation is "all or nothing" - it covers ALL the Units at a Facility.

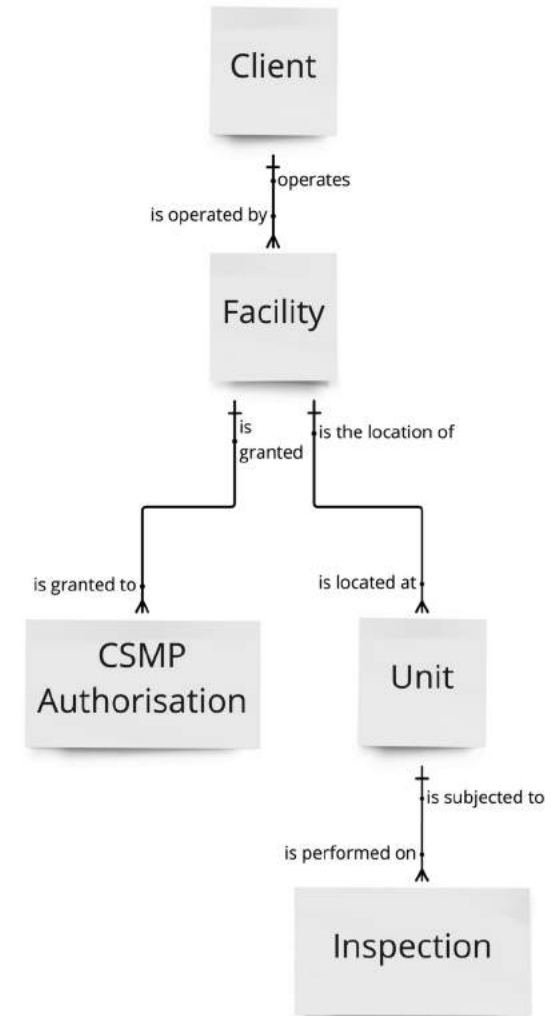

Just boxes and lines, but raises important questions

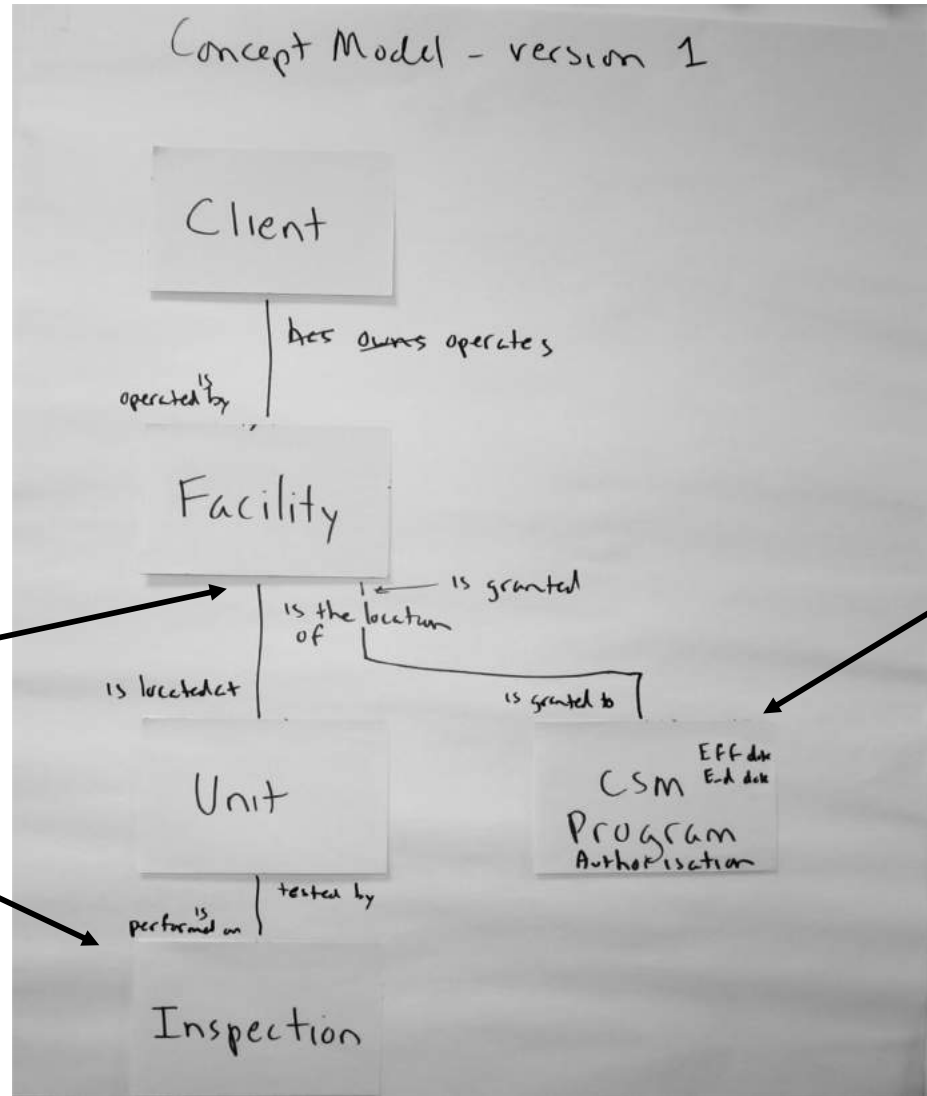

Are Units permanently part of one Facility?

What do we inspect?

What do we issue the Authorisation to?

Concept Model Version 1; state Assertions and challenge them

Now, state the relationships **emphatically** as Assertions. **Each** Client operates **one or more** Facilities! Then, **challenge** them!
Again, don't worry yet about **optionality** – whether the relationship **must be** or **may be** be present.
We only care now about the **maximum** – each ObjectA is related to a **maximum** of **one** or **one or more (or many)** ObjectB.

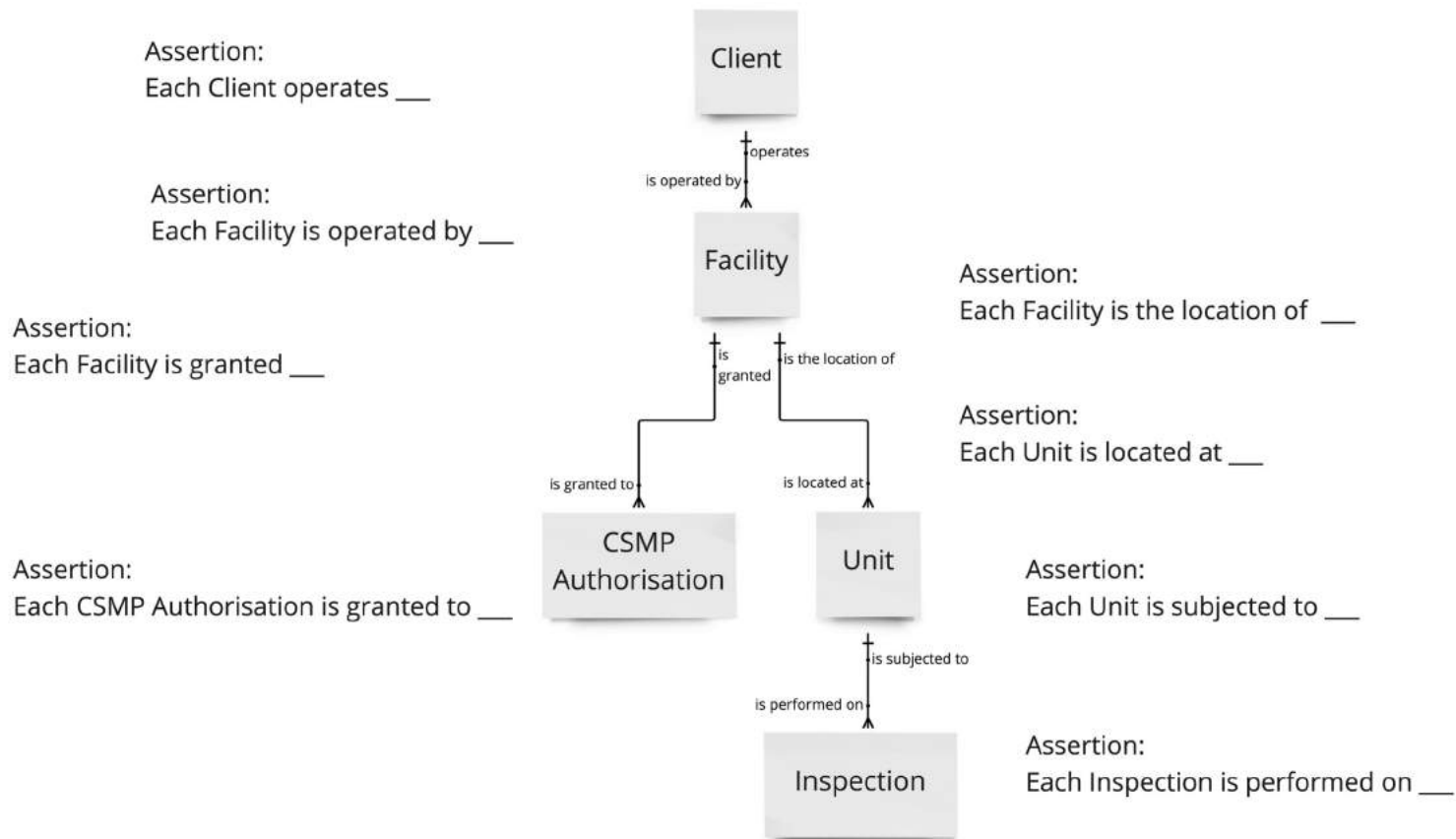

Concept Model Version 1; revised Assertions from challenges

Now, state the relationships **emphatically** as Assertions. **Each** Client operates **one or more** Facilities! Then, **challenge** them! Again, don't worry yet about **optionality** – whether the relationship **must be** or **may be** be present. We only care now about the **maximum** – each ObjectA is related to a **maximum of one** or **one or more (or many)** ObjectB.

Assertion:
Each Client operates
one or more Facilities

Assertion:
Each Facility is operated by
one Client

Assertion:
Each Facility is granted
one or more CSMP Authorisations
One CSMP Authorisation **at** a time,
but one or more **over** time

Assertion:
Each CSMP Authorisation is granted to
one Facility

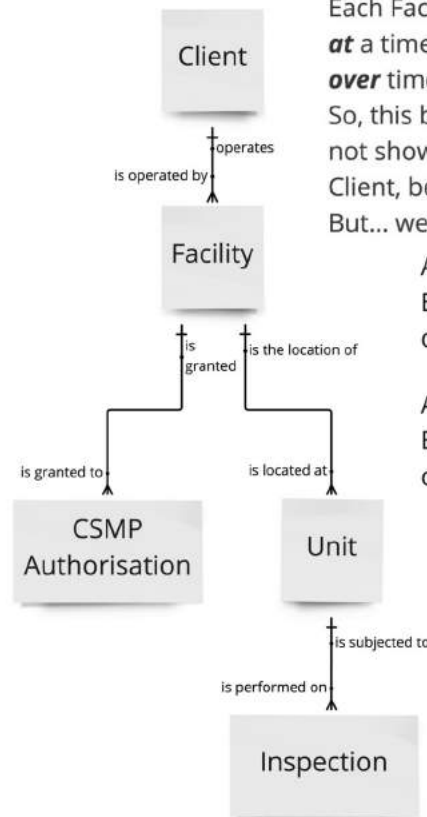

Each Facility is operated by one or more Clients **at** a time (Joint Ventures) and **over** time (changes in Ownership or Lease.) So, this becomes a M:M relationship, and we should not show a Facility as being dependent on a single Client, because a Facility is an independent thing. But... we don't always get our way!

Assertion:
Each Facility is the location of
one or more Units

Assertion:
Each Unit is located at
one Facility

Assertion:
Each Unit is subjected to
one or more Inspections

Assertion:
Each Inspection is performed on
one Unit

YES, but one or more Facilities **over** time, because Units can move between Facilities. So, this becomes a M:M relationship, and we cannot show a Unit as being dependent on a single Facility, because a Unit is an independent thing

Concept Model Version 2; revised from challenging Assertions

Now we will re-draw the initial Concept Model based on changes that came from challenging the Assertions in Ver. 1.

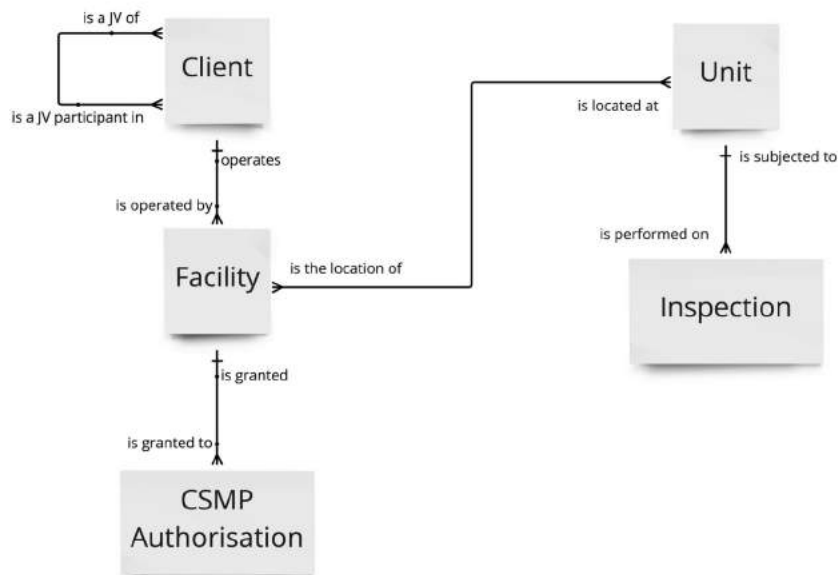

Note:

You don't always get what you *want* or what you think is the *right* thing in Concept Modelling. In this case the client (the Regulator) said they always wanted a Facility to be operated by ONE AND ONLY ONE Client.

If a Facility was operated by multiple Clients, they would require the Clients to form a new Joint Venture Client. This was to ensure that if there were legal difficulties, there was only ONE Client to go after.

Or, as they put it, "one throat to choke."

Later in the project, they realised they needed a history of the Clients that had operated a Facility, so the Client-Facility relationship became Many-to-Many, and Facility was modelled (correctly) as an independent Entity, as shown here:

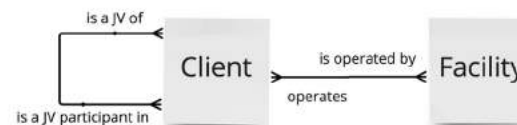

"What facts do you need in the Concept Model?"

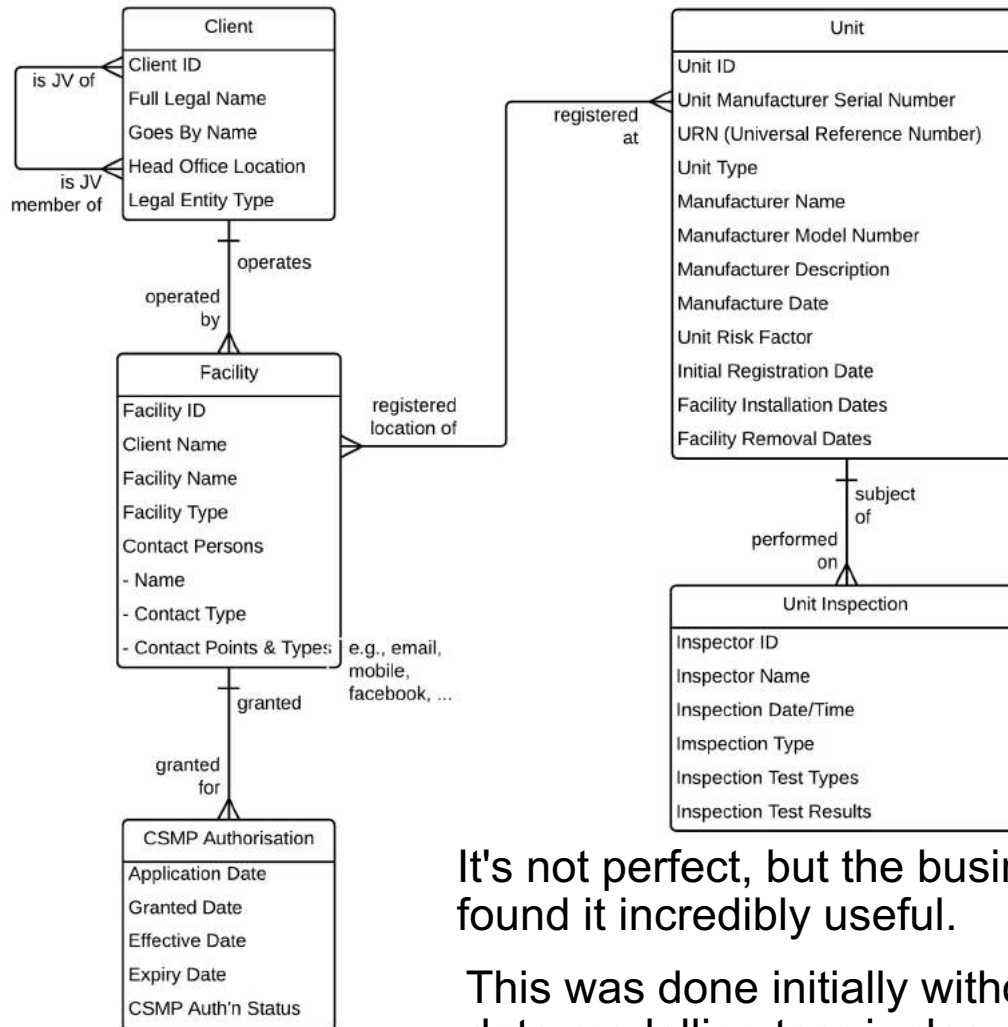

Sketching this out was *fast, and* raised many questions that had not occurred to the client...

- Is there one CSMP per Client, per Facility, or some other basis?
- Do Units frequently relocate, or even turn up at another Client?
- What is inspected – the Facility or the Unit?
- Does the CSMP cover all or some Units at a Facility?
- ...and MANY more...

It's not perfect, but the businesspeople found it incredibly useful.

This was done initially without any data modelling terminology or symbols!

Model took
~90 minutes

Identify an Entity, then Services / Events, then Use Cases / User Stories

Finally, we'll identify the Services (verb - noun pairs) we need, and the Use Cases / User Stories by which the Services will be accessed

What events happen to a Unit - what are the needed services? (Verb - Noun)

- ...
- ...
- ...
- ...

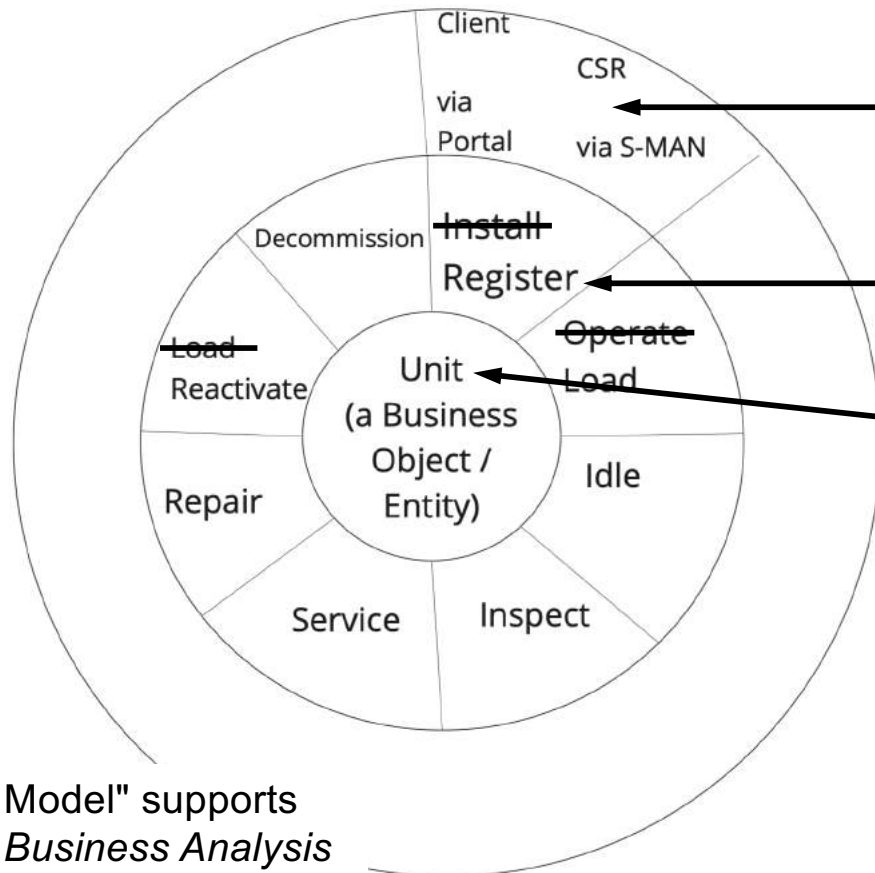

Who needs access to each Service, and How?

Use Cases

Use Case or User Story - add Who and How

Service Specification (Events)

Service (or Event) - add a Verb to the Noun

Concept Modelling

Entity or simply a "thing" - a core Noun

The "Doughnut Model" supports *Service-Oriented Business Analysis*

A Concept Model is a great starting point for discovering your Services and Use Cases (User Stories)

Discussion – one Business Service, one or more Use Cases

	Who	What (the Service – verb + noun)	How
Multiple Use Cases	Client	Register Unit	via Portal
	Customer Service Rep (CSR)	Register Unit	via S-MAN (the ERP)
	Client	Register Unit	via Mobile App
	???	Register Unit	???

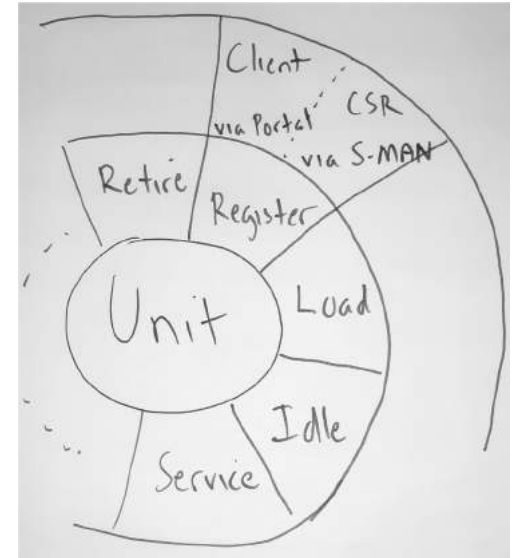

What is the value of documenting the Service only *once*?
("One Service available through multiple channels.")

- re-use of the asset, and therefore higher consistency
- better chance of getting it right – higher value from less effort
- if it's implemented as a single service, easier maintenance – it's in ONE place.

Why would we make a *single* Service available via *multiple* Use Cases?

- different actors need different "navigation and hand-holding,"
e.g., casual vs. expert users
- different technology platforms have different capabilities,
e.g., mobile phone vs. touch-screen kiosk

Recap – what can an analyst do with a Concept Model?

First, clarify language. (A platform)

Second, establish policies and rules.

Then, identify events or services, e.g.,

A Unit is...

- Registered (requiring the service “Register Unit”)
- Loaded (requiring the service “Load Unit”)
- Idled (requiring the service “Idle Unit”)
- Reactivated (requiring...)
- Repaired
- Inspected
- Relocated
- Retired...

*These are the
essential capabilities*

*Something I always do when
evaluating/selecting COTS S/W*

We did the same for Client, Facility, CSM Program, ...

Develop high-level Services then Use Cases

Service: Register Unit

- Check for presence of properly formatted UR Number
- Determine if Unit UR Number is previously known
- If known, has it (a) moved (b) changed ownership (c) ...?

Use Case: CSR Register Unit via S-MAN

- CSR will select “spreadsheet” of all Units covered by CSMP application
- S-MAN will highlight all that can proceed immediately
- For each category of Units requiring intervention...

Note:

Services and Use Cases were described at a very high level (“upper conceptual”) to provide the vendor with key requirements and avoid the usual bulleted list requirements document. *They loved them!*

Clarify scope of the new process and identify participants

Trigger:
Client submits
request to
enter into
a CSMP



Client Result:
Approval granted for
a self-managed
safety program.

Agency Result:
Revenue collected.
New participant in
CSMP; confirmation
that regulations are
satisfied

Cases:

- New
- Legacied
- Ownership Change

Process Scope Model – pure “what”...



Process Summary Chart – simplified “what,” plus “who”

We saw this example earlier

The initial, business-friendly workflow model

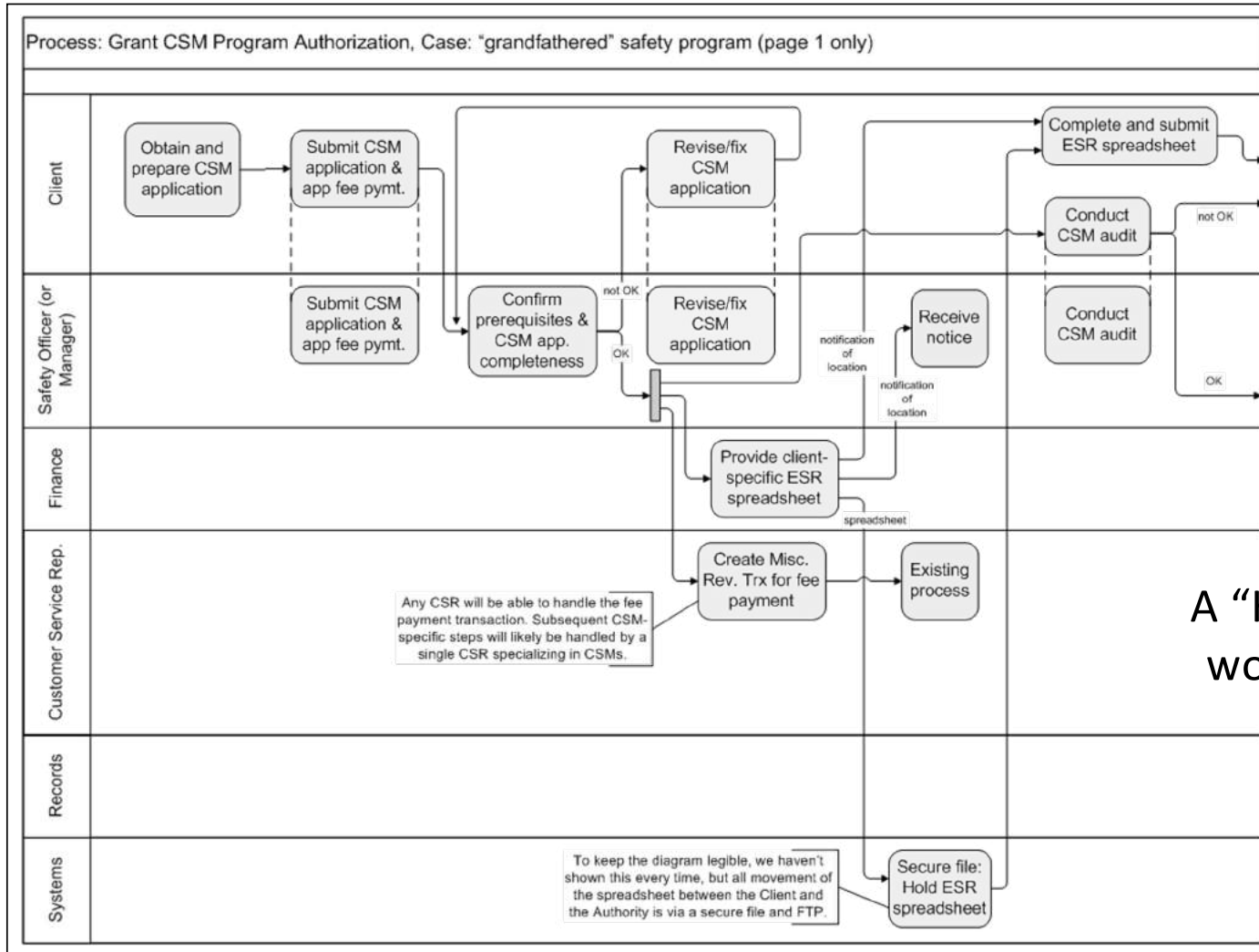

A "Handoff Level" workflow model

Then detail showing where use cases & services fit

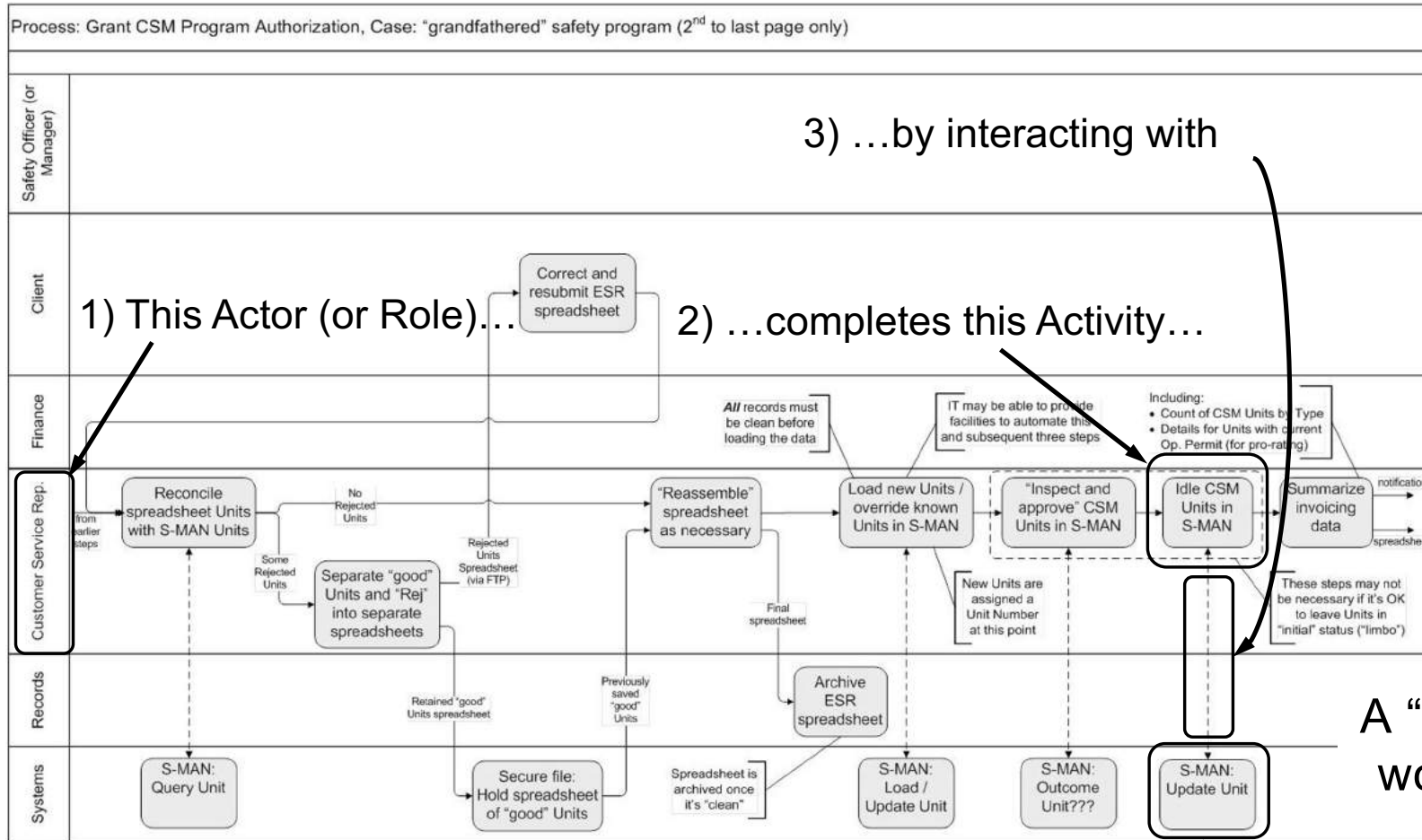

A "Service Level" workflow model

Mission accomplished! Conclusions:

- "Plan A" rejected – agreement that Unit data *must* get into S-MAN
- "Plan B" (change the app) looks good, but the vendor estimates are *HIGH*
- "Plan B Minus" (existing functionality plus CSR work) is *worth the cost*

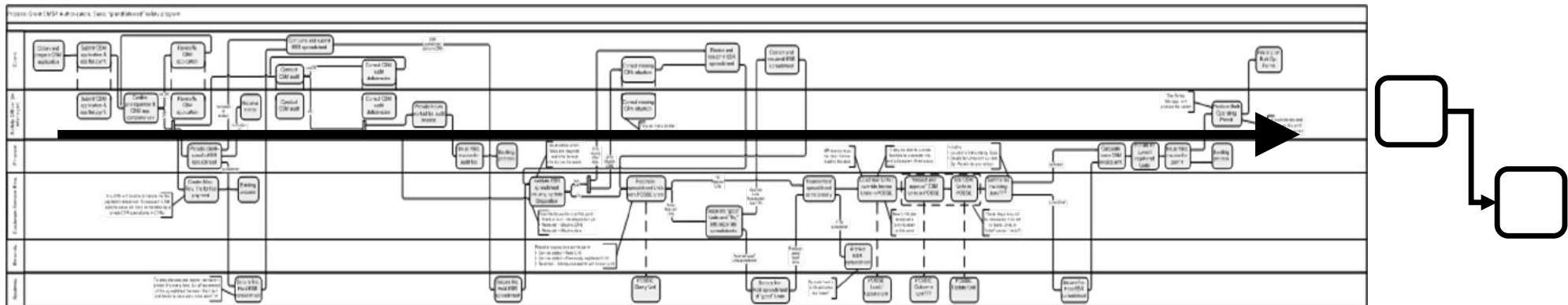

1. If requirements, issues, assumptions, etc. are in lists, people will argue endlessly; if they are in an *integrated* set of models, it's much harder to dismiss the reality of the situation
2. Process Models, Use Cases, Service Specs, & *Concept Models: essential!*

A look ahead – from Concept Model to Logical Data Model

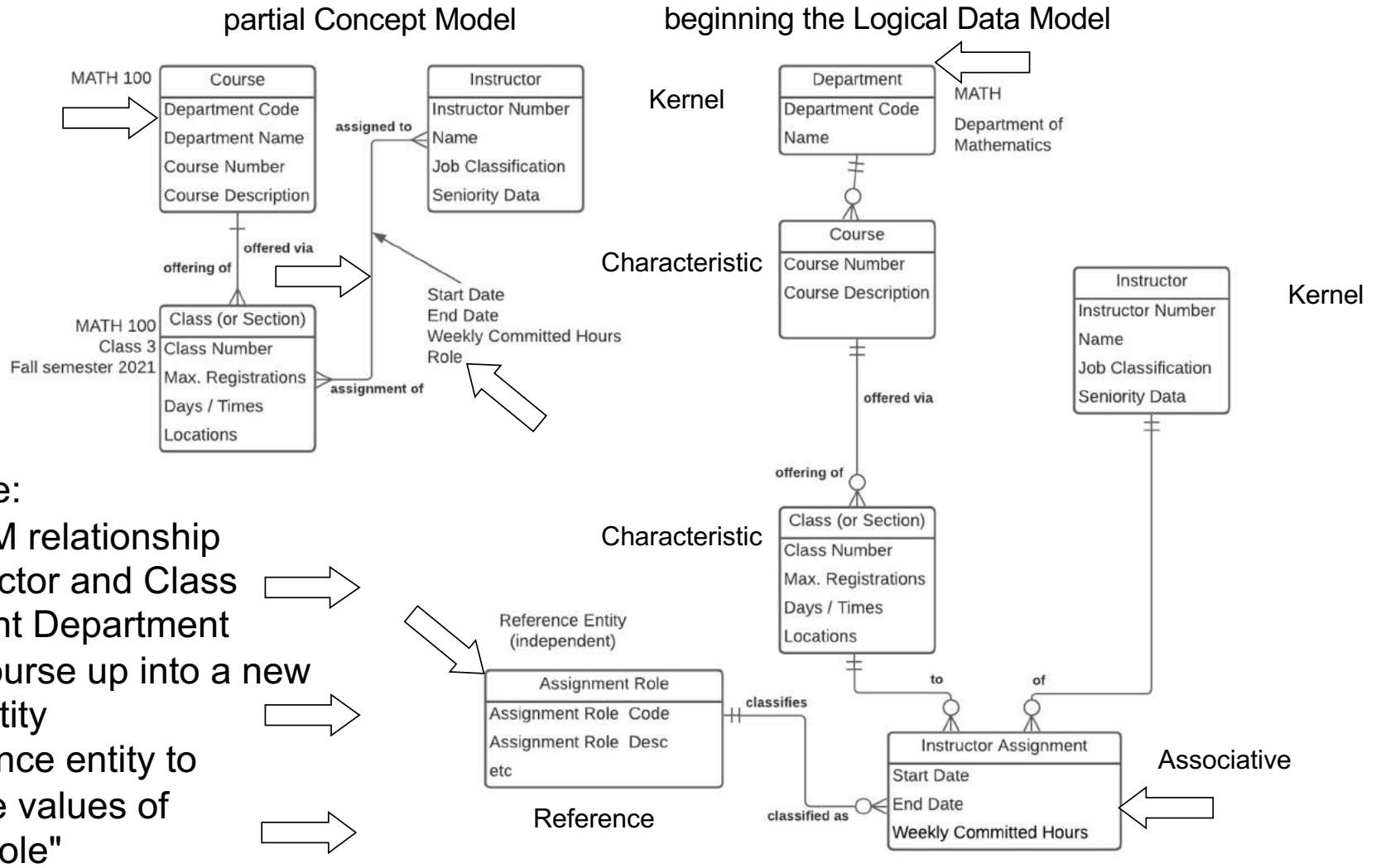

In this example we:

- resolve the M:M relationship between Instructor and Class
- move redundant Department attributes in Course up into a new Department entity
- create a reference entity to standardise the values of "Assignment Role"

More examples: Example 1 – Concept Modelling to clarify the process

Analyst struggles to model “Evaluate Education” – timing disconnects, 1:M and M:1 connections within the process, token changes, ...

A few minutes of Concept Modelling showed two distinct tokens and processes. “Education” was a “mushy noun.”

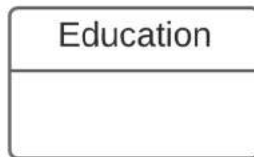

Processes:
Evaluate Education???

Not a good entity name, therefore not a good noun in a "verb - noun" process name.

- It's not a *singular noun* we can imagine *single instances* of.
- "What is *an* education?" or "What is a *single* education" doesn't sound quite right.

WELD 101
Introduction to
Overhead Welding

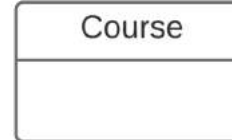

Processes:
Develop Course
Evaluate Course
Retire Course

WELD 101
Nov 07-09 2017
MPL Main Campus
Room T-2114

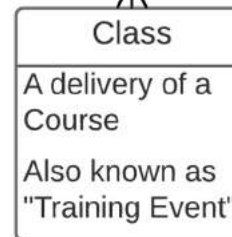

Processes:
Schedule Class
Enrol Participant in Class
Conduct Class
Evaluate Class

Example 2 – Concept Modelling to clarify the process

A session to model the “Design Component” process at a pipeline operator is going in circles. Concept Modelling clarifies the company doesn't actually “design components,” they:

- Develop Component Type Specifications
- Approve Manufacturer Make/Model (“AML”)

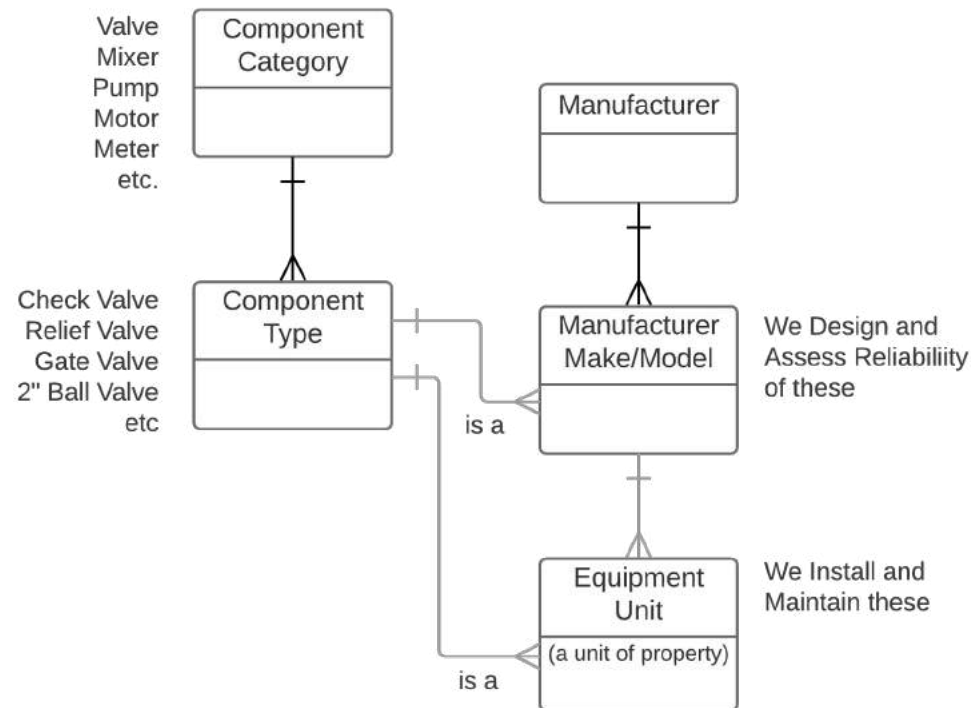

Example 3 – a Process job becomes a Data job

- Assignment – improve broken Consumer and Online Advertising processes in a \$6B media firm
- Early realisation (30 minutes) – inadequate data was the real problem, so we started concept modelling
- Everyone talked about “Customer,” so we asked the classic “dumb” question “What is a Customer?”
- Modelling showed there was *no “Customer” entity managed by the business.*

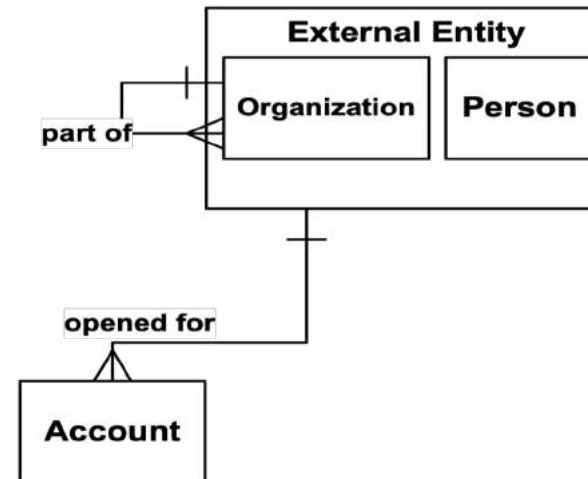

- Everyone talked about “Team” – same situation
- Focus shifted to developing the “MAL” – Minimum Attribute List

Never be afraid to ask “dumb” questions...

- Myth -

“I've got to have all the answers. I can't show my ignorance.”

Just one more question, ma'am. Nothing too important...

Could we go over this just once more to be sure I've got it right?

There's one thing I'm not clear on...

Lieutenant Columbo takes up Data Modelling

- Reality -

You're paid to **ask**, not to **know**
Someone will be glad you did
The number of different answers will surprise **everyone**
Classic example –
“Case” in a justice system



“What do you mean by...?”



Reporting to the executives

Issue

- Data is distributed in a multitude of systems (300+) with inconsistent definitions, management policies, accessibility, quality, formats, etc.
- This makes our suite of *business processes* and *applications* FAR more complex than they need to be
- Fundamentally, we manipulate and massage data, but don't manage it
- This leads to general and very specific unhappiness

Overall goal

- Implement a managed data environment (“DMI”) for core data
- This will enable a central point of management and establishment of BI environments

This week's objective was met

- Initial concept model for core Campaign data (Customer, Account, Team, Contact)
- Initial development of roadmap

Initial "Concept Plus" Model

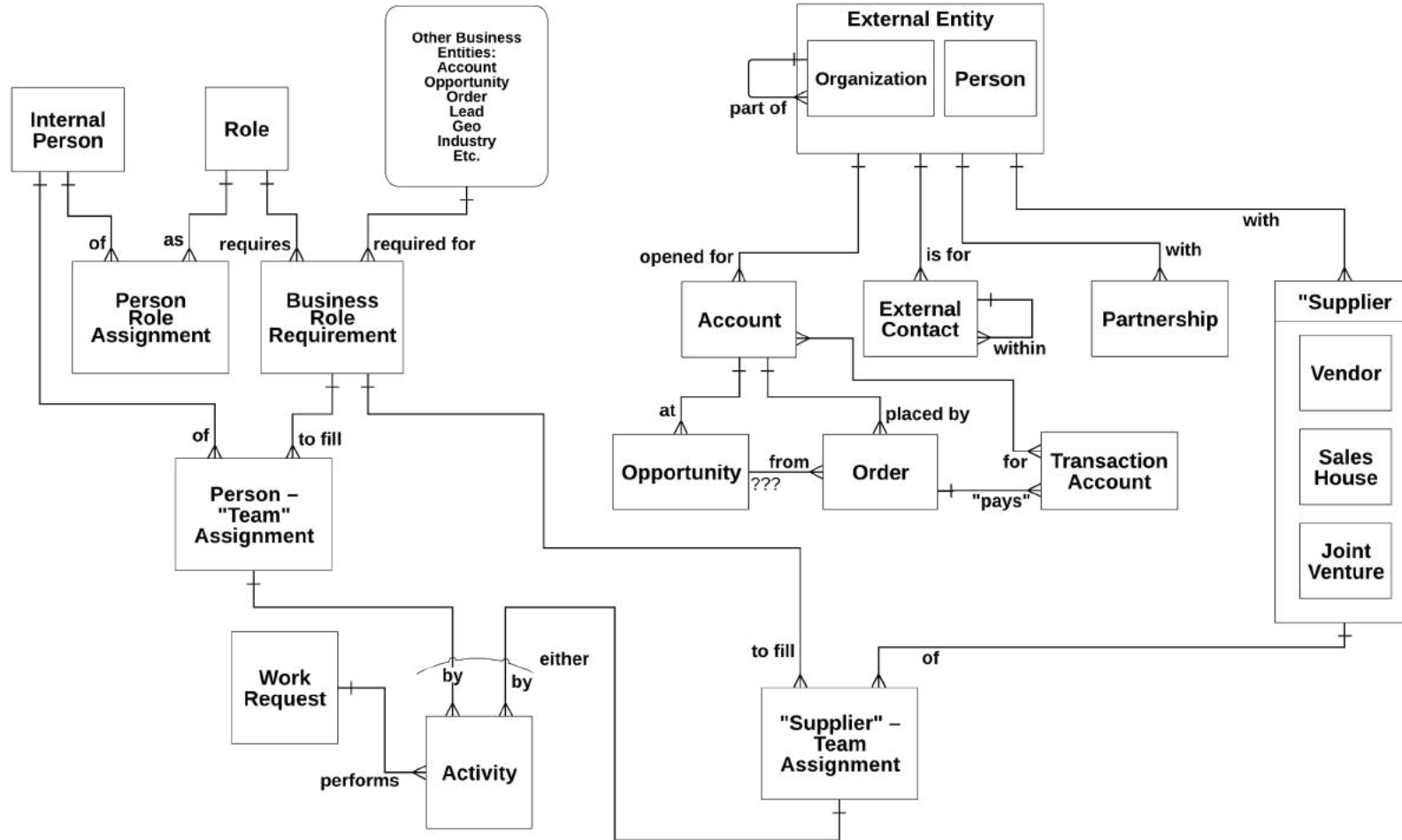

Key achievement – clarity

Clarified that **Customer** is not something we manage –
it's a “view” of two fundamental things we manage, or *should*, manage:

External Entity

A person or organization (a legal entity) with which we have or wish to have a business relationship. This includes past, present and future (prospect) relationships. Legally, an organization is either a company, a partnership (e.g., a law firm or accountancy), a society (e.g., Red Cross) or a government agency (e.g., City of Seattle.) An organization may be structured into a hierarchy of subsidiary organisations to whatever number of levels we wish to manage. Other types of relationships among organisations are possible (e.g. ownership, collaboration, ...)

Account

An account is a record-keeping mechanism through which we organize our business interactions (such as Orders or Opportunities) with External Entities. Accounts can be arranged in a hierarchy of Accounts.

*For the first time, the business was discussed in terms of business entities, not systems!
Only now is real process change possible.*

Example 4 – application in Process & Big Data

A useful concept model can be built quickly...

- Major US print newspaper making transition from print publication to digital content clearing house
- Need new processes, and a CMS (Content Management System)

They take one of my workshops to learn about business modelling – process, data, events, ...

- Did some class exercises using CMS as an example
 - Q: “What is *content*?” A: “Everything.”
 - Q: “What is a *single piece of content* called?” A: “Huh?”
 - Q: “What *happens* to content?” A: “Lots.”
 - ...
- We spent 30 – 40 minutes getting everyone on the same page by starting a “Content Concept Model”

A quick brainstorm on “Content”

“Content” ★

- Archive
- Content in the paper
- Photos
- Editorials
- Ads
- Sports Scores
- Newsletters
- Blogs
- Comments
- Web Rank
- Bylines
- Crosswords
- Comics
- Web Traffic
- Readership

- Fact Boxes
- Author
- Editor
- Twitter / Facebook
- RSS Feed
- Source
- Page
- Section
- Position
- Electronic Editions
- Category
- Domain
- Words (count)
- Links (to Comm blogs etc)
- Versions (History)
- Updates

- Who made it
- Headlines
- Size
- Product it ran in (Print, Web, Section, ...)
- Summary
- Credit
- Date
- Resold (Resellable)
- Permissions (resell, print, distribute, ...)
- Page (printed or web)
- Video
- Type / Format
- Graphics
- Maps
- USB UGC
- Costs

- Syndication
- Deadline
- Rate or Cost
- Page Plan
- Presses

Maria asked
“Where's 'Article'?”

Define key "things," ID main events

Product - a ^{mechanism} ~~channel~~ through which we deliver content.

- Web Page
- Printed Paper
- Newsletter
- RSS Feed
- Electronic Edition
- Kindle Feed
- Nook Feed
-

Content Item is ...

Ingest · encode · transcode ·
syndicate } distribute

- edited
- written
- updated
- publish
- archive
- searched
- validated (assess)
- scheduled content item
- identified content
- assign ~~character~~
- shared
- restored
- promoted
- placed
- banned
- assimilated
- ingested

A first cut Concept Model – all in <40 minutes

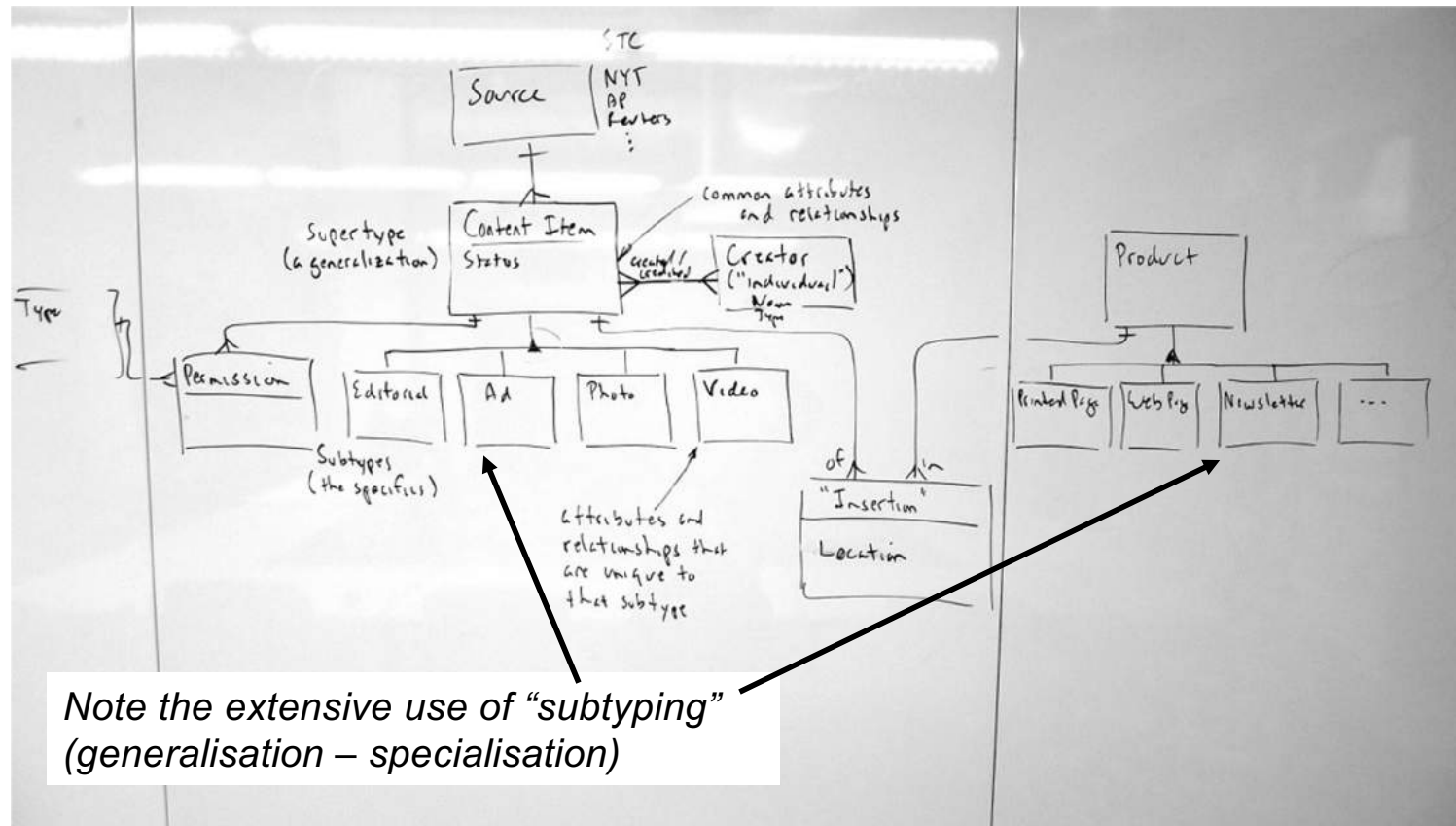

Now have a common language,
an understanding of how things hang together,
and even some essential requirements

Later... data modelling for Big Data

Client moving into Content Management,
Product Lifecycle Management, Clickstream Analytics, ...
Happily using cool new terminology...

- Content and Product
- Product Owner
- Audience and Customer and User
- Audience Segment
- Behaviour and Consumption
- Behaviour-based Segmentation
- Sales Funnel
- Call to Action

But... no one knew or agreed what these meant!

Start with a road map – contextual model

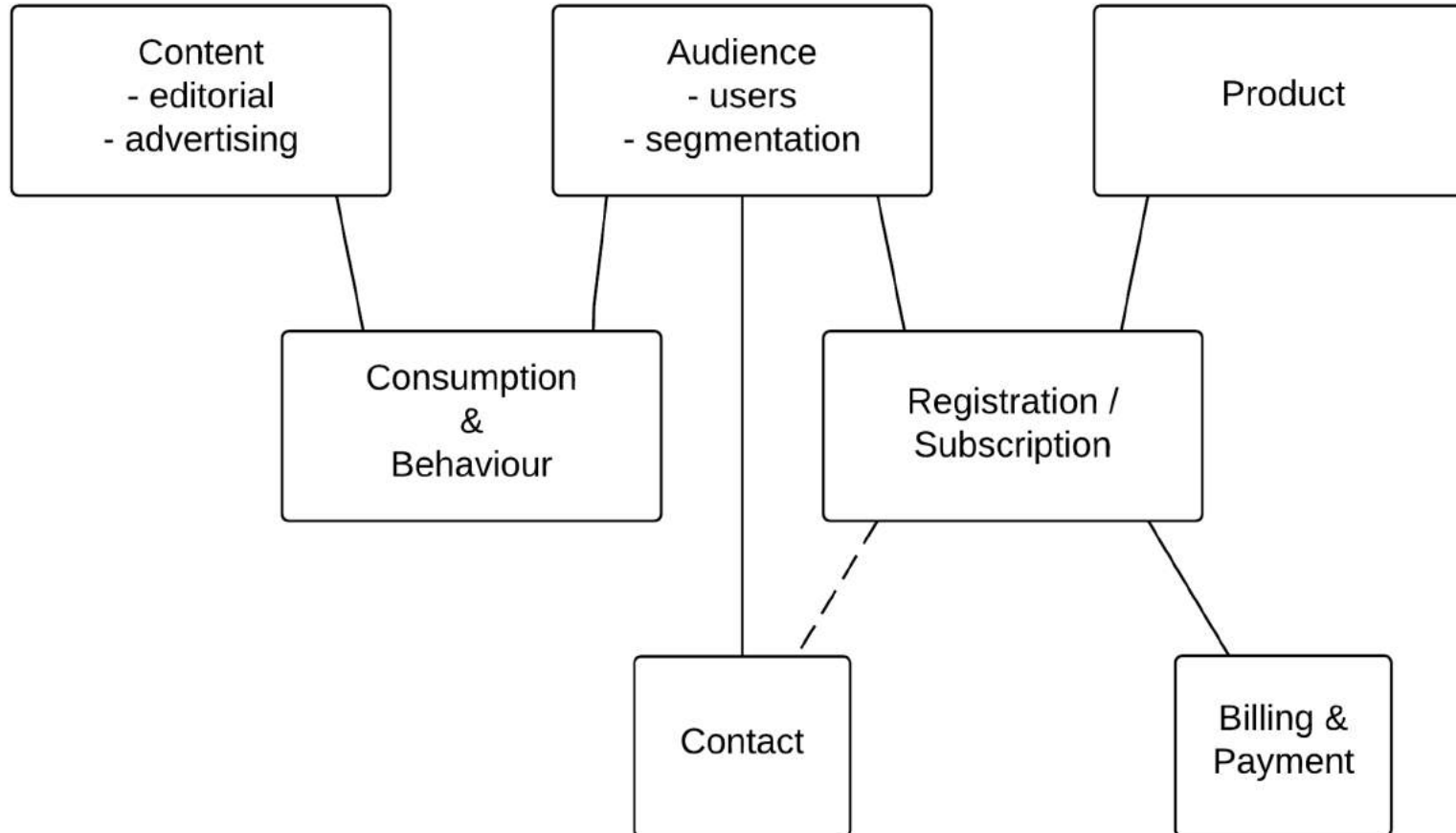

Developed “conceptual plus” models e.g., “Audience”

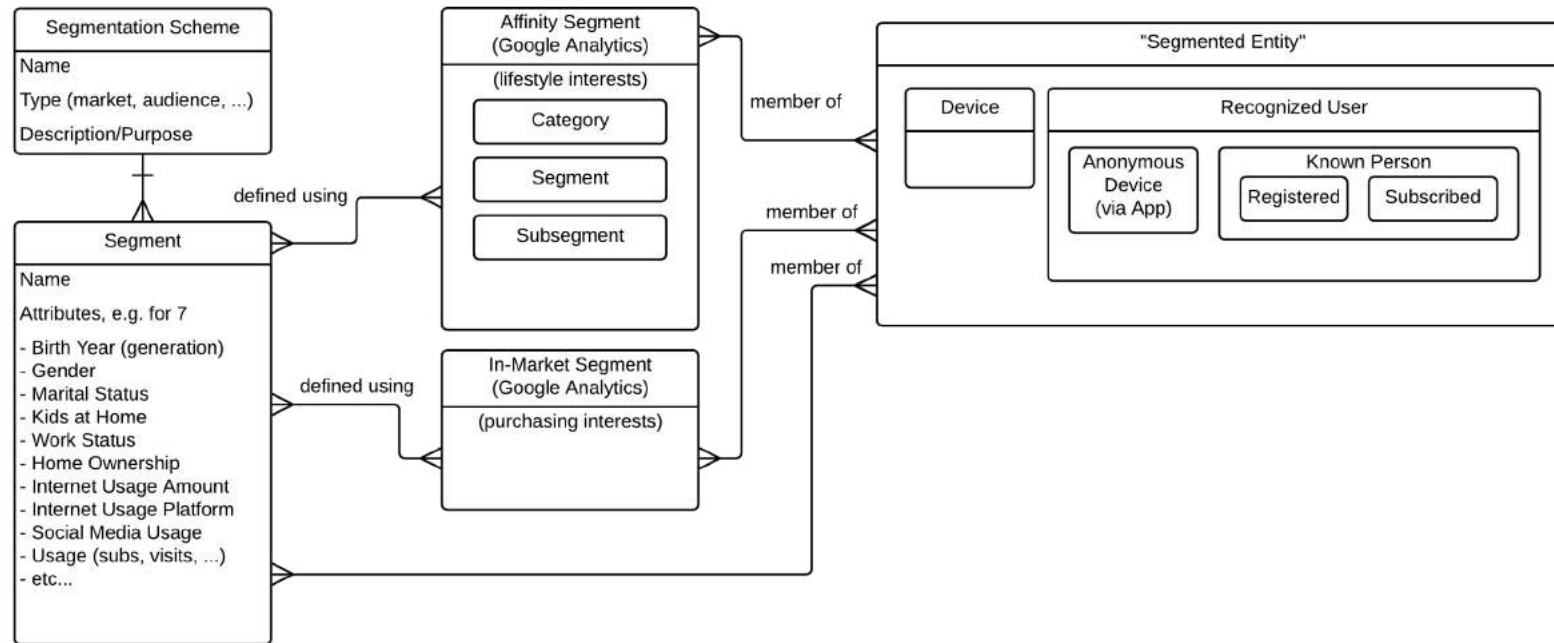

E.g., “Product, Subscription, Person, & Contact”

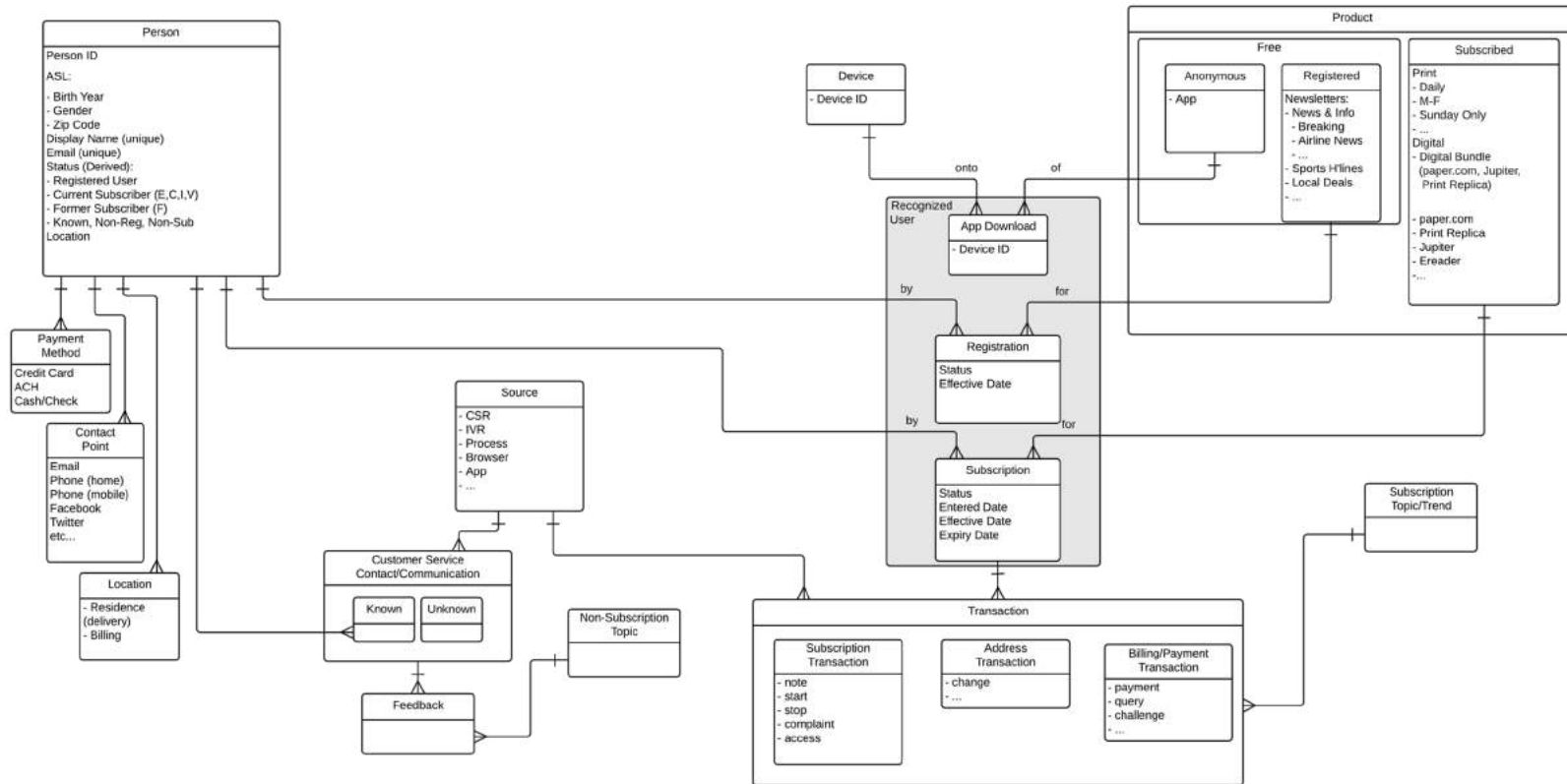

E.g., “Content, Consumption & Behavior”

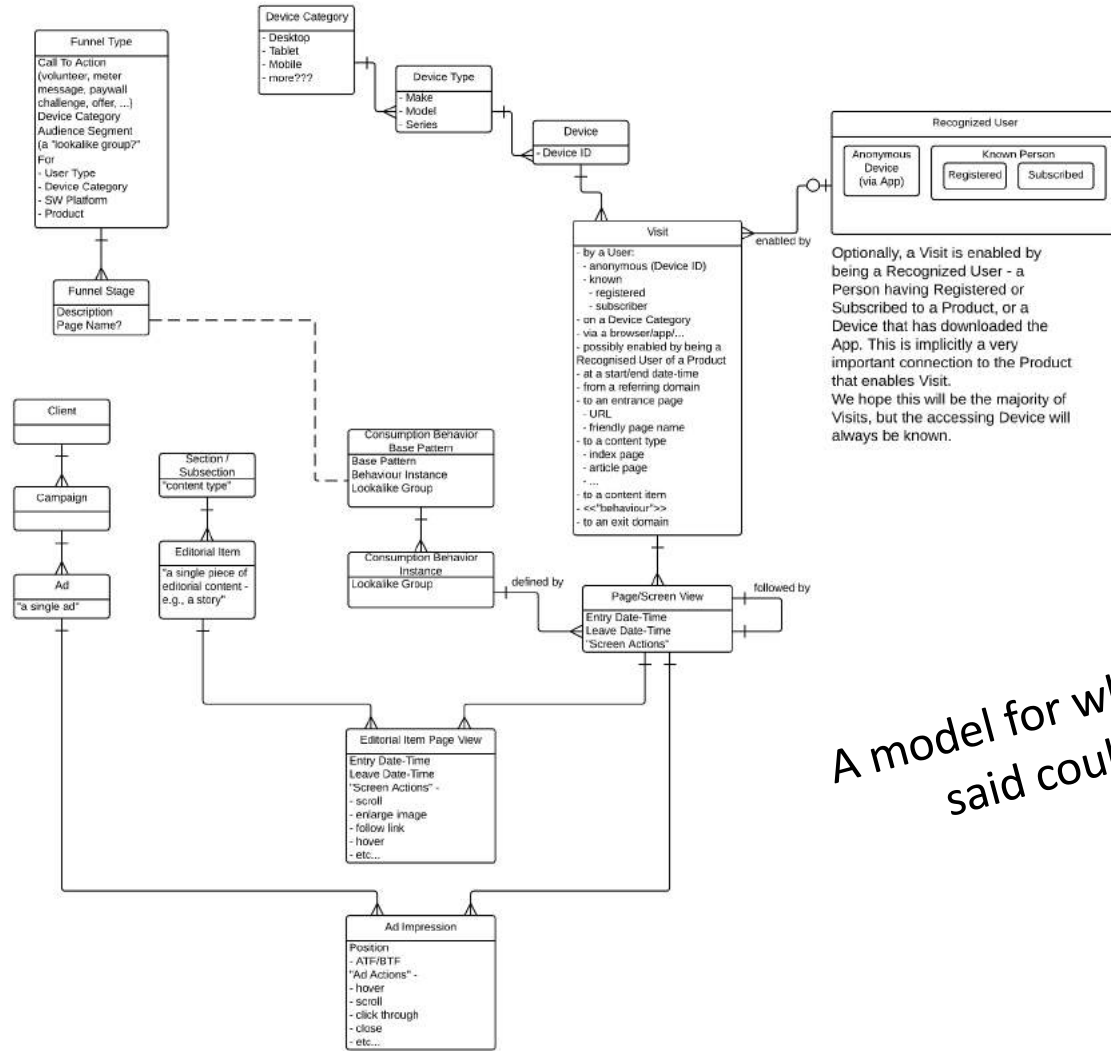

A model for what the "Big Data" folks said could not be modelled

Example 5 – is a new process concept viable?

Classroom tech support at major US research university

- Goal: “Uber-style” tech support for classrooms – when an Incident is raised in a Classroom, dispatch it to one or more appropriate Techs (qualified, available, assigned to the appropriate Support Unit) who will bid on it.
- Approximately 20 “assertions” described the planned state:
 - Each Tech may be badged for one or more Service Category Levels, and for each Service Category Level there may be one or more Badged Techs.
 - Each Tech may be assigned to one or more Support Units during a given time period, and for each Support Unit there may be one or more assigned Techs. A Tech can only be assigned to one Support Unit at a time.
 - An Incident for a particular Classroom can be raised by either a Customer (the “reporter” – Faculty, Staff, Tech, ...?) or an automated Alert raised by an Equipment Unit located in a particular GP Classroom.
 - many more...
- The assertions led to the development of an ERD.
Note – the complete “Concept Model” is the combination of the definitions, the assertions, and the graphic (ERD)

Example 5 – Assertions. Lots of assertions.

Classroom Support

Assertions, for review and validation:

- Support is provided by different Support Units (organizations) for different Service Levels (tiers) and different Service Categories (Computers, Audio-Visual, Learning Technologies, Networking, Scheduling, and Facilities.) We are concerned with support for Computers, Audio-Visual, Learning Technologies, and Networks. Scheduling is supported by the Registrar’s Office, and Facilities is supported by (shockingly) Facilities.
If we only cared about one Service Category, say “Computers,” there would be no need to model the “Support Category / Support Unit” concept, because it would be a given – there would only be one.
- Each Support Unit could support one or more Service Categories. E.g., Sam’s Call Center provides Tier 1 support for Computers, Audio-Visual, Learning Technologies, and Networking.
- Support for Department-owned rooms is not within the scope of this initiative; support will be provided by the owning Department’s Local Support Unit.
- Support for Classrooms (GPC and non-GPCs) or a Room Block of GPCs will be provided by a Support Unit during a Time Block for a Support Level (Tier.) That is, for a given Room Block (available via the Classroom reporting the Incident) for a given Service Category Level (e.g., Computers – Tier 1) during a particular Time Block, a particular Support Unit will provide support. This concept is represented via the “Support Responsibility” concept, an associative entity which indicates the responsibility of a Support Unit to provide support for a Service Category Level for a Room Block during a Time Block. There are three general possibilities:
 1. Support for the Room Block will be provided exclusively by the Local Support Unit (the Department);
 - this only applies to non-General Purpose Classrooms (Department “owned”)
 2. Support for the Room Block will be provided exclusively by the Central Support Unit;
 - Will this happen? Is this a goal?
 3. Support for the Room Block) will be provided by the Local Support Unit during “normal business hours” (a Time Block) and by the Central Support Unit outside of “normal business hours.”

Classroom Support

- Is this the “normal” case?
- Should it read “after normal business hours?” That is, will Central ever provide support both before and after normal business hours?
- Each Tech may be badged for one or more Service Category Levels, and for each Service Category Level there may be one or more Badged Techs. A M:M relationship.
- Each Tech may be assigned to one or more Support Units during a given time period, and for each Support Unit there may be one or more assigned Techs. A M:M relationship, but will a constraint be that a Tech can only be assigned to one Support Unit at a time?
- An Incident for a particular GP Classroom can be raised by either a Customer (the “reporter” – Faculty, Staff, Tech, ...?) or an automated Alert raised by an Equipment Unit located on a particular GP Classroom.
- The “dispatcher” or “CSR” at Room Support (?) assigns (or routes?) an Incident to the appropriate Support Unit based on the Support Responsibility.

Putting all this to work...

The goal is to automatically route an Incident to one or more Techs. When an Incident is raised, Dispatch will always create a Ticket, and then route it to the appropriate Tech(s) based on Service Category Level (Service Category and Service Level,) Time Block, Room, and Support Unit. Here’s how...

- When an Incident is raised, we know the Room Block (via Room,) the Time Block, and the Service Category Level, therefore we know the Support Responsibility, and therefore the Support Unit.
- We also know which Techs are badged for that Service Category Level, and which Techs are assigned to that Support Unit at that time.
- Now we have a pool of Techs the Incident could be dispatched to, for them to “bid on,” Uber-style.

The underlying "Concept Plus" Model

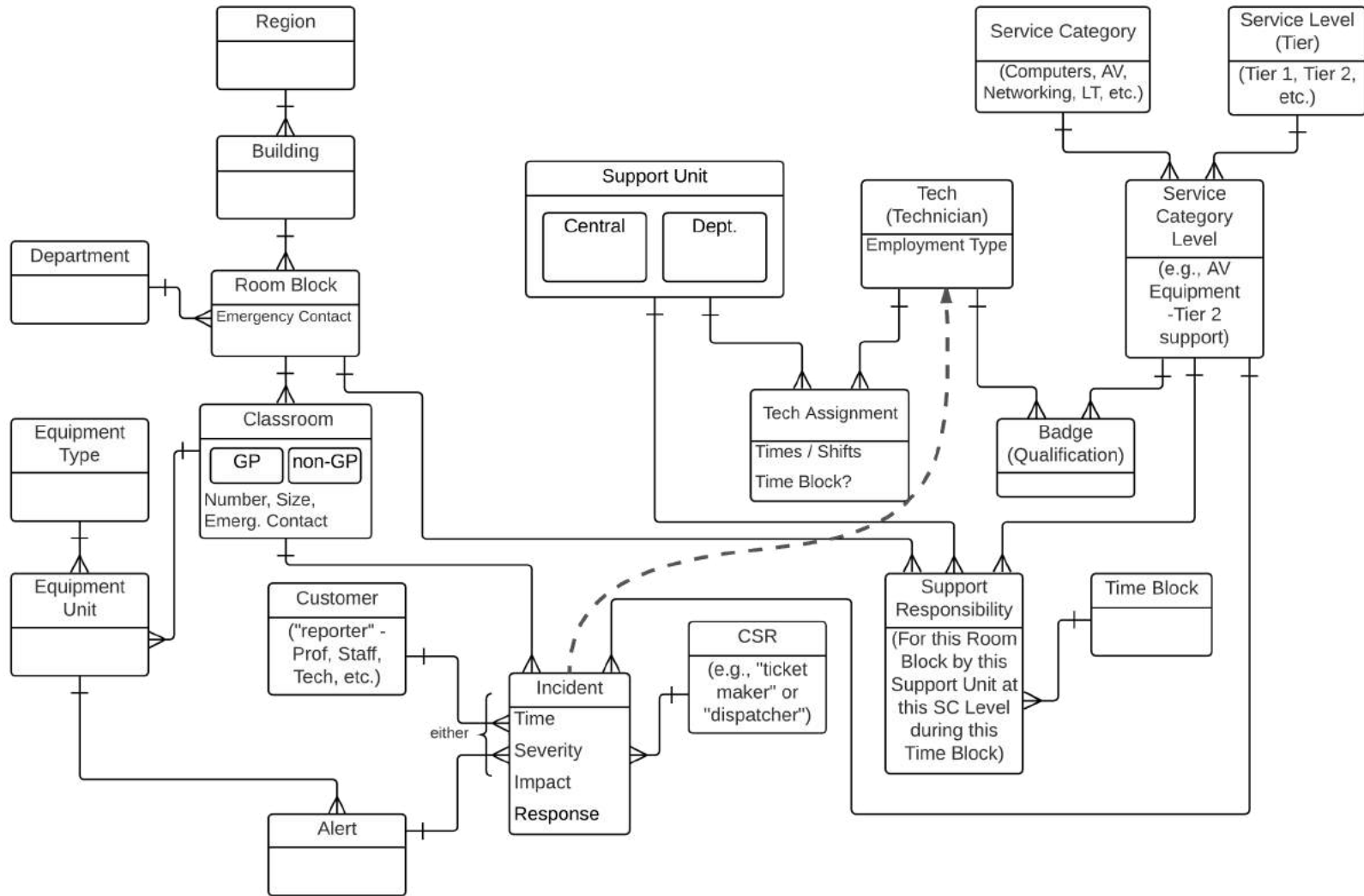

Summary of findings

The assertions and the ERD showed the idea could be implemented:

- When an Incident is raised, we know the Room Block (via Room,) the Time Block, and the Service Category Level, therefore we know the Support Responsibility, and therefore the Support Unit.
- We also know which Techs are badged for that Service Category Level, and which Techs are assigned to that Support Unit at that time.
- Now we have a pool of Techs the Incident could be dispatched to, for them to “bid on.”

Using a Process Architecture in planning process work

Current state

- problems or issues
- changes in context
(business environment)

Future state

- goals and objectives
- regulatory mandate

Execs typically start here or here.

Your role is to help them see the *process*,
if you believe that is where the issues lie,
and then the *real* issues and objectives.
Early focus on problem statements & goals
often leads to functionally biased solutions.

Skip to 145 –
this is not especially helpful

1 – Business process

iterate

2 – Current state

- problems or issues
- changes in context
(business environment)

3 – Future state

- goals and objectives
- regulatory mandate

A simple but more formal approach

A planned approach was out of favour for many years, but is regaining popularity:

- Identify CSFs (Critical Success Factors) for the enterprise or business area.
 - One of a small number of things that must go exceptionally well for the enterprise to meet its objectives
 - ~5, not 25!
- Rate each process' impact on each CSF in a matrix
 - 1 or little or no impact, 5 for critical impact
- Rate each process' degree of “assumed brokenness”
 - 1 if it's in good shape, 5 if it's totally broken
- Rate each process, possibly numerically
 - E.g., add up the number of CSFs seriously impacted (4 or 5) and multiply by the “brokenness”

Notes on formal process selection

What this does is identify high-impact broken processes, possibly just confirming suspicions.

(We study all high-impact processes, broken or not.)

Then, of course, can you actually *do* anything about the process? –

- Political support for change
- Natural sequence (e.g., information dependency)
- Difficulty of change (e.g., internal resistance, resources, cost, ...)
- External factors (e.g., competition, regulations, customer impact, ...)

This slide left blank to maintain balance in the universe

Encouraging change in people and organisations

1. Communicating the fundamentals of *Business Processes*
2. Identifying true, end-to-end, cross-functional *Business Processes*
3. Developing a *Process Architecture*
4. Seven ways to help people embrace *Process Change*
5. *Human-oriented* process modelling
6. A feature-based *Process Design* method –
transitioning from *as-is* to *to-be*



Seven techniques we can use to build “change” into our practice.

Origins – my clients were ahead of me



“We're using your methods as a generalised approach to *any sort of change*, not just 'process' change.”



“Do you have a degree in Organisational Psychology?”
Me : “Huh?”
“When we follow the method closely, almost slavishly, the usual resistance to change simply *doesn't materialise.*”



“Instead of Change Management at the end of a project (“Change is coming. Now CHANGE!”) we like the way support for change is built in *throughout* your approach.”

Five thoughts on what doesn't work...

1. Leaping far too quickly into specifying the future state.
No, that does not make you nimble, responsive, or agile.
2. Copying so-called “best practices” without regard for your culture, core competencies, style, or differentiator.
3. W. Edwards Deming:
“Eliminate slogans, exhortations, and targets asking for zero defects or new levels of productivity.
Such exhortations only create adversarial relationships, as the bulk of the causes of low quality and low productivity belong to the system and thus lie beyond the power of the work force.”
and
4. Failing to involve the people who actually *do* the work.
5. Client: “Everyone seems to think Change Management is a training plan.” It isn't.

Disclaimer and fine print



Not a methodology

- techniques
- frameworks
- ideas
- examples

For your awareness

So you can learn to
observe relevant factors

I'm not an expert on OD, culture, change, etc....
... but the techniques presented here *have* been validated
by experts

Seven ways to build support for change

1 – The power of venting –
let them be *heard*

2 – What first, who & how later –
abstraction to the *essence*

3 – Don't start with *why?* – the problem
with problem statements

4 – Clarify what you need to be great
at – your *differentiator*

5 – Understand *enablers* –
the levers of change

6 – Three core change techniques /
frameworks

7 – Build a feature-based, holistic
view of the future state

But if you want a method – the classic sources

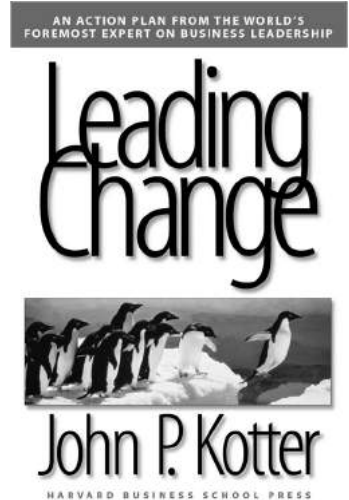
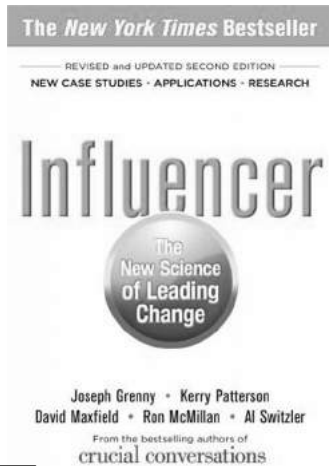

4/6 = 10x

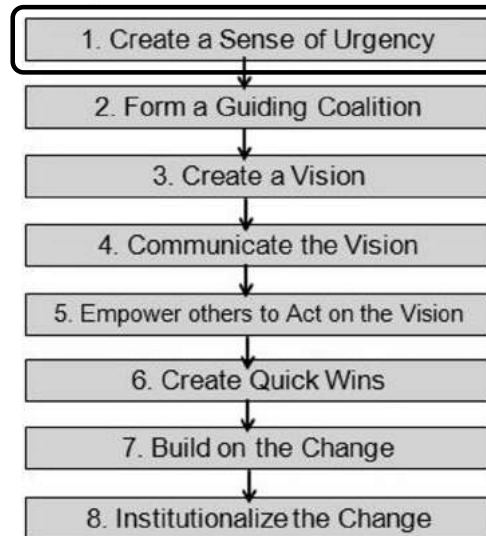

A little more from Influencer

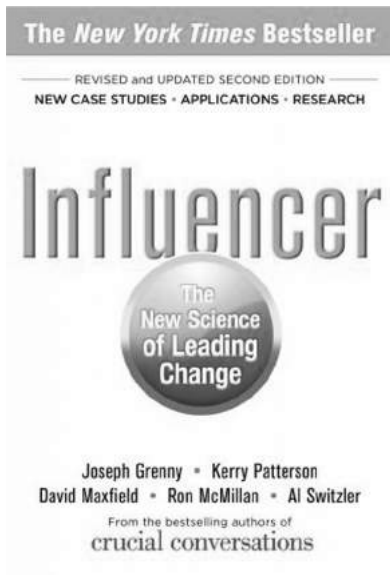

	MOTIVATION	ABILITY
PERSONAL	<p>1</p> <p><i>Personal Motivation:</i> Do they want to engage in the behavior?</p> <p>MAKE THE UNDESIRABLE, DESIRABLE</p>	<p>2</p> <p><i>Personal Ability:</i> Do they have the right skills and strengths to do the right thing?</p> <p>HELPING THEM SURPASS THEIR LIMITS</p>
SOCIAL	<p>3</p> <p><i>Social Motivation:</i> Are other people encouraging and/or discouraging behaviors?</p> <p>HARNESS PEER PRESSURE</p>	<p>4</p> <p><i>Social Ability:</i> Do others provide the help, information, and resources required at particular times?</p> <p>FIND STRENGTH IN NUMBERS</p>
STRUCTURAL	<p>5</p> <p><i>Structural Motivation:</i> Are systems rewarding the right behavior and discouraging ineffective actions?</p> <p>DESIGN REWARDS AND DEMAND ACCOUNTABILITY</p>	<p>6</p> <p><i>Structural Ability:</i> Are there systems that keep people in place and on progress?</p> <p>CHANGE THE ENVIRONMENT</p>

From Influencer: The Power to Change Anything
designed by helpinghelp.org

Address *any* four of these and your chances of success increase tenfold

1) *Venting*

1) The essence of the technique:

Early in the session, “venting” / “what's on your mind?”

- questions
- concerns
- great ideas
- what I'd change if I could

...

related to today's topic

Discussion:

- Why is “venting” an effective technique?
- What concerns do you have about “venting?”
- How would you mitigate those concerns?

A typical first session agenda

Day 1 Session Plan

Overall: 8:30_{am} - noon - session
noon - 12:45_{pm} - lunch
12:45_{pm} - 2:30_{pm} - continue session.

8:30+ Introduction by facilitator

- objectives and plan
- introductions
- ground rules

9:00 - Background and Q&A by Phil

9:30 - "Venting" - What's on your mind?
Questions, concerns, great ideas, ...
(No guarantees!)

10:15 - 15 minute break

10:30 - Individually, on large Post-its,
list ~ 7 key activities / services
your area provides. (student-facing
or otherwise)

10:50 Each unit presents, others look for synergies

Afternoon:
• somewhat TBD
• begin identifying/
suggesting activities/
services that could
be co-located in MCA

Note – establish context
before venting

Build “venting” into the session plan

Typical opening agenda...

- Quick presentation by the sponsor on scope and overall project goals (5 minutes)
- Introductions (10 minutes)
 - Facilitator
 - Participants
- Brief presentation by the facilitator (10 minutes)
 - What do we mean by “end-to-end” and what issues does this raise?
 - Key elements in defining an end-to-end view
 - Objectives for the series of sessions, objectives for today's session, and today's session plan and ground rules (5 minutes)
- **“Venting” / What's on your mind? (45 minutes)**
 - Key issues, specific expectations, concerns, burning questions, great ideas, cautionary tales, etc.
 - No guarantee they'll be addressed in this session.
- Clarify terminology (90 minutes)
- Identify significant activities (30 minutes) etc.

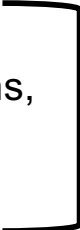

No guarantees,
strictly time-boxed

Venting example

Topic –
“Strategic Scheduling / Course Management”
(what that meant... not exactly clear)

Senior university personnel –
Department Chairs, Deans, ...

45 minutes for venting –
it was well used!

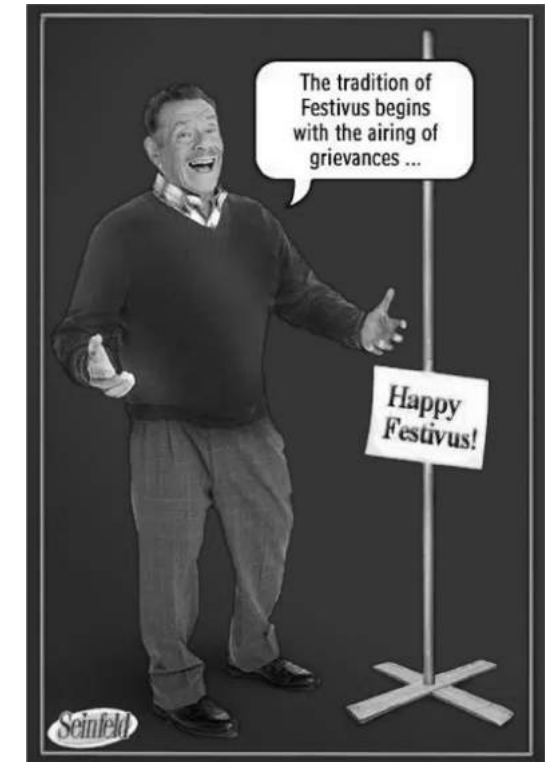
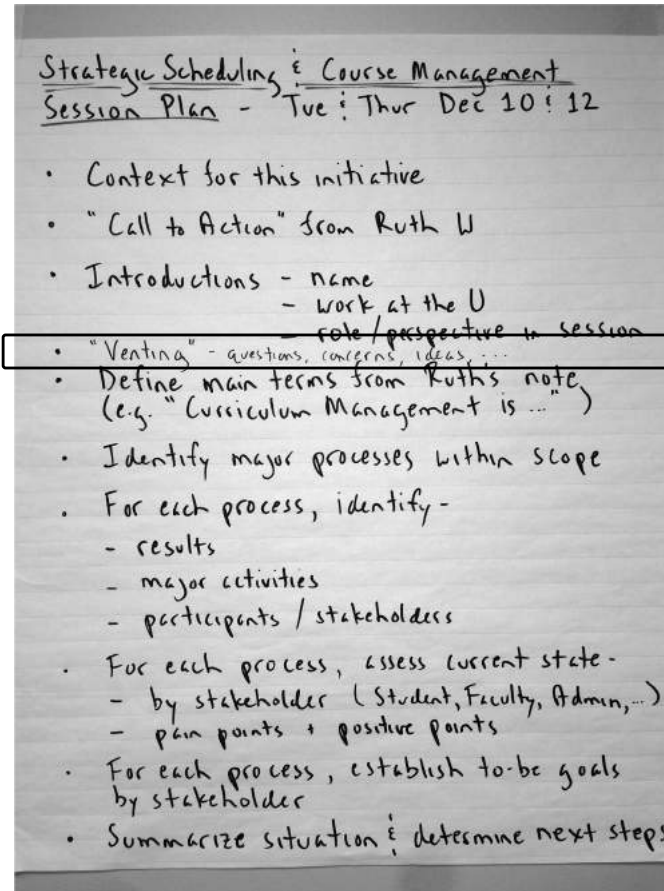

"Venting" 1 & 2

Venting - 1

- new catalog, data fields looking for data - would love to get that info. Reg'd course - how often - every semester (will be a two-way street) (how to later)
- decentralised - we make decisions in very small spaces, not so great for central view.
- figuring out history of course offering is arduous - go through archive.
- might begin enforcing ^{Science} prerequisites (huge impact cross-departmental) (Math was pioneer, then Chem, then Bi, ...)
- 2500 / 10,000 courses "inactive"
- Curriculum is rising in importance and visibility. We're challenged to forecast Delivery modes variable, student needs variable

Venting - 2

- Different depts have different ideas on delivery mode - Math has made hybrid / fully online "premium offerings"
* This has alleviated some scheduling issues.
More institutional commitment in support infrastructure would really help.
- We should define - online
- hybrid
- "offline"] *
- IT has people bring tools (point solutions) that help locally, but may impede the end-to-end process.
- Forecasting - not just four years, but more immediate. Studied students who don't pre-enrol - often availability issues. Better predictive analytics.
- * ~~the~~ But ... ~~students~~ we need to know what data students / parents are basing their "not available" statement on.

"Venting" 3 & 4

Venting-3

- the student may not have a plan, or has the plan of a peer.
- Course descriptions may be so cryptic they discourage enrollment
- Students just not aware of what's available.
- Technology has been our enemy; when you had to print a schedule, there was a lot more attention to accuracy.
- Deadlines drive us to make decisions 10-12-15 months in advance, so of course things change
- "I got a draft schedule yesterday, but don't know who will be teaching or what my budget is."
(or if there's room) - might schedule dummy classes)
- SCTH is the driver of \$ we get / don't get (and rate of growth)

Venting-4

- can't view archive schedules and see actual enrollment.
- We might not provide the options to students we say we do.
Our claims may not match our promotion.
Students can't plan because
 - we lied
 - they don't know how
 - ...
- The process of getting new courses into the curriculum takes a lot of time.
(curriculum + scheduling consume a lot of time)
- Many don't know until Senior year that they could get an Honours degree - now, is it possible.
- Innovation - how will we plan for it?
In planning, we can manage away (to avoid risk) from innovative curricular opportunities.
Plan for innovation

"Venting" 5 & 6

Venting-5

- Curriculum is the collective autobiography of the faculty, hence
2500 inactive courses,
whispering the memory of that
great prof...
- micro-issues in Business
 - 4500 undergrads means the logistics of "deconflicting" what when Acad, Fin, ... post schedules is beyond manual abilities. Need S/W tools
 - 2 year program, most students are married. Offer course once.
 - night class? Bad for parents
 - day class? Bad for working
 - tie Spring / Summer scheduling together may make more sense than tying Summer / Fall together.
 - Want to publish a guaranteed, 2 year, list.

Venting-6

- Anxious about doing something different than what we did last time - might lose a faculty
- * If you enforce prerequisites, it might negatively impact budget
- Econ has been consistent in first term / second term scheduling of core. Model has been very helpful. (need to share this innovative approach, and others.)
- Risked budget by putting in a pre-req. so we could do assessment. Also pedagogical value. Now, do we add pre-req to degree requirements. Yes, but don't know yet the impacts.
- Planning for the Student vs Faculty preferences (Tues 10:30 am (note - issues like child care impact) only)
- * Faculty have a duty to schedule for students

Two "Venting" topics raised a LOT of angst

Transfer-1

- 50% of UG across the U are transfers -
issue for students because their courses they took might not actually be equivalent, so they struggle in upper levels.
"transfer" ≠ "articulation"
↓ gen credit hrs ↓ req'd for grad fulfills a req't
- Every ^{new} course or variant generates articulation overhead.
- They choose other institutions due to
 - money ***
 - geography
 - time of day
 - class size
 - help available (remedial)

Transfer-2

*** Colleges can offer scores of sections of a course because

- low-paid faculty
- less qualified faculty

The U should promote the superior educational experience we offer, but this may not be politically acceptable.

Students are then less able to adjust to the rigors (no hand-holding) of upper division courses

quality of education accessibility of education

—————
△

- "Transfer Student" is much more varied than 2 years there, 2 years ~~at~~ here.
 - complex path
 - multiple colleges
 - did degree courses here, Gen Ed @ succ

Transfer-3

- High percentage of transfers means offering more upper level and fewer lower level - shifts focus to a two-year block.
- Transfers with an Assoc. degree often arrive from, say, SLCC without lower level req's, so they discover they are looking at 3 or 4 more years @ U.

* Need to recognise that the direction is more 1st + 2nd year students @ the U.

Two “Venting” topics raised a LOT of angst

Issue - consistency and articulation

- Different Faculty have their own syllabi etc.
State wants consistency,
Faculty wants to innovate and
tie Class to current research or
artistic work.
- consistency more important
for lower level.
- “articulation”
consistent numbering and
outcomes across USHE.
(content vs outcome)
↓ ↓
varies may vary
+ repeatability.

“Now what???!?”

Overnight, team synthesises 8 key themes

Exceedingly complex
range of issues w.r.t.
planning & scheduling
• student demographics
• transfers
• a
• process

Fell behind during
good times!

Trying to be
all things to all
people

Differentiator!

"Working in the
dark"
(lack of data
and information)

Inattention to
integrated data!

Highly
decentralized
("dis-integrated")

No "end-to-end"
view!

Reliance of
"downstream"
processes on
"upstream"
processes

Priorities!

Unanticipated
consequences

Feature-based
approach!

Structural
disincentives to
innovation

Motivation,
measurement, and
perverse incentives!

Develop Curriculum
↑
Plan Course Offerings
↑
Schedule Classes
↑
Develop Academic Plan

Architecture!

Multiple
demands on and
reliance on
Advising

The central
issue -
uncovered!

Next day, small groups expand on themes



Reaction: “Wow, we've never seen anyone actually *do* anything between sessions with our notes!”

They loved it!



The result – a gold mine!



- Active participation led to buy-in
- Uncovered the real issues before we “structured” things into a future state

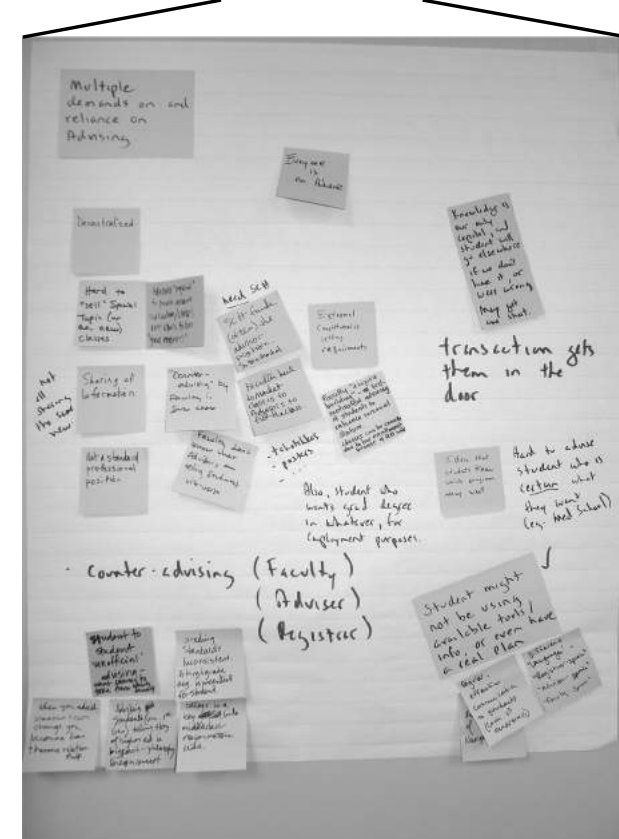

A cyclical business architecture

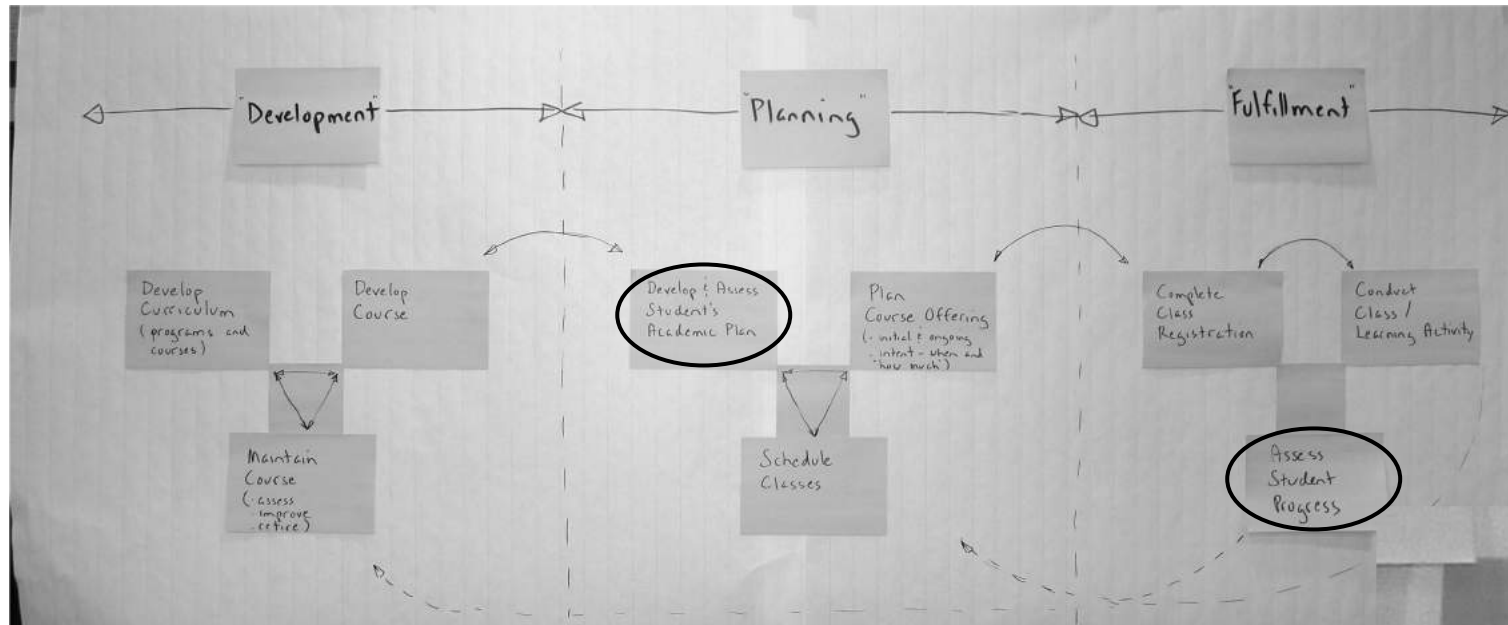

- Eventually, led to a very different Business Process Architecture and prioritisation than initially expected
- Not sure we'd have got there so quickly without “venting”

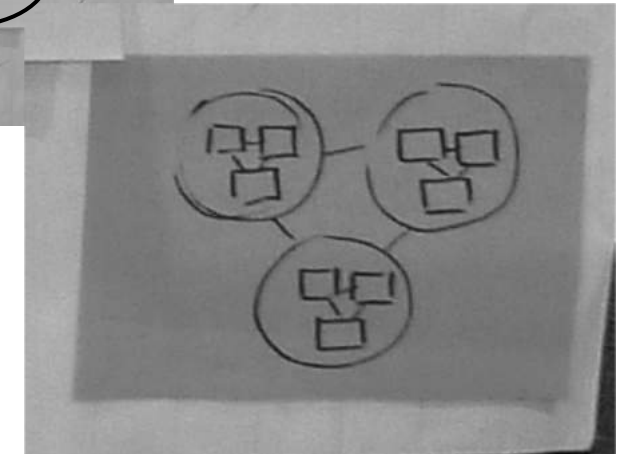

2) *What first, who & how later*

“All models are wrong, but some are useful.”



George E. P. Box
1919–2013

Two especially useful models

- Business Process Scope Model
- Business Concept Model
(a.k.a Conceptual Data Model)

Both are “essential” –
they show the essence – the
“what” – of a subject with no
reference to who, how, why, etc.

See samples on the
next two slides

Samples – Process Scope Model

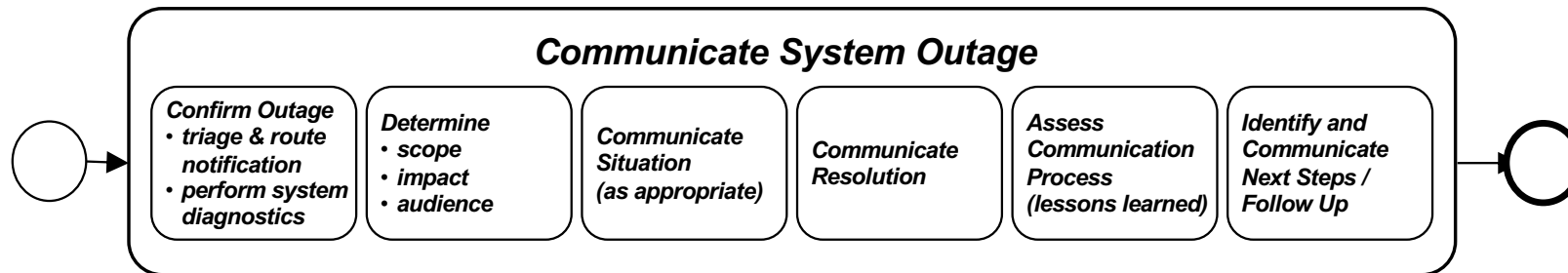

Triggering Event:

- Notification of degradation or lack of Service
- internal system
 - external provider
 - calls to Service Desk

Cases:

- new
- recurring

Other factors:

- severity
- key operations periods / areas (registration, summer, course evaluation season)
- time of year
- time of day

Results:

- Communications about the Outage and the progress on resolving it are delivered:
- internally and externally
 - informally and formally

Final Results:

- Service is restored and root cause is known (or is determined to be unknowable) and resolution is communicated:
- Externally (“good news”)
 - Internally (“cause & resolution”)

Process Scope Model using “TRAC” -
what is the Trigger, *what* are the Results,
what are the main Activities
(7 ± 2 milestones, phases, or subprocesses,) and *what* are the main cases or variations?

Why 7 ± 2?

Samples – Concept Model

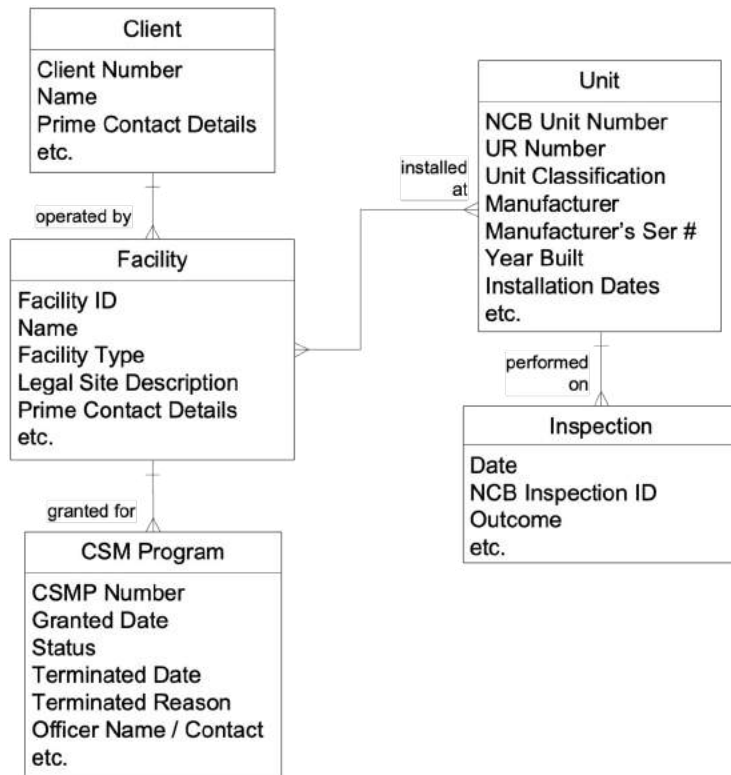

A description of a business in terms of

- **things** it needs to maintain records of – *entities*
- **facts about those things** – *relationships & attributes*
- **policies & rules** – *definitions, constraints, and assertions* governing those things and facts

“What” first, “who and how” later

Note – this won't always be appropriate, but for process- or data-focused initiatives, it's *essential!*

The essence of the technique, for process or data or both:

- Describe *what* the process is, with no reference to *who* (organisation or job role) or *how* (artifacts or implementation technology)
- Describe *what* the required data is without reference to *how* (existing systems, database/file design, forms, spreadsheets, or other implementation artifacts)

Discussion

- Why are “essential” models useful in supporting change?
- Are there any specific contributions made by Scope Models or Concept Models?

Example – evaluating S/W with data models & events

Selection of new Financials app is hopelessly bogged down

- Considerable effort in building a BDM*
- Two problems:
 - 1 matrix points to the app no one likes
 - 2 want vendor demos with focus and control

Requirements	D&B	Oracle	SAP	Coda	etc.
1	Y	Y	Y	Y	
2	Y	Y	Y	N	
3	Y	Y	Y	Y	
4	N	Y	N	Y	
5	N	N	Y	Y	
6	Y	Y	Y	Y	
7	Y	Y	Y	Y	
8	Y	Y	Y	Y	
9	Y	N	Y	N	
10	N	Y	N	Y	
11	Y	Y	Y	Y	
12	Y	Y	Y	Y	
13	Y	N	Y	Y	
14	Y	Y	N	N	
...					
...					
858	N	N	N	Y	
859	Y	Y	Y	Y	



* Big Dumb Matrix

BDM issues

- time consuming
- most apps meet most criteria
- still can't tell if an app will work well in your environment

Selecting an application

The problem:

understand business to decide on package configuration options
a list of 100s of requirements wasn't helping

The approach:

- small team builds “thing model”
(concept model, ~60 entities total, 15 “core”)
- for each core entity,
identify 3 to 5 life cycle events
- for each event, develop scenario
- turn over to app vendors - show us
 - “How do you support the data model?”
 - “How do you handle scenarios?”

“Things we track” -

Project, Work Order
Plant, Plant Equipment
Product Type, Product Lot
Product Inventory
Sale, Transfer
Location, Ledger Entity
Financial Category
Responsibility Center
Account, Sub-Account
Fixed Asset

→ *“Events that happens to them”*

Fixed Asset is
Acquired or Constructed
Depreciated
Transferred
Disposed Of

The key points:

- ***initiated by the business***
- it worked! – saw how an app would support the business
- didn't initially call it “data modelling”
- left vendor some room - “Here's how we'd do it.”

3) *Don't start with “why?”*

The essence of the technique:

After *venting and* establishing the essential *what* of the process or area being studied, conduct a three-part, stakeholder-based assessment of the as-is situation.

The three Cs:

Concerns – each stakeholder group's issues with as-is

Context – why these concerns are arising *now*

Consequence of inaction – if we don't change, what...?

Perform initial as-is assessment, determine to-be objectives

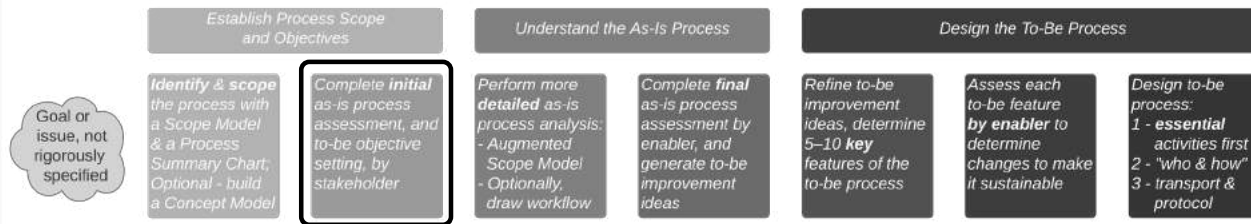

Why does this process need to change?

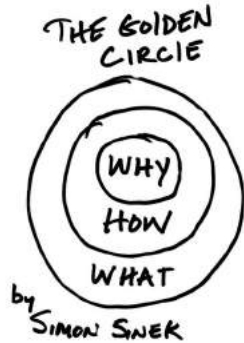
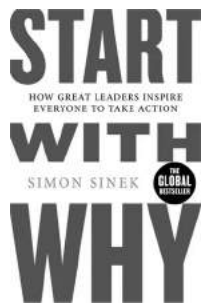

But for a process...

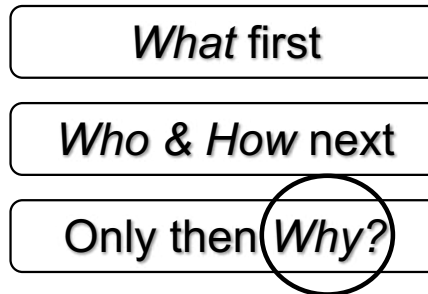

“People don’t buy *what* you do, they buy *why* you do it.”

Why does this process need to change?
We’ll answer that with a *Case for Action* (a nuanced form of problem statement)

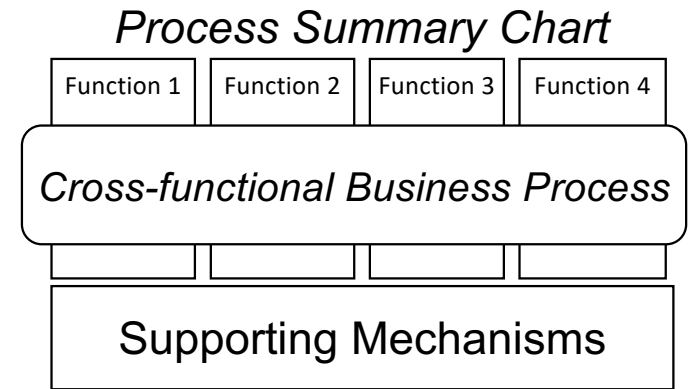
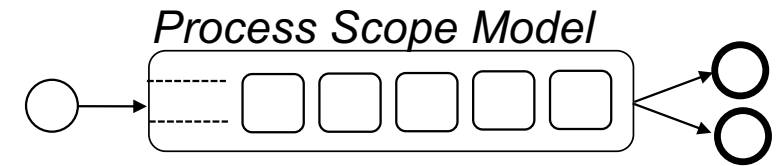

Now we have an end-to-end, cross-functional perspective.

Michael Hammer's original "Case for Action"

■ Characteristics

- a “wedge” or “prybar”; where we are, why we can't stay
- factual, not exaggerated
- concise, clear, compelling

■ Five components

1. *business context* – what's happening?
2. *business problem* – essence of concern?
3. *marketplace demands* – requirements we can't meet?
4. *diagnostics* – why we can't meet them?
5. *costs of inaction* – what if we do nothing?

- I simplified it, re-sequenced it,
and made it more stakeholder-focused

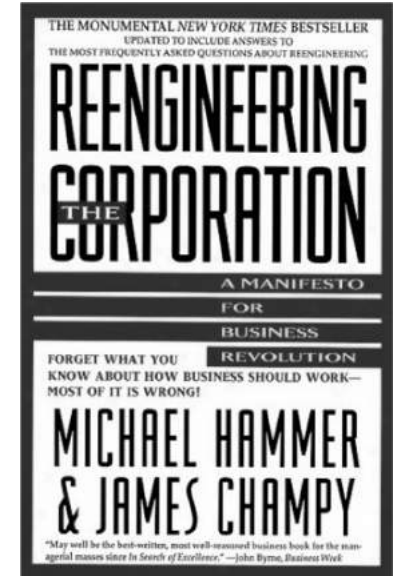

My version of Michael Hammer's "Case for Action"

Simplified, re-sequenced, more stakeholder-focussed

1) *Stakeholder assessment* – makes it *real*

What are the concerns of *each* stakeholder group?

- Customer
- **Performers** ← !
- Owner/manager (the enterprise itself)
- Others (regulator, partners, ...) as needed



*We're not
that bad!*

2) *Context* – makes it *blame-free*

What changes in the environment since the process was “designed” have caused these issues to surface?



Yay – It's not our fault!

3) *Consequences of inaction* – makes it *compelling*

What will happen if the process is left as-is?



*We'd better get on with it!*¹⁷³

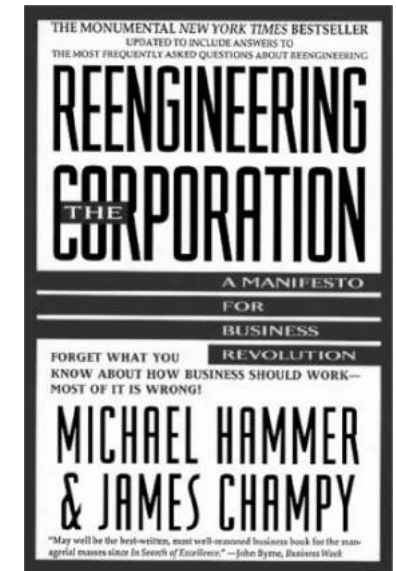

1. Stakeholder concerns

“You must communicate in a clear and compelling way why the process has to change by completing the initial assessment for the as-is process.”

Initial assessment – 3 components

Stakeholder assessment – makes it *real*

- Customer
- Performers
(*what's in it for me?*)
- Owner/manager
(the enterprise itself)
- Others, as needed

Initial assessment – typical questions

Customer:

- Are there too many interactions?
- Are rules, requirements, protocol reasonable?
- Can *your* work be located within the process?
- Are *you* the process integrator –
the human glue that connects the process steps?

Performer:

- What are your major sources of frustration?
- Do you have the necessary tools and support?
- Are there steps that serve no purpose?
- Are problems caused upstream? Does the workload vary wildly?
- What would you change if you could?
- *Is* there a documented process?

Owner/manager:

- Does the process use resources you would rather re-allocate?
- Is it a net contributor or a source of problems?
- Does the process constrain innovation, growth, or opportunities?
- Is it a source of customer or media *criticism*?

2. Context – assessing changes in the environment

Context – makes it blame-free

What changes in the environment since the process was first “designed” have caused these issues to surface?

Areas to consider:

- Regulatory change
 - Workforce changes (e.g., “recruiting and retaining” vs. “retiring”)
 - Emergent technology (AI, robotics, drones, “SMAC” - Social, Mobile, Analytics, Cloud,) or current supporting technology is EOL (“End Of Life”)
 - Changing customer expectations
 - Competition, especially new or emerging
-
- Changes in business volume (growth or contraction)
 - Socio-political change
 - Environmental (“green”) concerns
 - Change in business model (e.g., customised or standardised)
 - Change in business ownership (public, private,) M&A, divestiture
 - Change in government (post-election fallout)
 - Changes in business operating locations
 - Economic conditions
 - ... and many others (see “PESTLE”)

3. *Consequences of inaction*

Consequences of inaction – makes it compelling

*What will happen if the process is left as-is,
and the status quo is maintained?*

For the individual:

- Unsatisfying work environment?
- Diminished opportunities?
- Reduced employment
or loss of employment?

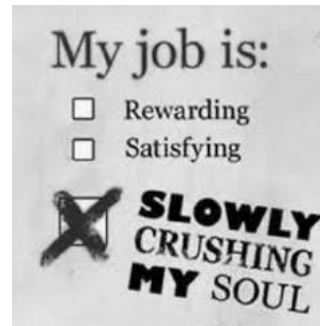

For the organisation:

- Reduced performance?
- Reduced stature or reputation?
- Withdrawal from the market?



“Case for Change” example

Situation:

- Manufacturing firm redesigns core *Financial Reporting* processes prior to COTS selection
- No progress! – Project has descended into “the blame game”

Stakeholder assessment –

- *Customer* – Financial markets / fund managers cannot get the info they need for investment decisions
- *Performers* – Finance staff spend all their time on assembling “the numbers” with no time for value-added analysis
- *Owner/manager* – CFO is under constant pressure and criticism from the financial markets and other executives

Context –

- Firm recently divested from a huge conglomerate
- Financial reporting was formerly to Head Office, but now is to financial markets which the processes were *never designed to do*

Consequences of inaction –

- Planned acquisition of competitor will not go ahead due to lack of financial market support for new bond issue;
- *Firm likely to be acquired by the competitor. Uh oh... Finance staff quickly realised their employment was threatened and got on board!*

Client was very happy!

Alec, I'm so happy I could just kiss you!



That's not in my contract

Then, establish process goals / improvement targets

“You must also provide a sense of direction by defining to-be process goals and objectives.”

Subjective goals

Give people a “*feel*” for direction:

- “Customers will love this process because...”
- “Performers will love this process because...”
- “The process owner will love this process because...”

Measurable objectives

Provide *specific targets*

Establish baseline to *prove success*

Format:

- Topic
(what will be improved?)
- Target
(what is the measurable objective?)
- Timeframe
(when will these results be realised?)



It may now be appropriate to consider new process measures, metrics, and key performance indicators (KPIs,) and establish baseline performance

Example from in-person workshop – assessment to goals

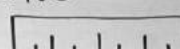
Stakeholder-based Initial Assessment of the as-is. ("Case for Action")		Stakeholder-based goals for the to-be	
		Subjective 	Objective 
		"Why will they 'love' the new process?"	"measurable" topic / target / timeframe
1) Stakeholder concerns	<u>Customer</u> : · excessively "high touch" (too many meetings) · long lead times from contact to publication · errors in ads and invoices	→ fewer or no meetings	→ ads approved at first review / 80% / Q4 2017
		→ shorter lead time	→ lead time / reduced from average of 10 days to 5 / Q4 2017
		→ no errors in ads or invoices	→ invoice error rate / .3% / Q4 2017
	<u>Performers</u> : <u>Sales Rep</u> : · too many review meetings which cut into selling time · overhead ("administrivia") in order submission procedure	→ fewer or no meetings	→ ad orders / week / +20% / Q1 2018 (or commission?)
		→ relief from burdensome order submission	→ time spent on order submission / -% / Q4 2017
	<u>Production</u> : · Monday to Wednesday Crunch · too many cycles to obtain ad approval	→ level workload	→ daily workload / variation / ≤ 5% / daily / Q4 2017
		→ more ads approved on first review	→ ads approved at first review / 80% / Q4 2017
	<u>Finance</u> : · redundant ad order data leading to errors · lack of pricing controls	→ elimination of ad order data redundancy ("single source of truth")	→ ~
	<u>Owner</u> : · ceiling on growth · lost revenue · staff frustration	→ GROWTH	→ page count / increasing at 15% per annum / Q1 2018
		→ no lost revenue to excess	
	→ eliminate stress and friction	→ staff satisfaction score / ? / Q1 2018	
2) Context: growth, customer expectations, IT, competition			
3) Consequences of inaction: Out of business!			

Case for Action summary

Stakeholder assessment

All stakeholders have *real* issues with the as-is process – it needs attention!

Factual and unexaggerated

Context

These issues have surfaced because of changes *beyond our control* in the wider environment.

Blame-free and non-threatening

Consequences of inaction

If we don't fix this process, there are *serious* consequences – individually and for the enterprise.

Urgent!

The *Case for Action* is also a great starting point for specifying to-be objectives, and clarifying the process' *Differentiator*.

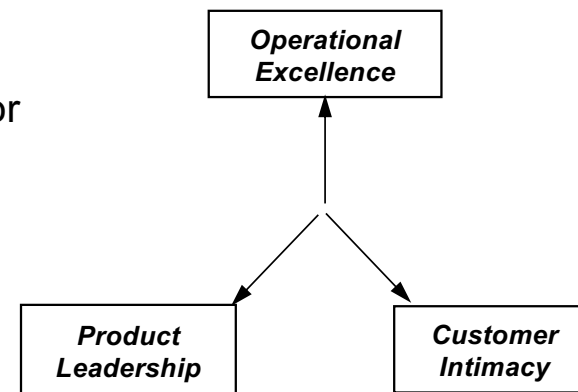

4) Clarify the “differentiator” – how will you excel? (a reminder)

*Great at one,
good at the other two.
(Not awful at the other two.)*

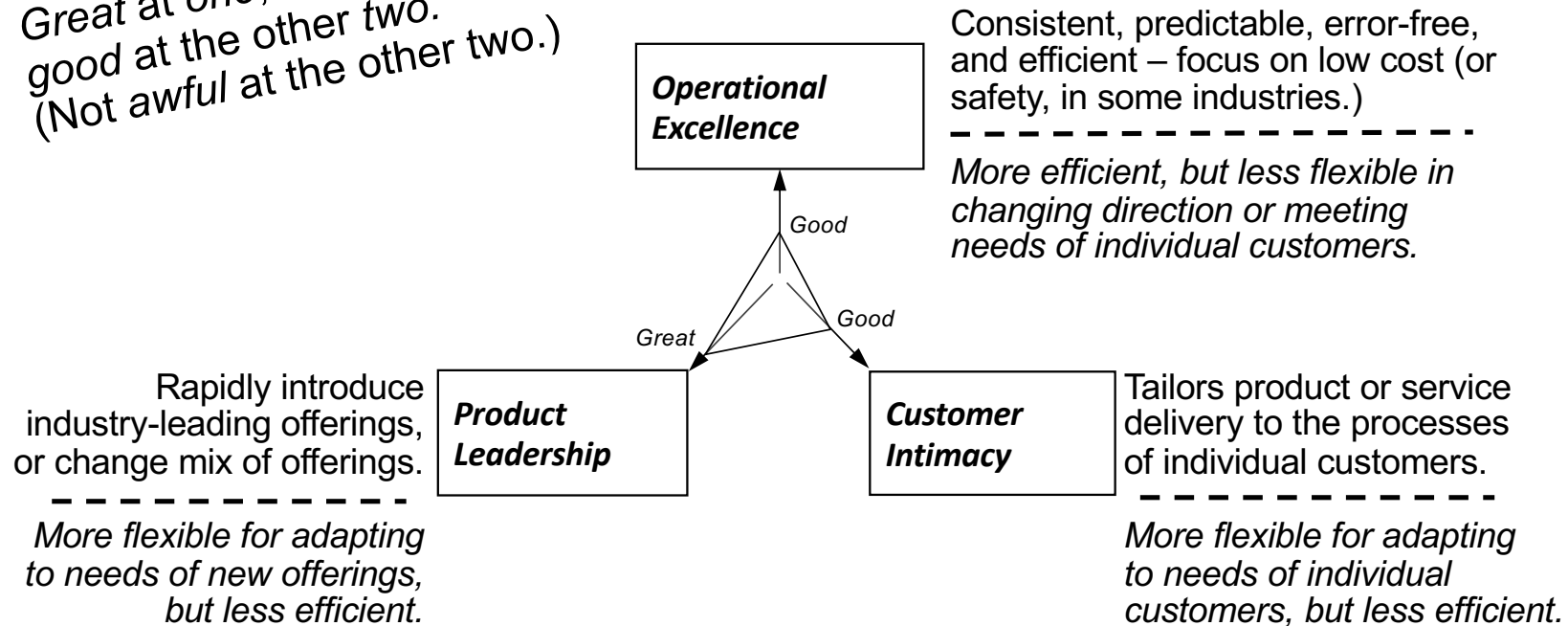

Failure to focus on *one* differentiator – *lower performance*

Focus on the *wrong* differentiator – *customer alienation*

Conflicting differentiators – *stressed workforce, lower performance*

You must understand the differentiator for your to-be process

- “*Differentiator*: “Why choose us?” or “Why would someone choose our process, even if there is no alternative?”
- Market leaders choose one, and build around it
e.g., low-cost shipment vs. guaranteed overnight delivery
- A “signpost” for decisions on process changes

	Strategic Disciplines		
	Operational Excellence	Product Leadership	Customer Intimacy
Core business processes that...	Sharpen distribution systems and provide no-hassle service	Nurture ideas, translate them into products, and market them skillfully	Provide solutions and help Customers run their businesses
Structure that...	Has strong, central authority and a finite level of empowerment	Acts in an ad hoc, organic, loosely knit, and ever-changing way	Pushes empowerment close to the point of Customer contact
Management systems that...	Maintain standard operating procedures	Reward individuals' innovative capacity and new product successes	Measures the cost of providing service and of maintaining Customer loyalty
Culture that...	Acts predictably and believes “one size fits all”	Experiments and thinks “out-of-the-box”	Is flexible and thinks “have it your way”

Understanding through differentiators

The first time I used this framework on a consulting engagement.

Leading U.S. HMO
(Health Maintenance Organization)

- Reengineering (*major* change) of “Provide Clinical Care” is stalled
- I'm brought in to get it moving

Key finding when determining objectives of program:

- 50% thought Op Ex
- 50% thought C.I.

The immediate outcome...

The ultimate outcome...

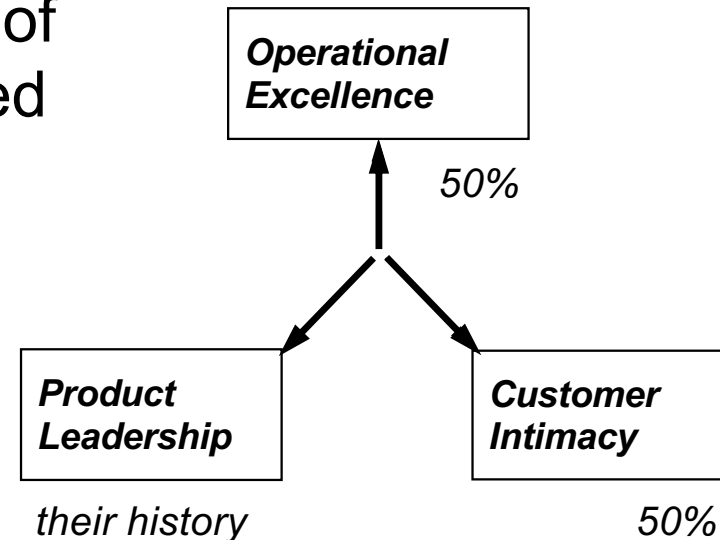

Failure from not considering differentiator

Recent example of serious failure due to mishandling differentiator change

Global leader in high tech field, massive growth

- New COO +
Sr. VP Global Process Design
- The goal – *transform the business!*
- What they were really (unwittingly) doing –
moving from PL to OpEx
- HR consequences:
a huge shift in *values*
- Staff reaction: *intensely* negative
- Consequences for “process” ...

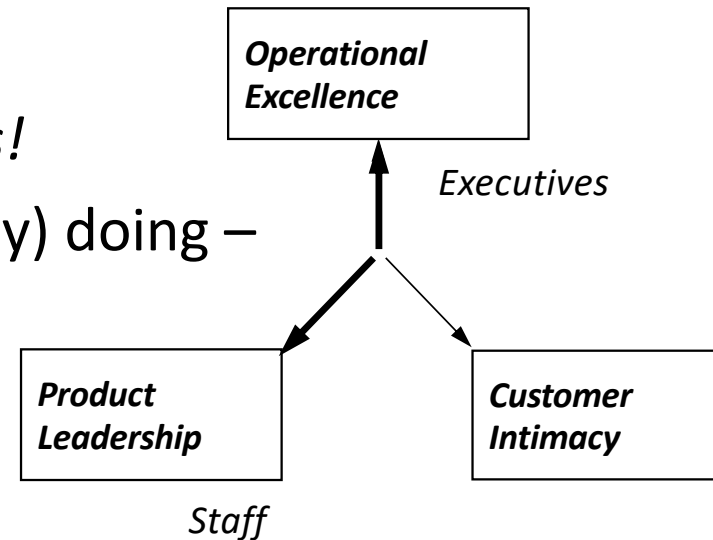

Another example – different differentiators

Client: a financial services organisation offering the management of tax-advantaged savings for higher education was a recent assignment.

- We'll call them “EdSave.”
- Terrific growth, now things “fraying around the edges,”
M.D. requested an “organisational review.”

Outline of our findings:

- Background, approach, observations, quick wins

- Mission and differentiator

- The organisation overall:

Leadership and management, high-level structure, recruiting and retention

- The organisation's culture:

Communication, management style, writing & review

Later, in the section on
organisational culture

- Cross-functional work and projects
- Organizational role refinement – Operations and Finance
- IT: Custom system (The “Windows app”,) outsourced development,
IT role refinement
- Business Intelligence / Analytics

EdSave differentiators

“EdSave” is a classic example of an enterprise in which two different business areas – development and execution – each have their own differentiator

In *developing new offerings*, the differentiator is clearly *Product Leadership*

- EdSave known as the innovator
- New product development partly contracted out to external financial consultants
- “We must constantly innovate, because if the ratings fall, money *moves*.”

In *serving the Account Owners* (opening, contributions, withdrawals, ...)

EdSave's differentiator must be *Operational Excellence*

- To drive the cost structure down, EdSave must continue to drive Account Owners to an easy-to-use web experience and minimize person-to-person interaction
- “*The Boglehead mentality focuses on fees, fees, fees.*”
- “<EdSave offers> *a simple plan for simple people to engage in a solid plan.*”
- “*We must make a concerted effort to minimize complexity*”

Vision – what is EdSave's “differentiator?”

2) Operationally, EdSave must “execute like crazy”

- low costs lead to low fees
- understandable offerings and processes

EdSave's differentiator is not *Customer Intimacy*, and should not be distracted by it

- The most common error organizations make is trying to excel at Op Ex and CI
- “Do we really need to respond to that one cranky customer?”
- “One comment from an Account Holder has us trying to turn on a dime.”

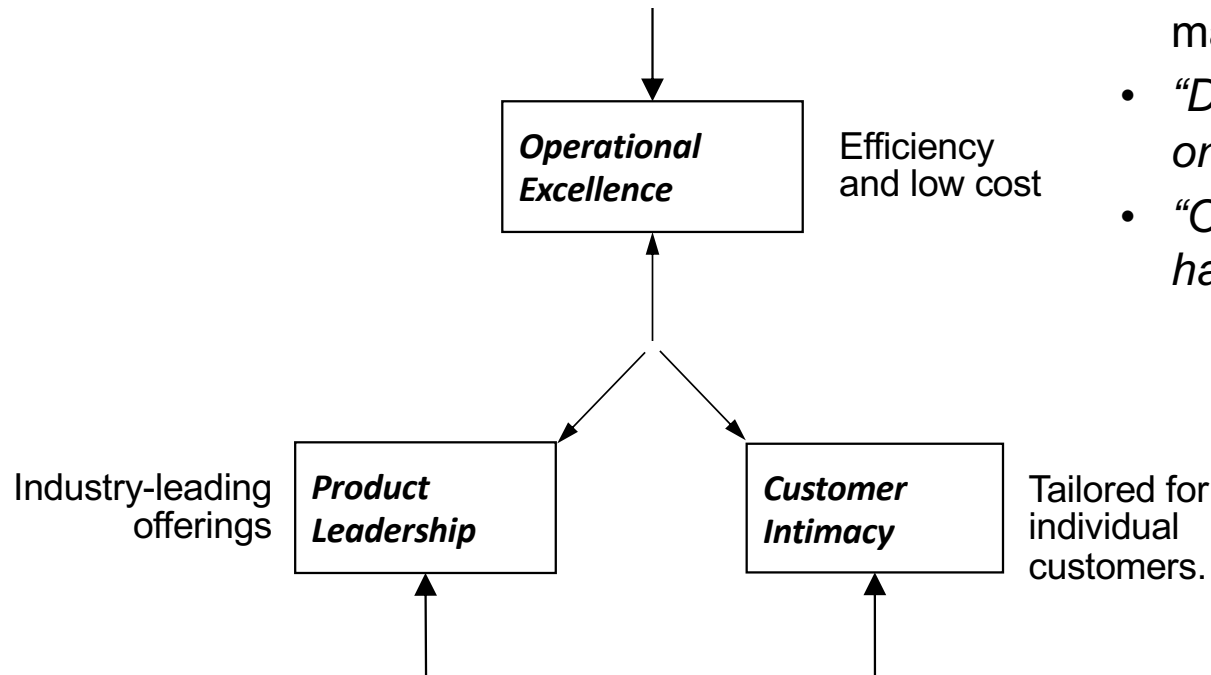

1) EdSave creates leading products

- consistently first with new options
- partially subcontracted out

Don't get distracted by tailoring for individual customer needs

5) *Understand the enablers of performance*

The essence of the technique is to explicitly consider the as-is and the to-be with respect to each enabler, forcing a *holistic* view.

How well or how poorly a process performs is determined by six factors referred to as “the enablers of a process.”

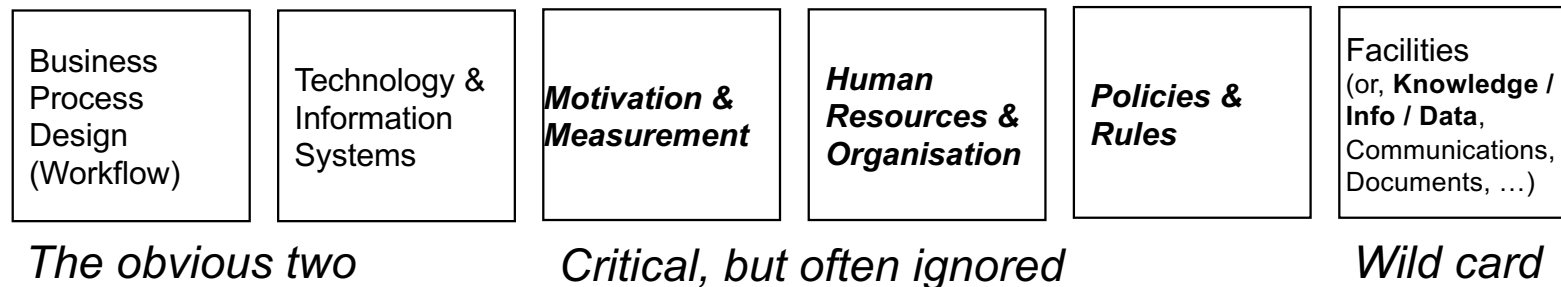

Many clients use this framework to think through *any* sort of initiative

After as-is modelling, assess process by all enablers

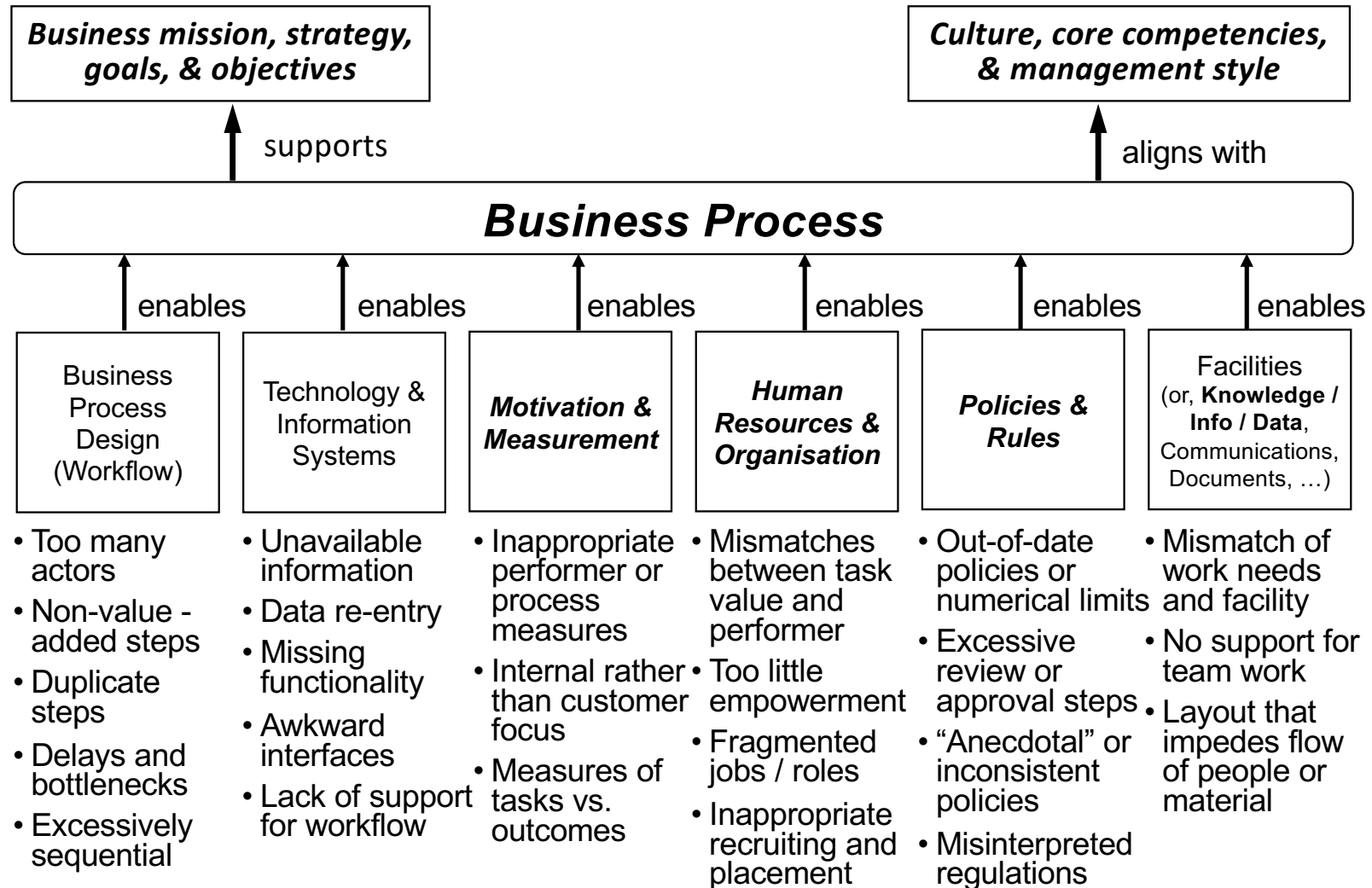

Examples – enablers becoming disablers...

Process Design	The as-is Insurance Claims handling processes were highly sequential, involving multiple participants and many NVA tracking and checking steps. The to-be process perfectly duplicated the as-is flow using a workflow engine!
Information Systems & Technology	Nurses in a Regional Dialysis Program were “supported” by multiple, dis-integrated applications, some externally hosted. Staff spent >50% of their work hours manually copying or “cut and pasting” data between applications.
Motivation & Measurement	A major telephone company invested hugely in reengineering Customer Service processes to enable CSRs to up- and cross-sell, but left performance measures based on call time in place, which ultimately caused total failure.
Human Resources	Like many large organisations, a Forensic Sciences Lab had undergone cost-cutting, and laid off many administrative support workers. Much more highly paid, scarce scientists then spent ~55% of their time on admin tasks.
Policies & Rules	A Property and Casualty Insurer required a document be signed at a broker's office and sent to a central verification unit for any policy change. The company is now global, and this is now a major bottleneck of dubious value.
Facilities (or other)	As a strange outcome of a merger, a Contract Electronics Manufacturer's QA facility was remote from their main manufacturing site. Moving goods back and forth to the QA facility actually introduced additional defects.

“Motivation and Measurement” enabler is crucial

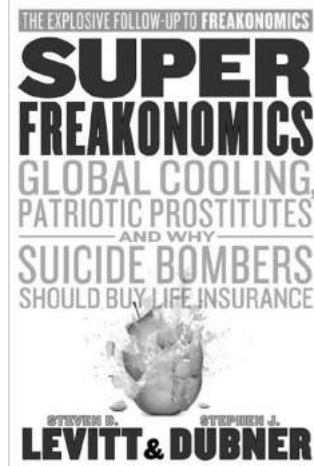

In the introduction to Levitt and Dubner's latest...

“Was there a theme to Freakonomics?”

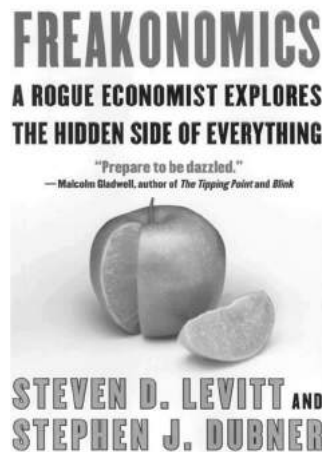

“...the book did have a unifying theme, even if it wasn't obvious at the time, even to us.”

*“People respond to incentives, although not necessarily in ways that are predictable or manifest. Therefore, one of the most powerful laws in the universe is the **law of unintended consequences.**”*

Are “unintended consequences” unavoidable?



“What we've got here is a failure to anticipate...”

*“Unintended consequences”
are often simply a failure to anticipate
what is obvious in hindsight.*

*It helps to remember that
“what you reward is what you get” and
“what gets measured is what gets done.”*

Looking for ~~trouble~~ consequences

At a Financial Services company,
important activities were seen as separate processes,
each with their own measures of success:



Measured on
number of
prospects
generated



Measured on
contacting all
prospects



Measured for long-
term viability of
client

*What consequences
would you expect from
the measures of the first
two processes?*

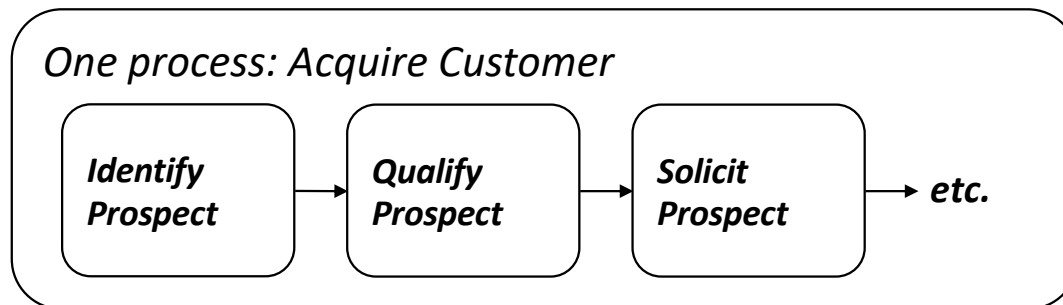

Measured on
quality of
prospects

Measured on
identifying
“good fit”
prospects

Smaller number of prospects, more
time to tailor solicitation, higher
conversion rate

*Process sequence and
metrics support sales
funnel.*

6) *Three core change techniques / frameworks*

1 – Force Field Analysis – what's working for and against your change efforts?



2 – Beliefs – are your organisation's beliefs preventing it from moving in the direction it needs / wants to go?



3 – Organisational Culture – is your organisation's culture at odds with where you need to go?



1 – One-pager on “Force Field Analysis”

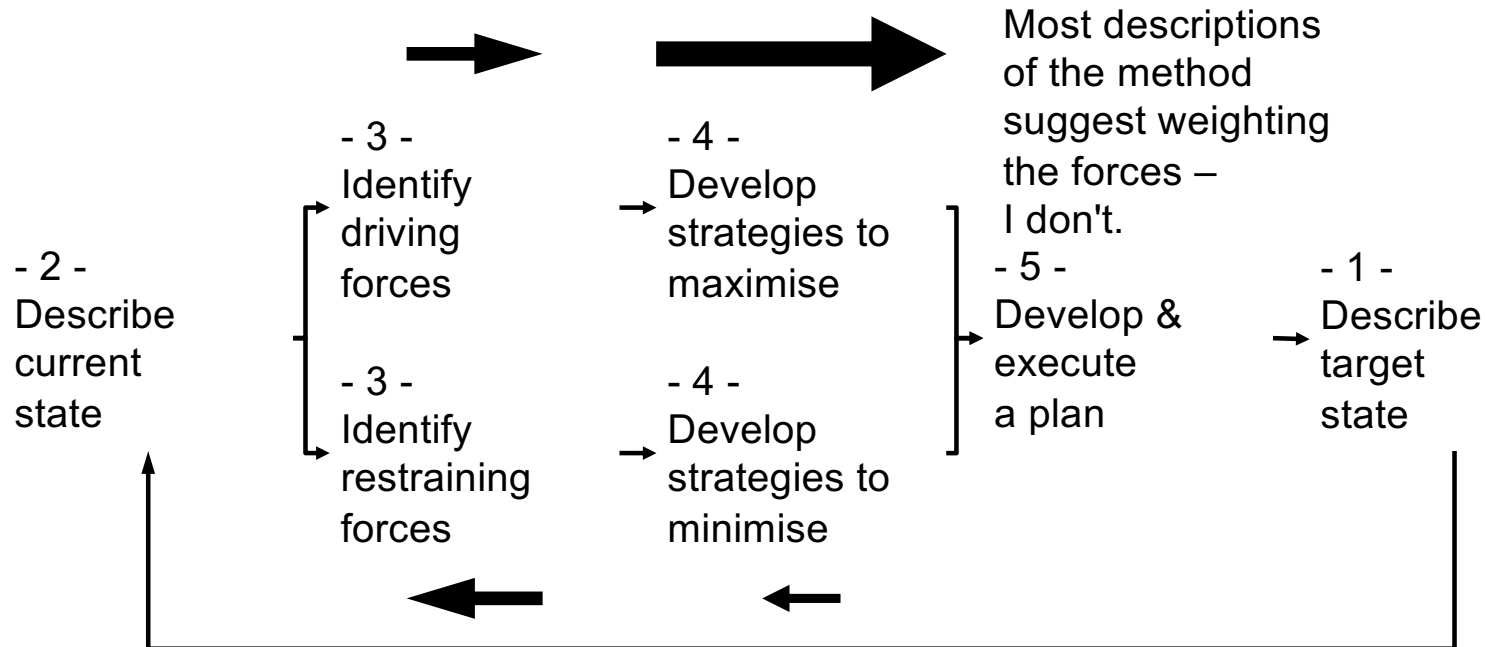

A method to list, discuss, and assess the various forces for and against a proposed change;
 Developed by Kurt Lewin;
 Originally for Social Science, now widely used for all sorts of change.

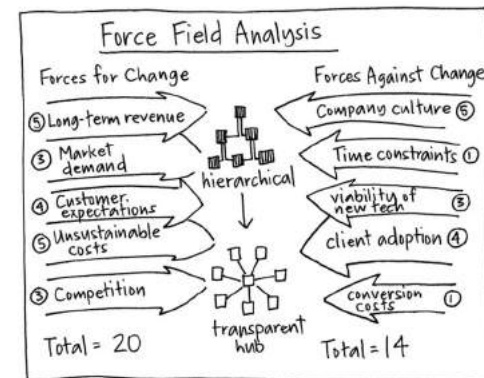

Well... maybe a second page

Force Field Analysis can make the situation visible in short order...

Resistors – 5

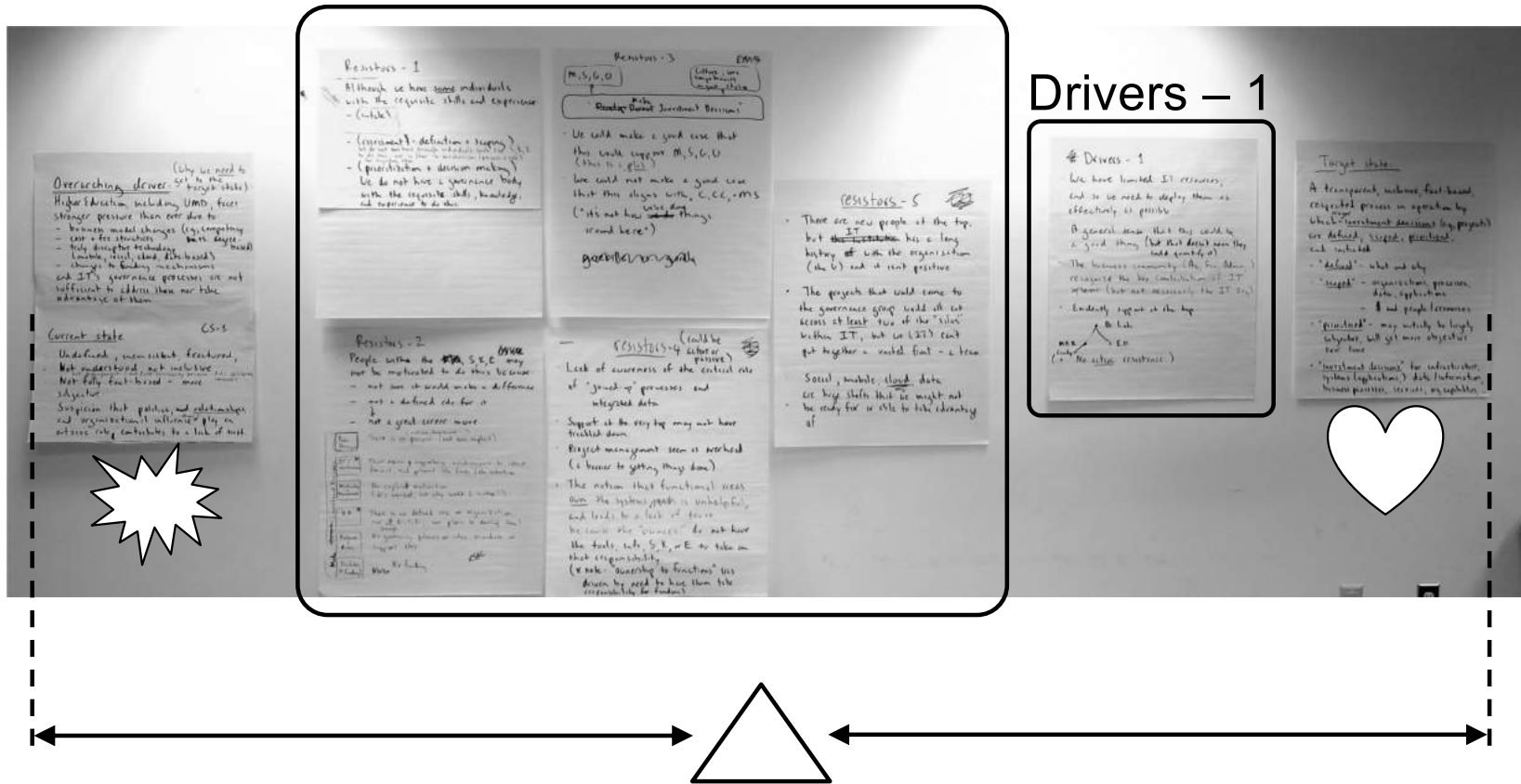

2 – Organisational beliefs, and their impact

The essence of the technique is to identify the underlying (and often unstated) *beliefs* that drive the behaviour of the organisation – the *paradigms*.

E.g.,

- Belief –
"Our Customers expect a *high-touch* experience with *personal contact*."
- Reality –
"Our younger Customers want a *low-touch* experience via an *app*."

Then, are these beliefs preventing the organisation from moving in the direction it needs to go?

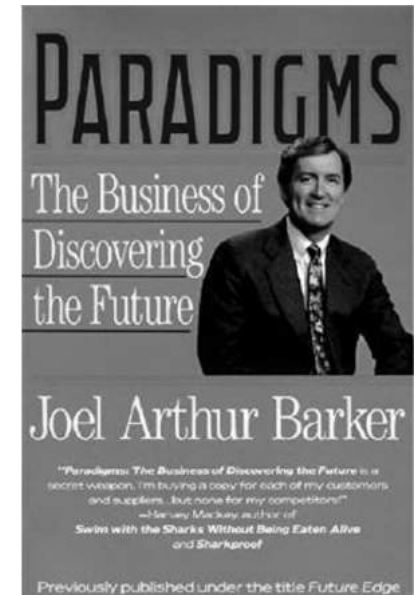

Case study – belief systems as barriers

The Problem:

Leading high-tech manufacturer hits limits to growth – they can *build*, but can't seem to *ship* complete systems

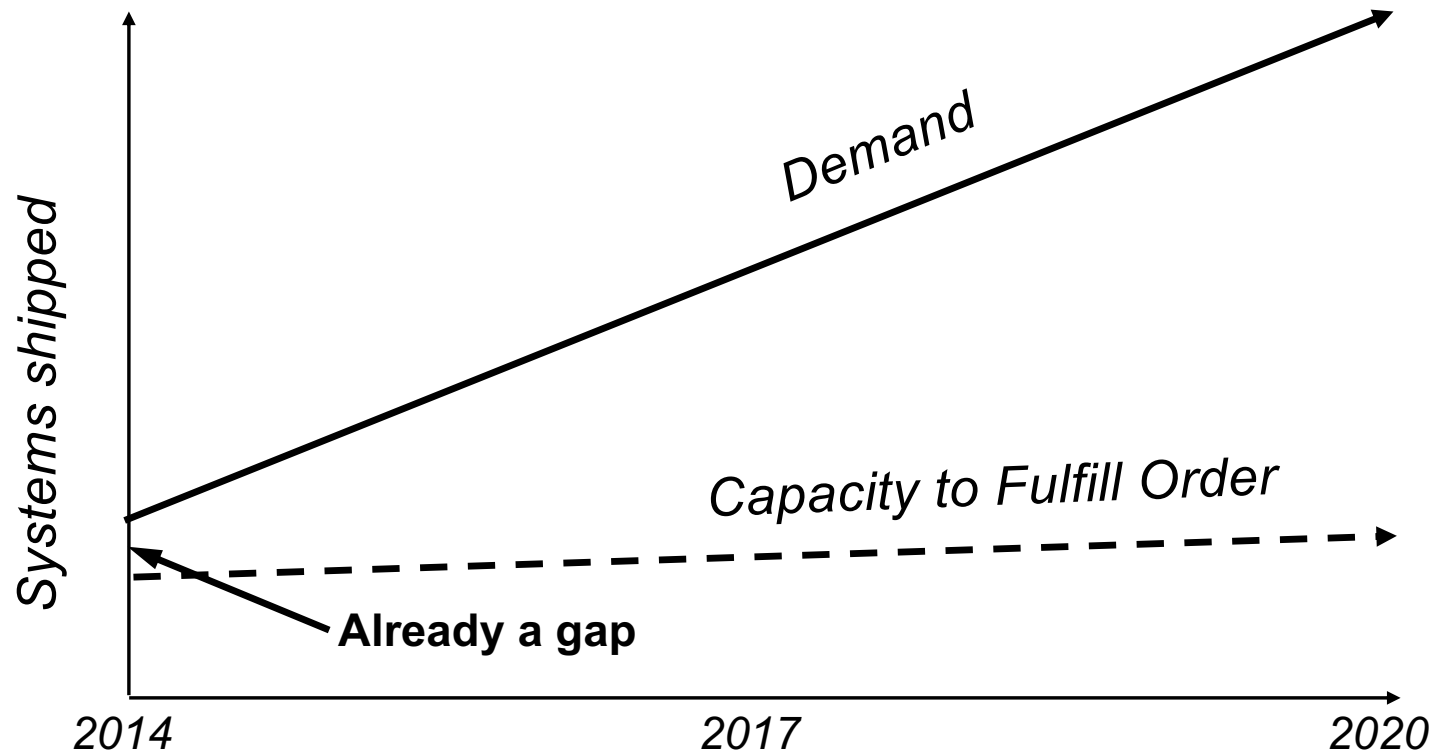

What works for a \$100M company doesn't work for a \$1B company!

Hitting the wall of beliefs

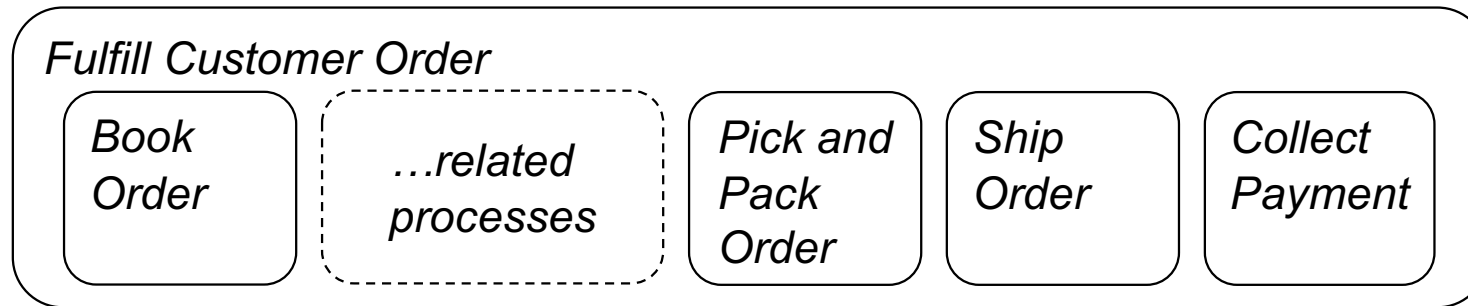

Determined root causes and suggested process changes.

But, for every suggested change: **“We can't do that!”**

The Third Law of Process Design: *“For every suggestion, there is an equal and opposite reason it can't be done.”*

Team visibly dispirited: “This is the point we always get to!”

Me: “Always...?” Team: “This is the fifth time we've tried!”

Classic symptom of having “hit the limit” with underlying beliefs

*To achieve more than incremental improvement,
a new platform of beliefs and principles is needed.*

Formulate value statements – new beliefs

First, identify barriers, the underlying beliefs causing them, then *new beliefs*

“We value this...”	“We value this more...”
Adapting schedules and dates to meet customer requests.	Providing a firm Promise Date to the customer, and sticking to it
Capacity utilisation of a cell or a person.	Smooth, non-disrupted flow of the overall process and the well-being of associates.
Responsive teams.	Recognizing that teams have a real lead time and capacity.
Teams value their data	One visible source of the truth
<i>Filling Consumable Orders within 24 hours and minimising finished goods inventory. (This was the core issue!)</i>	<i>Shipping complete system orders according to Promise Date and not “cannibalising” them.</i>

Borrowing from
The Agile Manifesto

This simple but cohesive set of value statements enabled us to describe a new process.

Collect ideas. Lots of ideas...

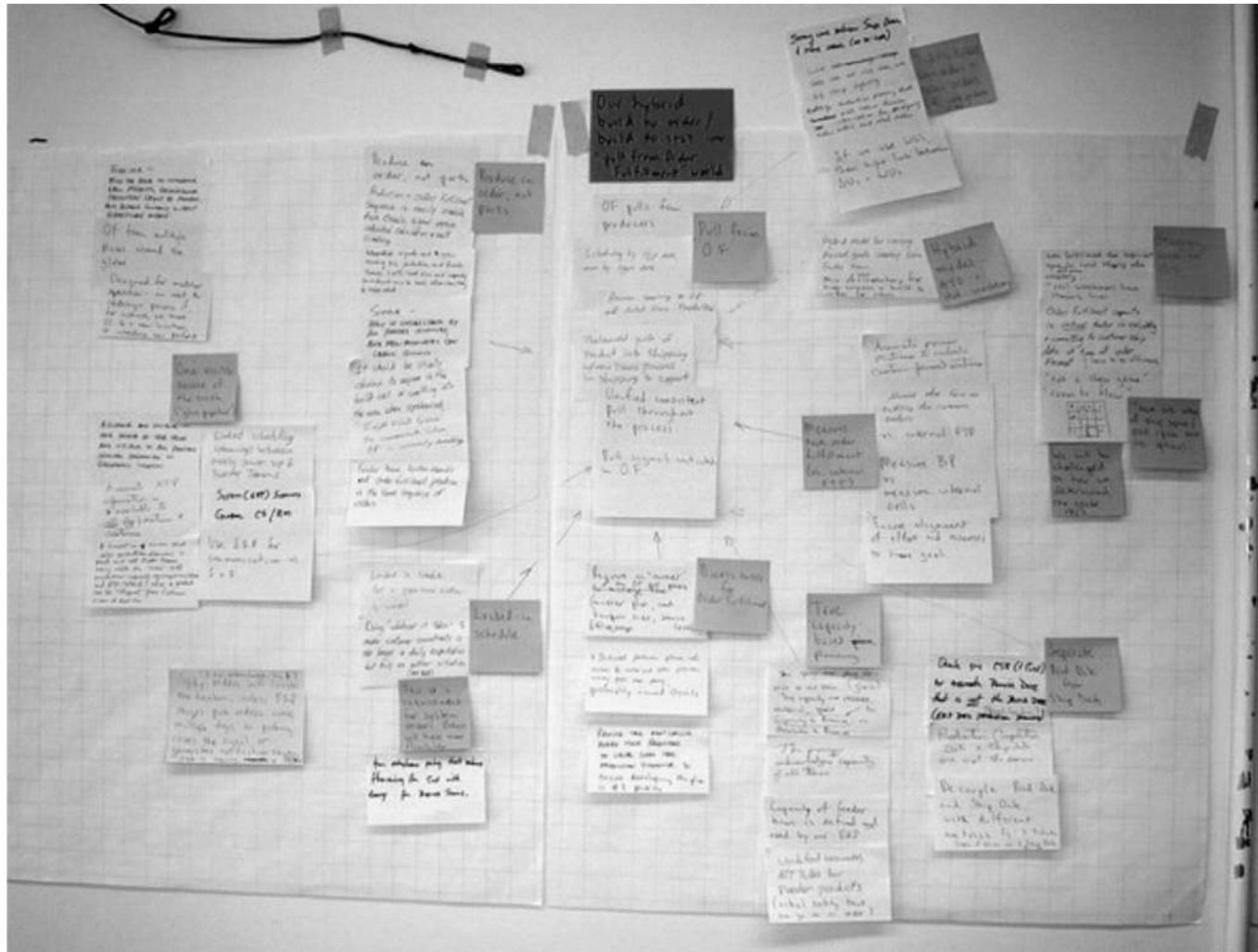

Identify 5 to 10 key features of to-be process

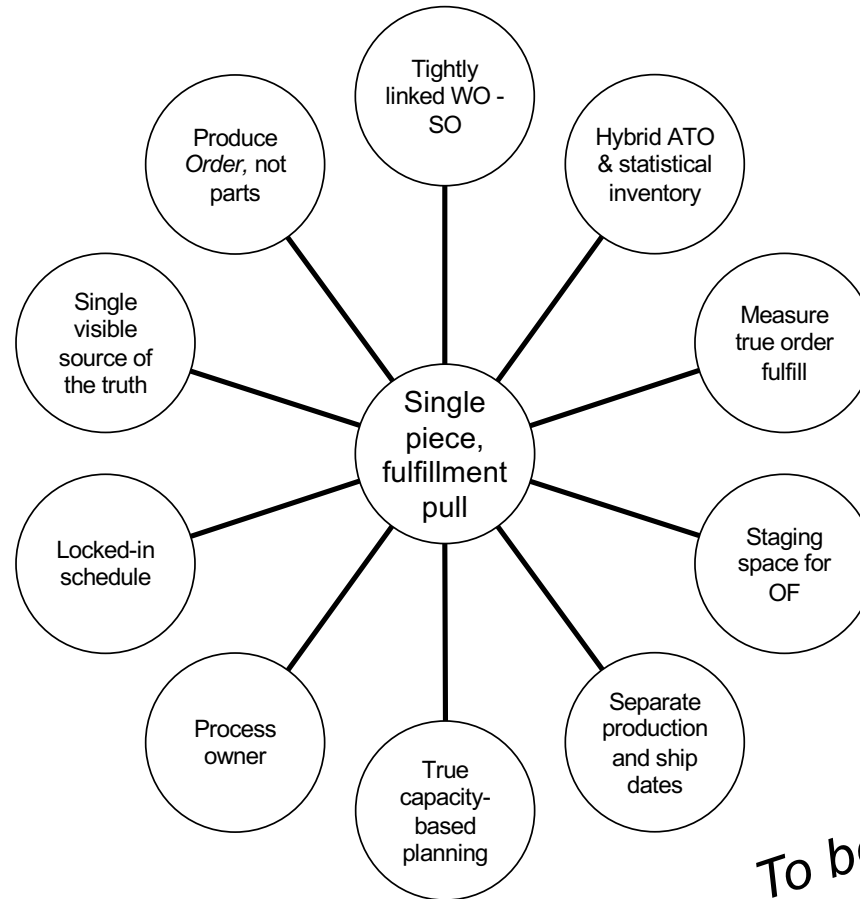

To be continued...

Fulfillment-pull model

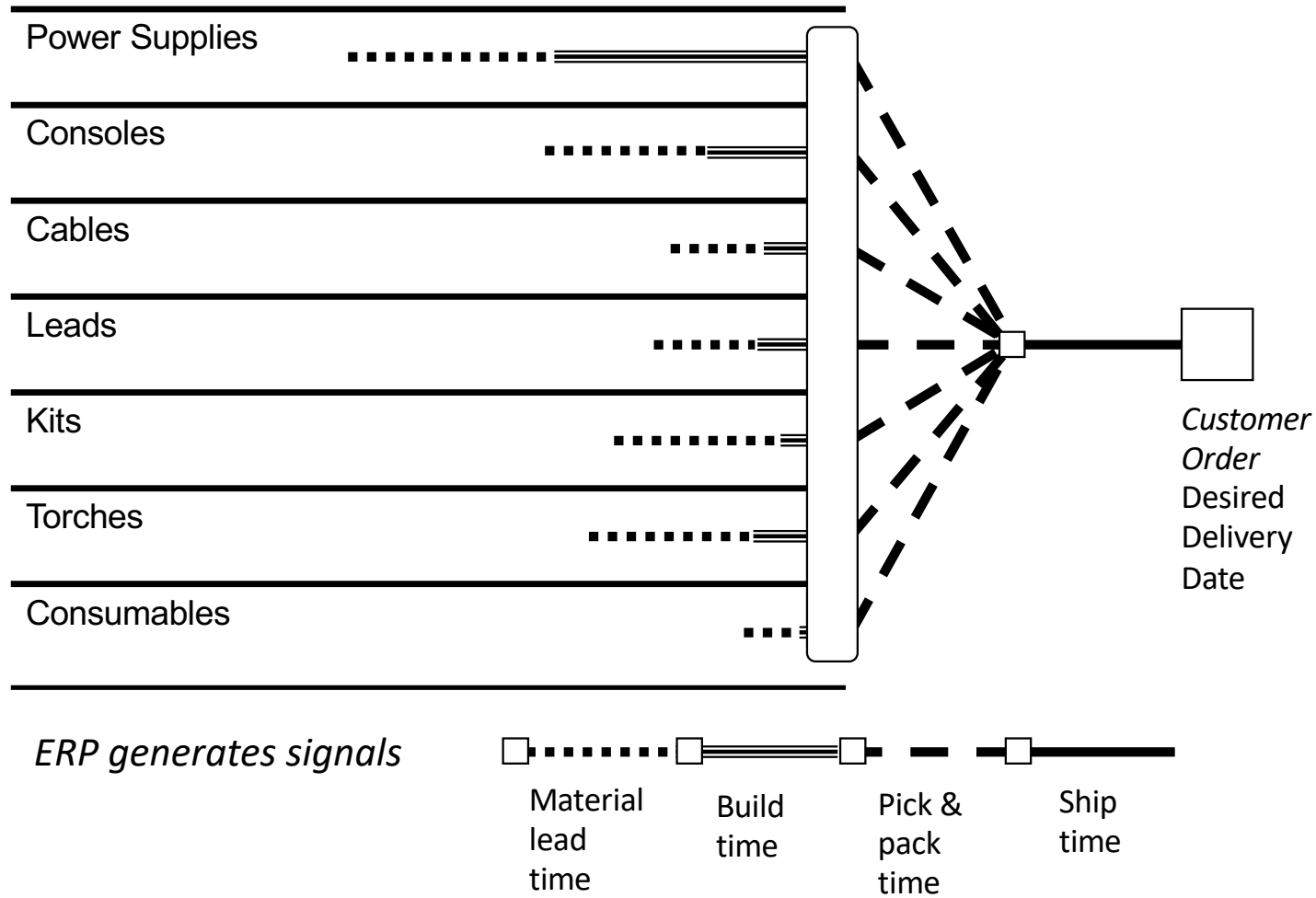

Reporting it out to the CxOs

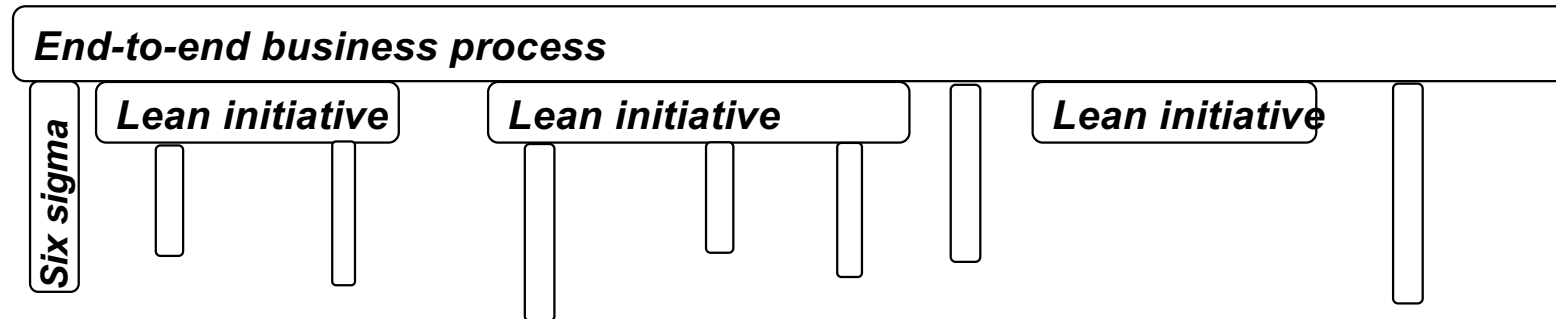
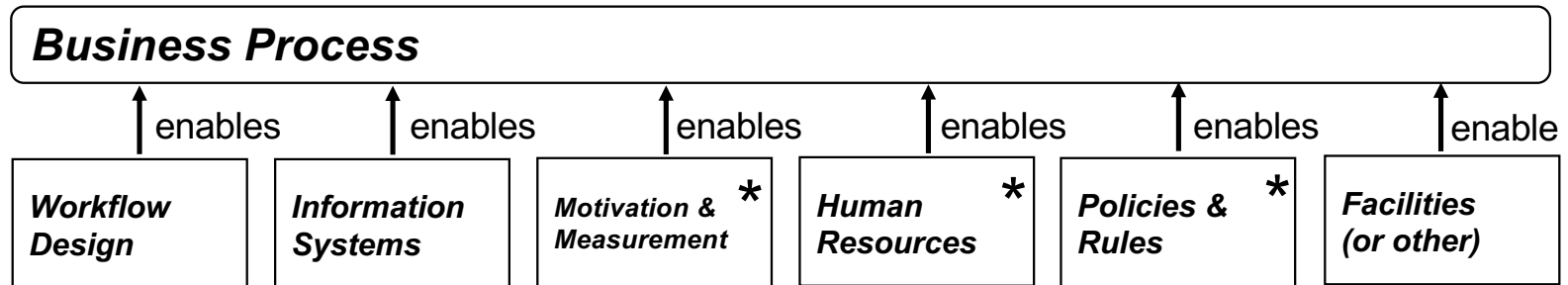
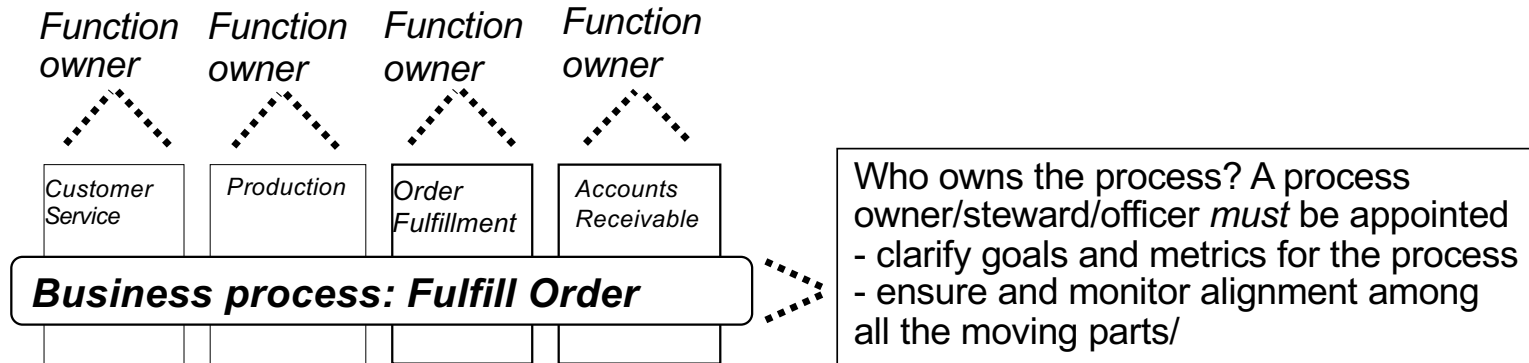

3 – Organisational Culture summary

Culture: behavioural norms that are reinforced because they are seen as “good.”

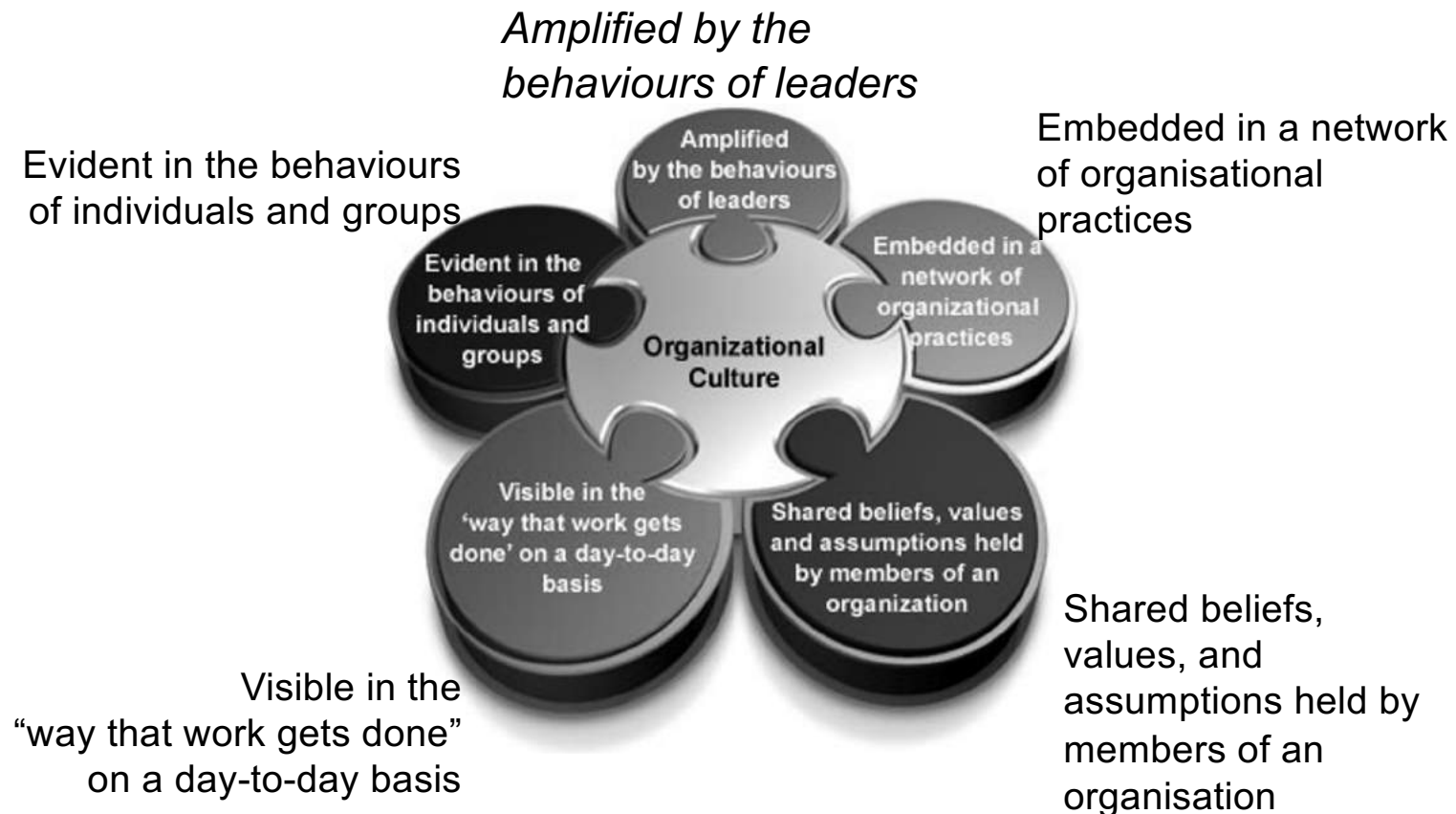

Summary image from <http://www.nhorizons.ca/>

Note – "What is good?" may vary across functions

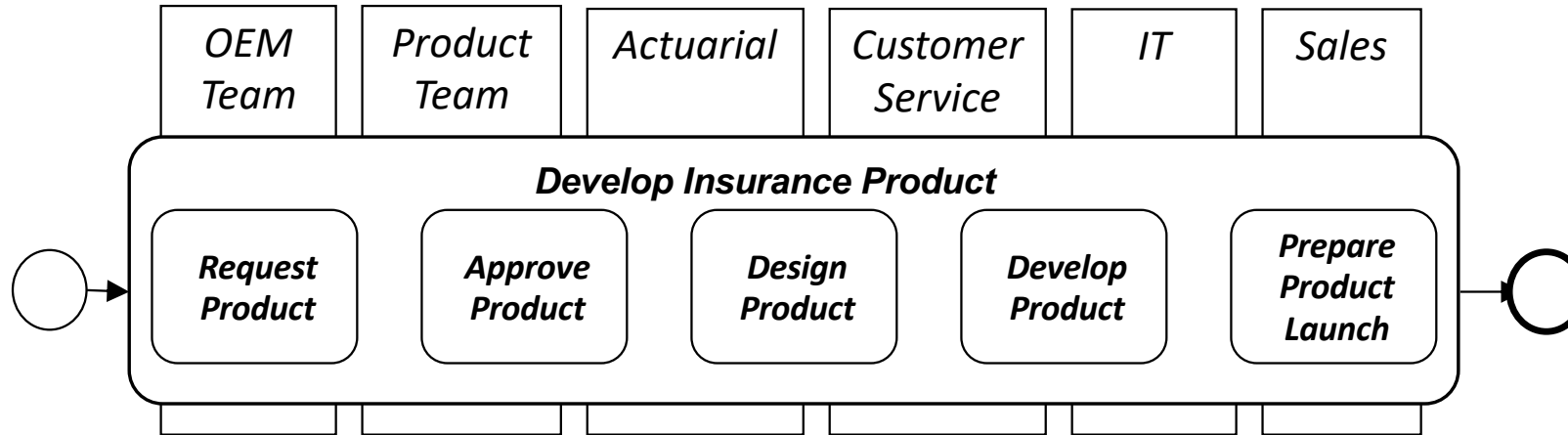

The misalignment might not be in explicit measures, but in different groups' perceptions of “what is good”

- OEM – deadline driven
- Product – number of products / features introduced
- Customer Service – simpler products
- IT – bug-free product launches

Organisational Culture

- 1) Assess “organisational culture,” formally or informally, using one of the available frameworks –
we'll use the Organisational Culture Assessment Instrument (OCAI.)
All organisations have a culture, recognised or not.
Impacts process design and ability to change e.g.,
an organisation characterised by
centralised, top-down control and decision making
will not successfully implement a change requiring
front line accountability and decision making
What is a *best practice* for one culture can be a *worst practice* for another

- 2) Considerations
A quick, informal assessment is probably adequate
You might keep your assessment to yourself...

Organisational culture

OCAI – Organisational Culture Assessment Instrument

Professors Kim Cameron and Robert Quinn found two dimensions of culture were vital in understanding effectiveness:

- *Internal* focus and integration
vs.
- *External* focus and differentiation

- *Stability* and control
vs.
- *Flexibility* and discretion

A survey-based assessment determines

- *current* dominant organisational or team culture
- *desired* organisational or team culture

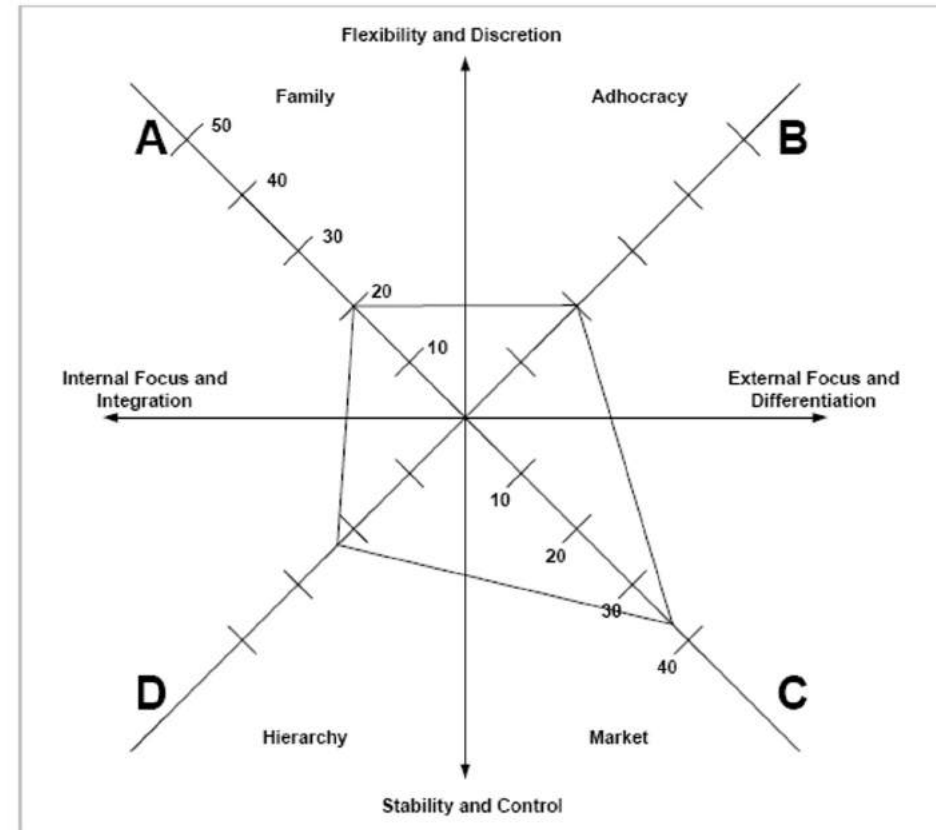

Rather than formal surveys, it can be effective to just *observe and ask*.

OCAI – Organizational Culture Assessment Instrument

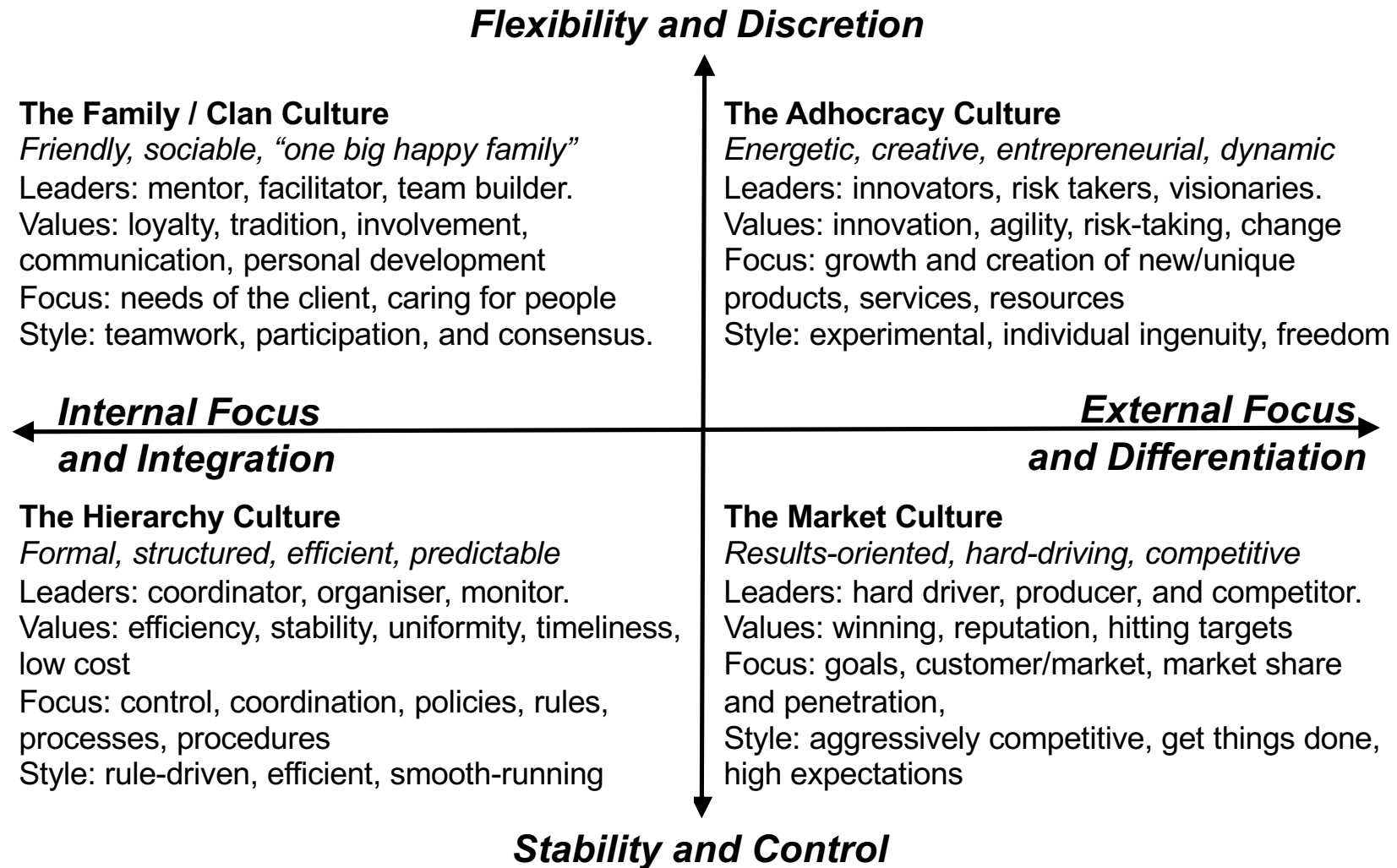

OCAI method

Test takers assess corporate culture, splitting 100 points over descriptions of the four culture types with respect to six aspects of the organisation – dominant characteristics, organisational leadership, management, etc. Done twice – current state and desired state

The culture profile illustrates:

- Current blend of cultures and the dominant culture
- Relative strength of the dominant culture
- Discrepancy between present and preferred culture
- Can also show “competing values”:

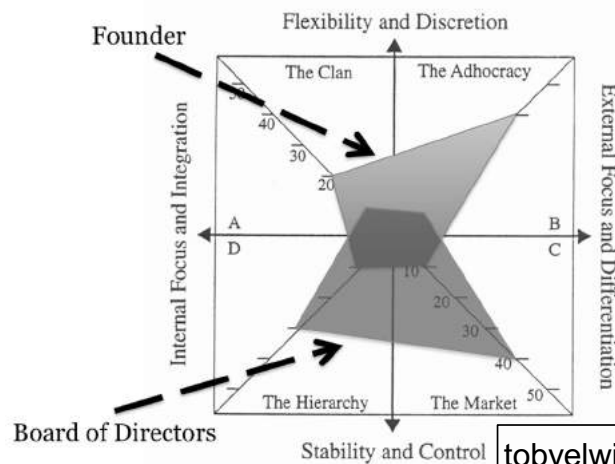

tobyelwin.com/competing-values-drives-your-organization-out-of-business

As noted before, you should always be *observing and asking*.

An example – 2

The “organisational review” at EdSave included an informal OCAI assessment:
Off the scale in “Market culture”, essentially 'zero' in “Family / clan culture”
This shaped the planning and design of the desired future state.

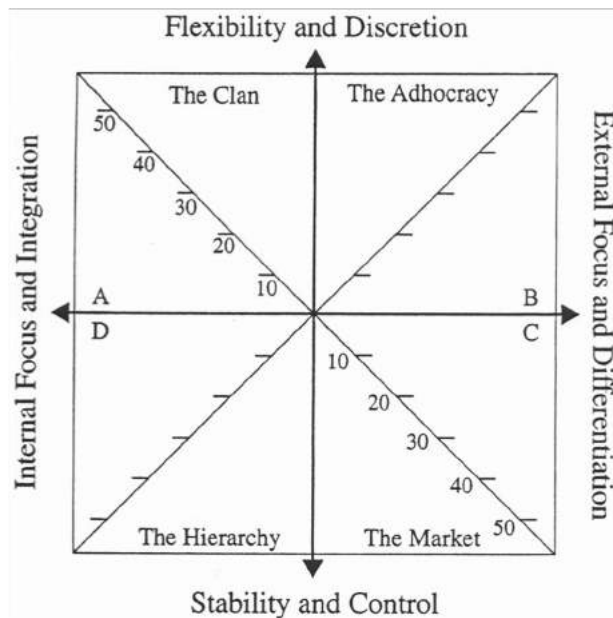

We didn't actually draw the chart – didn't have the data to back it up.
These often are drawn to show differences between two groups, or “current” and “desired.”

National culture

Modeling culture with Hofstede's cultural dimensions:

Small vs. large power distance	How less powerful members of groups perceive (and accept) that power is distributed unequally.
Individualism vs. collectivism	How an individual identifies with self or with group, how performance is seen as a group or individual function, ...
Masculinity vs. femininity	Value of competitiveness, aggressiveness, assertiveness, etc. vs. relationships, quality of life, etc.
Low vs. High uncertainty avoidance	Extent to which uncertainty and ambiguity are avoided; “strong avoidance” values standardization, structure, rules, ritual, etc.
Long vs. short term orientation	“Future leaning” attitudes, e.g. thrift and persistence vs. “past/present leaning” e.g. benefit now, respect for tradition, and reciprocity.

Understanding this has many implications for matching future state design to the organisation

Closing thought – procedure driving culture change

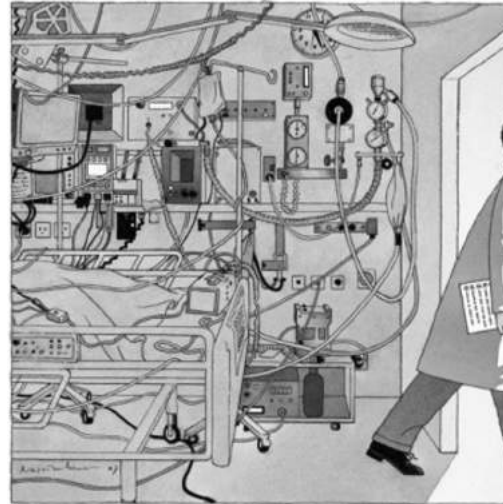

“The Checklist”
The New Yorker
Dec. 10, 2007 +
2011 Commencement Address,
Harvard Medical School

The point – fantastic statistical improvements in surgical outcomes from utilising a pre-surgery checklist.
Amazingly, this also drove *cultural change!*

7) *A feature-based approach to process design*

- 1) The essence of the technique is to identify each key feature of the to-be process, and determine what will be required (enabler by enabler) to make it work.

The alternative is to treat the entire to-be process as a “big bang,” implemented all or nothing.

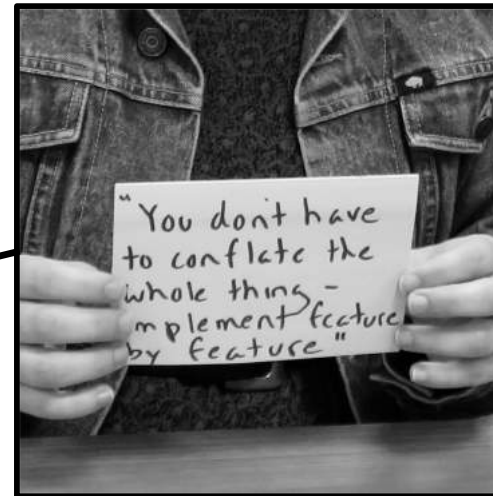

*Supports implementing change, feature by feature.
More in the upcoming section on design*

Making process modelling relevant

1. Communicating the fundamentals of *Business Processes*
2. Identifying true, end-to-end, cross-functional *Business Processes*
3. Developing a *Process Architecture*
4. Seven ways to help people embrace *Process Change*
5. *Human-oriented* process modelling
6. A feature-based *Process Design* method –
transitioning from *as-is* to *to-be*

Complete additional as-is modelling

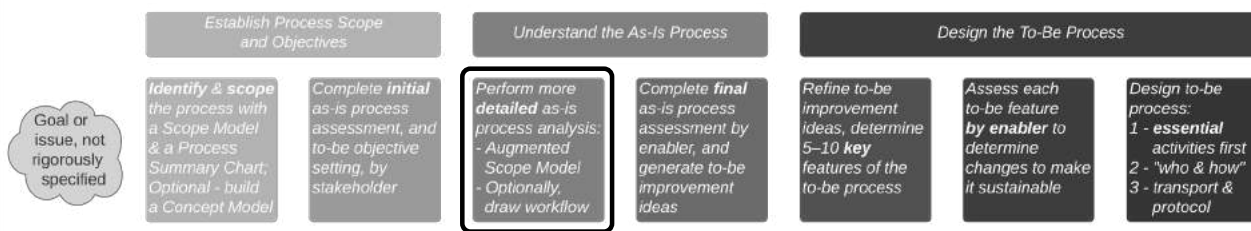

The goal is to *understand* the as-is process, not document it in *excruciating detail!*

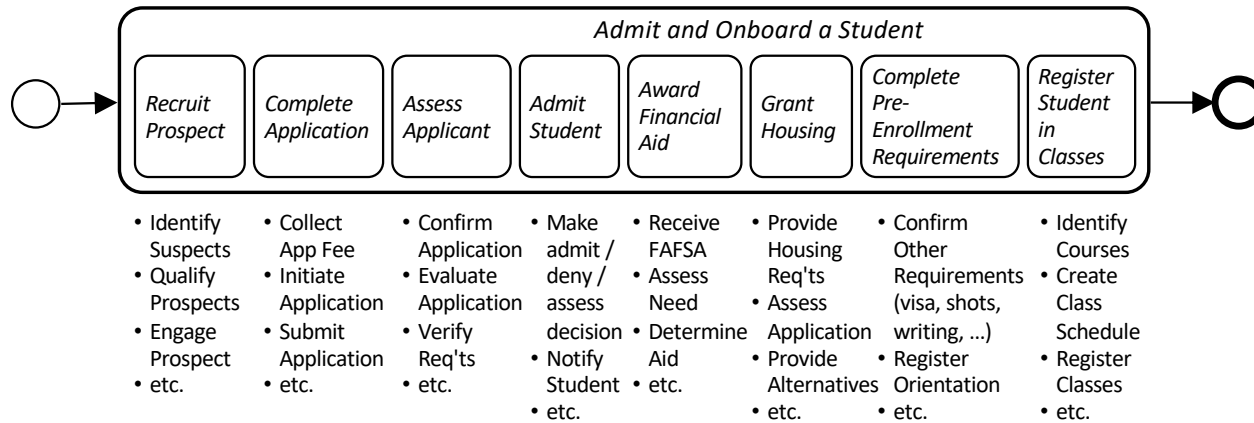

Optionally, model initial Workflow –

- Simplicity – minimal symbols and detail
- “Flow first, detail later!”

I always build an Augmented Scope Model –

1. What the *detailed* activities are, e.g.
“Register Class” (verb + noun)

2. Add *who* and *how*, e.g.,
“Advisor Register Class via SIS”

This is often good enough! – no need for an as-is swimlane diagram / workflow model

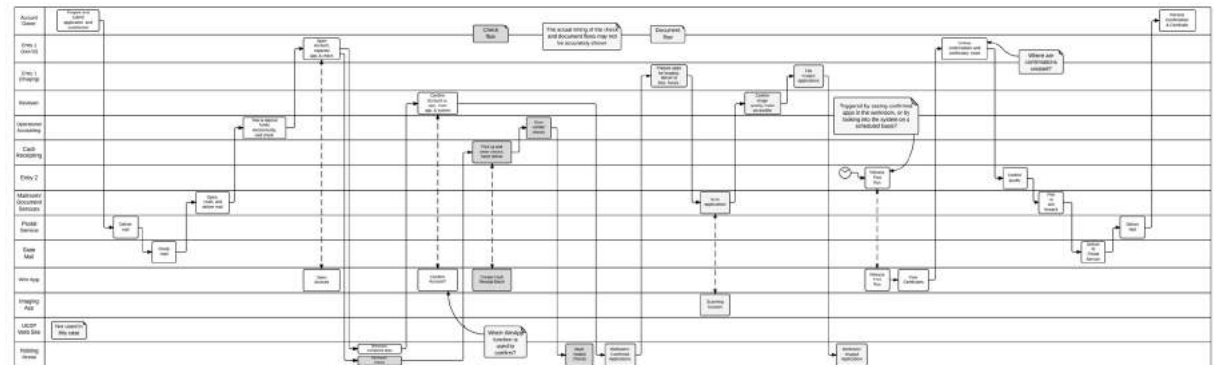

Simple Swimlane Diagrams – maximise their strengths

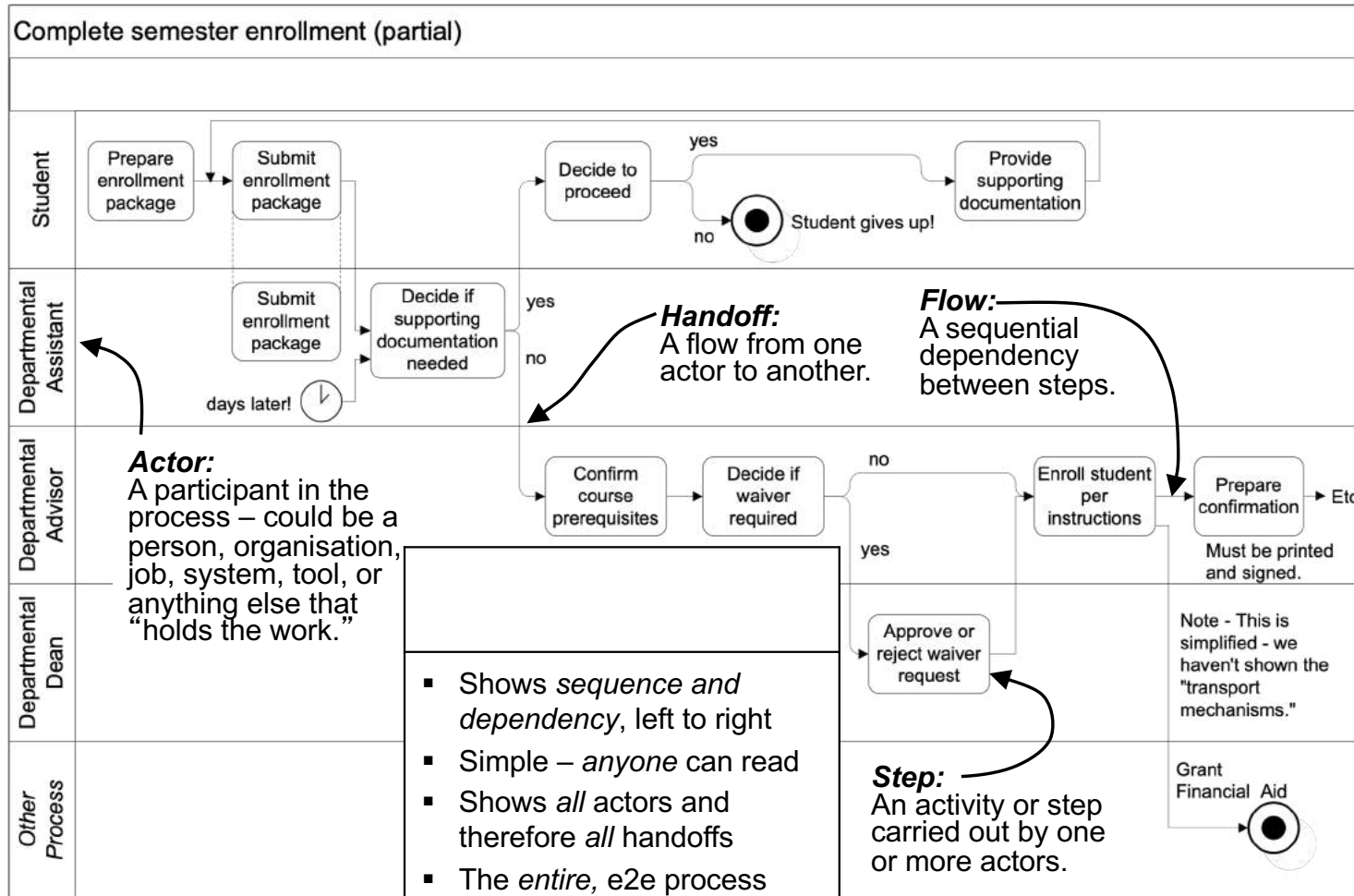

- Shows *sequence and dependency*, left to right
- Simple – *anyone* can read
- Shows *all* actors and therefore *all* handoffs
- The *entire*, e2e process
- *What*, but not *how*

Who – the actors

What – the steps

When – the flow

Other tools are better for capturing detail – *how* the steps are done:

- step-by-step procedures
- checklists
- decision trees
- use cases
- etc.

Why did simple Swimlane Diagrams become popular?

A quick Google Images search on "swimlane diagram" reveals...

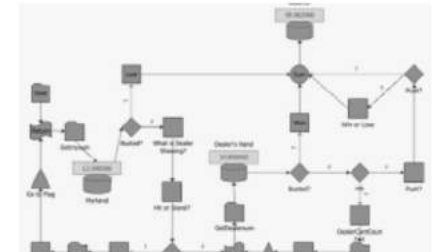
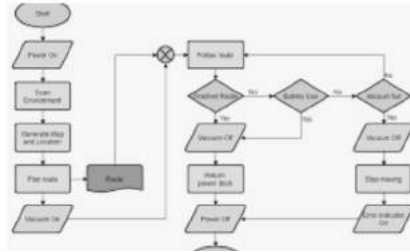
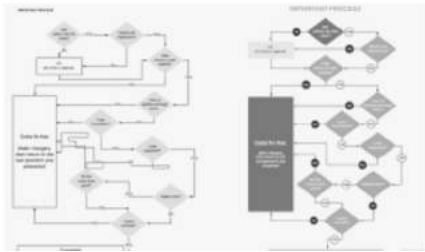

... lots of diagrams I might draw differently.

ips ...

Dota 2 Flow Chart ...
reddit.com

complex RENO flowcharts easier ...
weibull.com

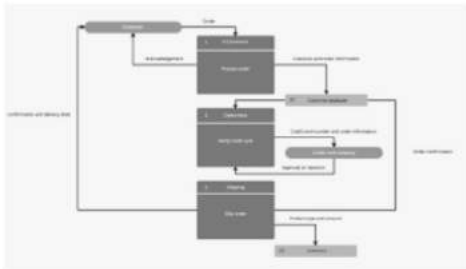

Follow flowchart best practices without ...
cacao.com



Flowchart Tutorial (Complete Flowchart ...
creately.com



21 Creative Flowchart ...
visme.co



Flowchart Programming ...
conceptdraw.com



Free Flowchart Templates ...
gliffy.com



Flowchart Tutorial (with Symbols, ...
visual-paradigm.com

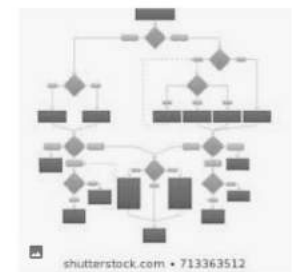
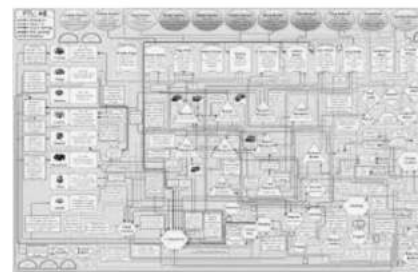
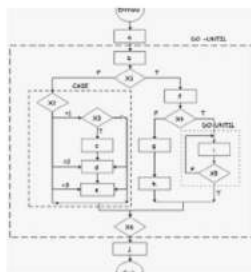
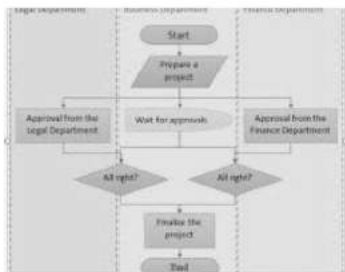

shutterstock.com • 713363512

One example... "Chaos With Colours"

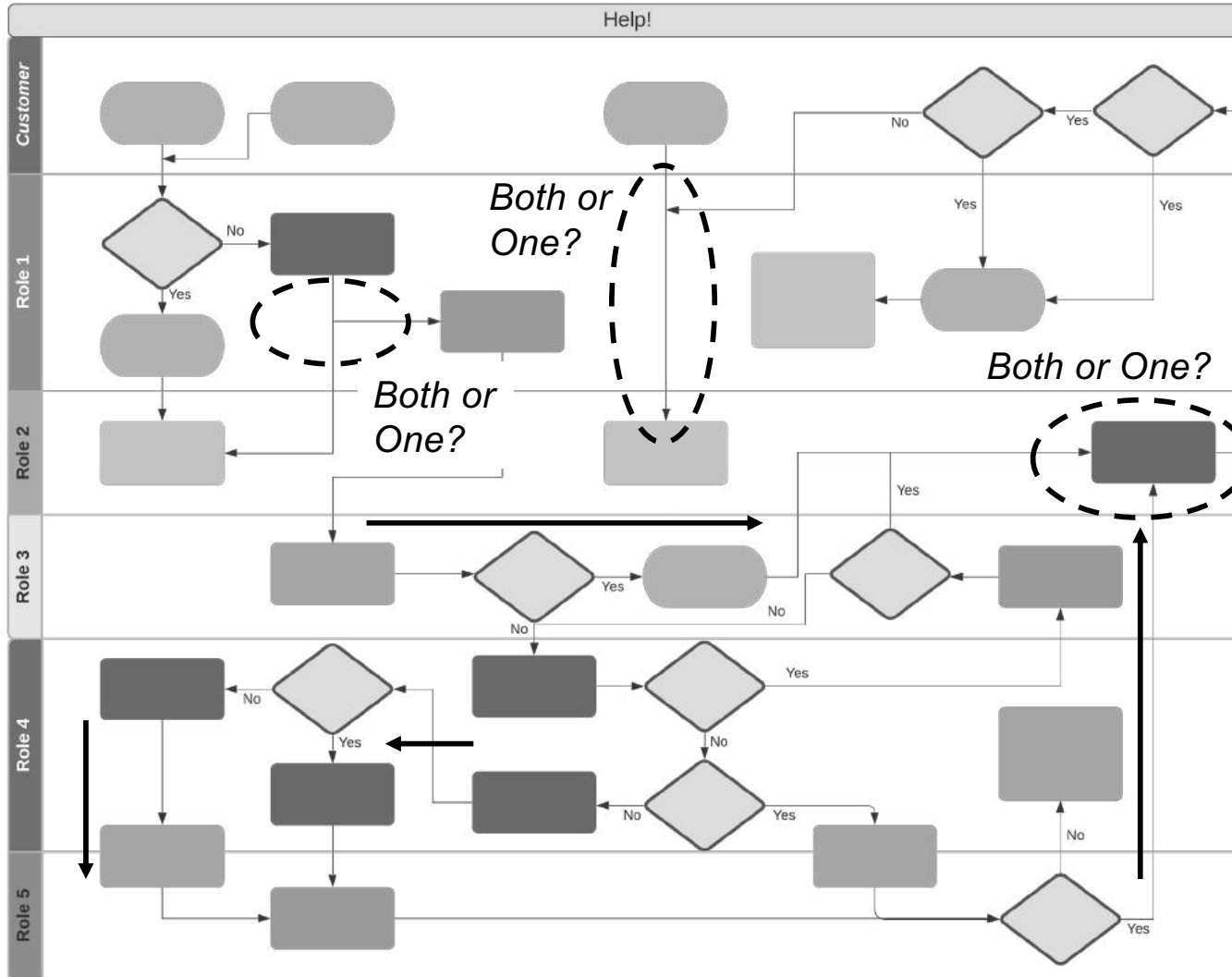

- Probably accurate,
not too many symbols, but...
- do unexplained colours help?
 - significance of multiple flows?
 - two separate flows inbound to a step
 - two joined flows inbound to a step
 - one outbound flow splitting
 - but most of all... flows in all directions!:
 - left to right
 - right to left
 - top down
 - bottom up

Why???

Forcing it into a "one-pager" defeats the graphic power of the diagram.

If you need a one-pager draw an Augmented Scope Model

Add 5 – 10
Activities per
Major Activity

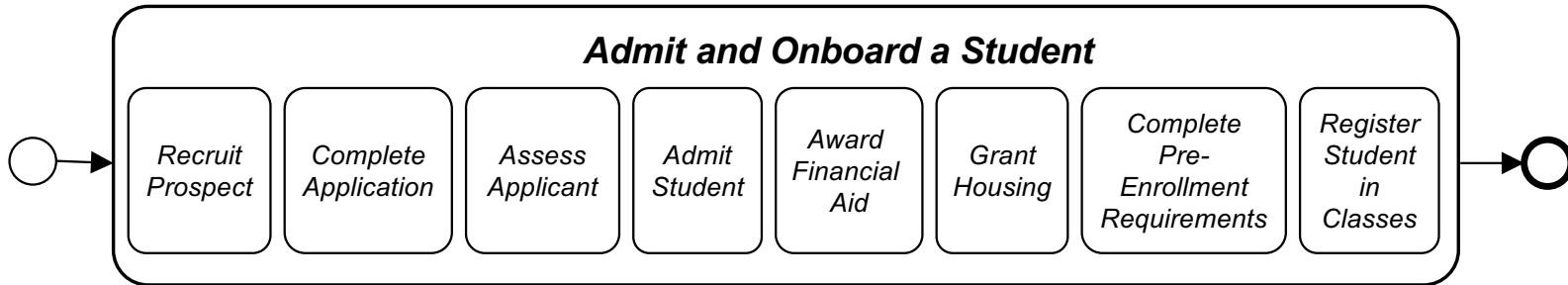

- Identify Suspects
- Qualify Prospects
- Engage Prospect
- etc.
- Collect App Fee
- Initiate Application
- Submit Application
- etc.
- Confirm Application
- Evaluate Application
- Verify Req'ts
- etc.
- Make admit / deny / assess decision
- Notify Student
- Complete Integrated Assessment
- etc.
- Receive FAFSA
- Assess Need
- Determine Aid
- etc.
- Provide Housing Req'ts
- Assess Application
- Provide Alternatives
- etc.
- Confirm Other Requirements (visa, shots, insurance, ...)
- Register Orientation
- Complete Orientation
- etc.
- Identify Courses
- Create Class Schedule
- Register Classes
- etc.

Later add
who & how to
each Activity

Who: Registration Assistant
What: Register Classes
How: via Workday SRS

Before "swimlaning"...

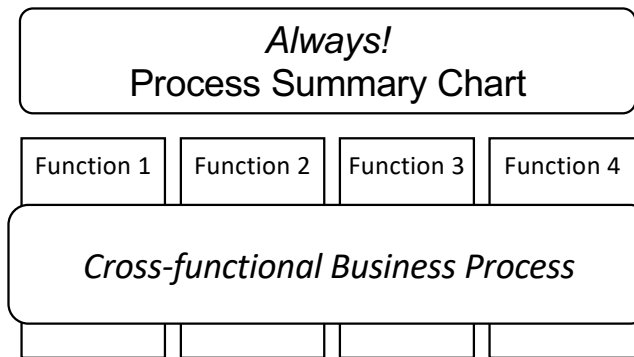
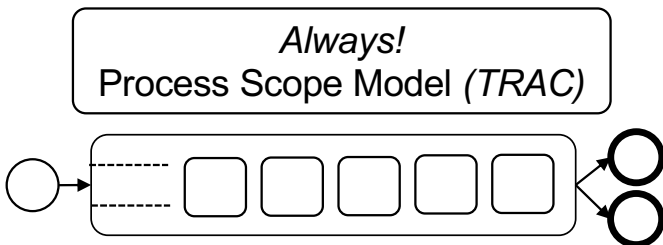

We're almost at swimlane level!

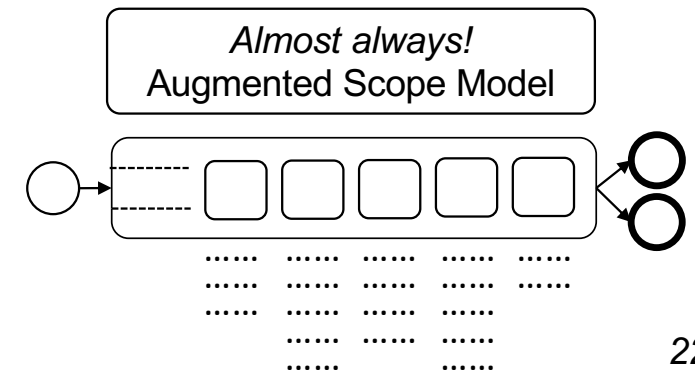

Another fast Augmented Scope Model example

Cases:

- \$5000 - \$25000 Goods
 - \$25000 - \$50000 Goods
 - \$5000 - \$25000 Services
 - \$25000 - \$50000 Services
- Assume everything <\$5000 is purchased with a PCard

This example adds detail by major Activity
(or subprocess/phase/milestone)

Triggering Event:

- Customer needs Good / Service

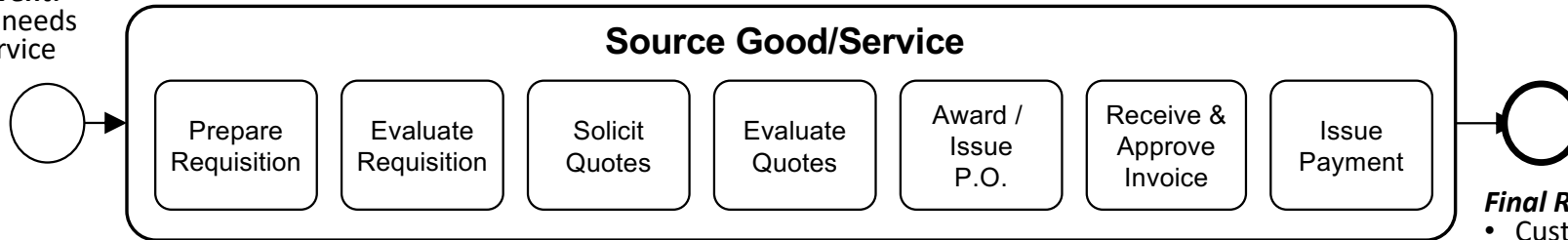

- Final Results:**
- Customer has received Good/Service:
 - Vendor has been paid
 - via A/P
 - via PCard

Develop scope of work / specs

Investigate potential vendors (and price?)

Solicit vendor quotes (just to get an idea)

Obtain approval (Department)

Verify Item and Account (General Accounting)

Submit requisition (visible to all)

Confirm completeness – get clarification this is actionable (scope sufficient)

Assign (or re-assign Buyer as necessary)

Identify MBE/SB opportunity (competitive) (co-op)
* sole source or co-op, vendor(s) known

Determine methodology
• sole source
• co-operative (piggyback on contract)
• competitive
• emergency

Determine (additional) potential vendors

Solicit quote (including Bid Due Date)

Post quote (solicitation documents) in "the binder"

Resolve vendor queries

* Up to \$200K, we control who gets solicitations; above, no control – it's "publicly advertised."

Over \$200K there would be 20 more activities, and could be multiple award.

Receive quote (mail, fax, e-mail, ...)

Confirm completeness

Verify suitable price, terms, and conditions (generally, low bid for equivalent)

Clarify (not negotiate) with vendor

Optional:
• Evaluate equivalency (for alternate)
• Confirm equivalency w. Customer

Identify vendor

- * If multiple line items, different line items could go to different vendors;
- * If multiple vendors, line items are not split.

Generate Purchase Order

Notify Requestor

"Transmit / deliver" P.O.
* Pain point – we aren't sure when the vendor receives the P.O.

Receive Good/Service
* Invoice could be attached

Accept Good/Service

Issue invoice (vendor)

Receive invoice:
• from vendor
• from the department the vendor sent it to

* Vendor complains invoice is "lost"

If >\$5000, match

- invoice
 - PO
 - receiver
- If <\$5000, match
- invoice
 - PO
- * Could invoice \$4K on \$40K PO

Batch invoices for GAD

Receive payment

Issue Payment (Magic Happens Here)

Core principles – "Flow first, detail later" and "Simplicity!"

The purpose of a *Workflow Model* is to show the *Flow of Work*

Whatever you call them, they are a *great* tool for showing flow – sequence and dependency of steps

- Swimlane Diagram
- Workflow Model
- Process Map
- Cross-Functional Flowchart
- People-Process Chart
- Functional Deployment Diagram
- Process Responsibility Diagram
- LOVEM Diagram
- ...

Left-to-right flow

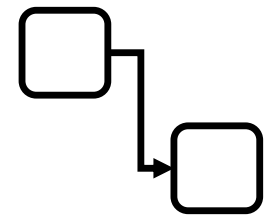
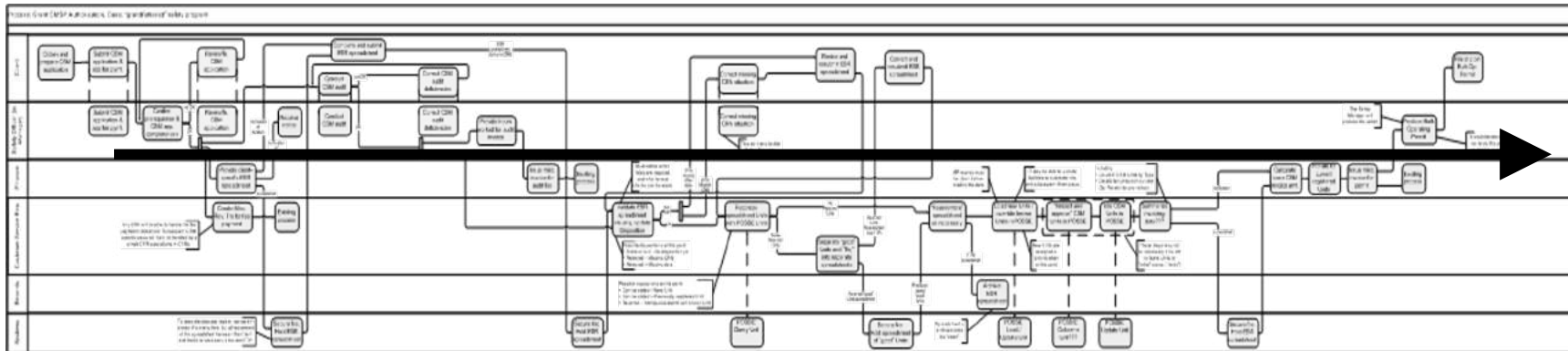

Simple... but not simplistic

Symbols were just boxes and lines

The Cognitive Psychology of diagramming

What do people first perceive on a diagram?

1. relative size

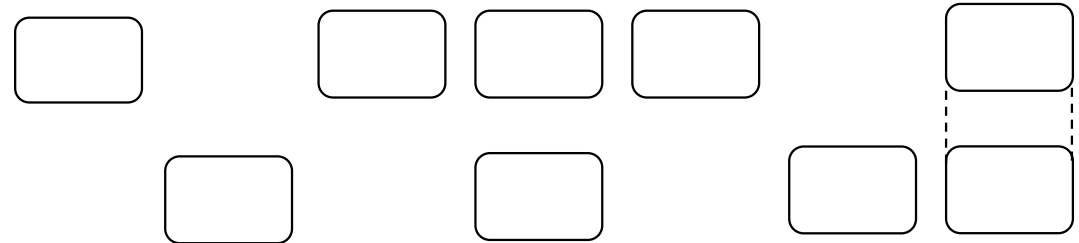
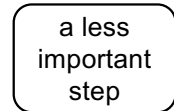
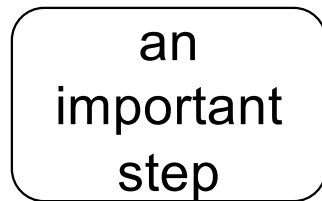

Make all the steps the same size,
unless you're trying to make a point

2. relative X-Y position

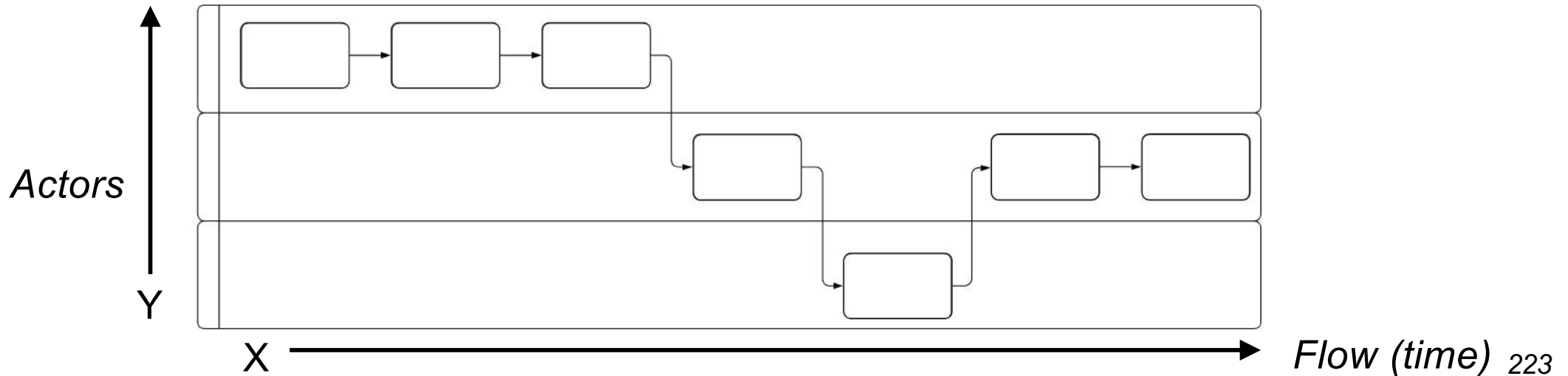

Don't conceal sequence and dependency

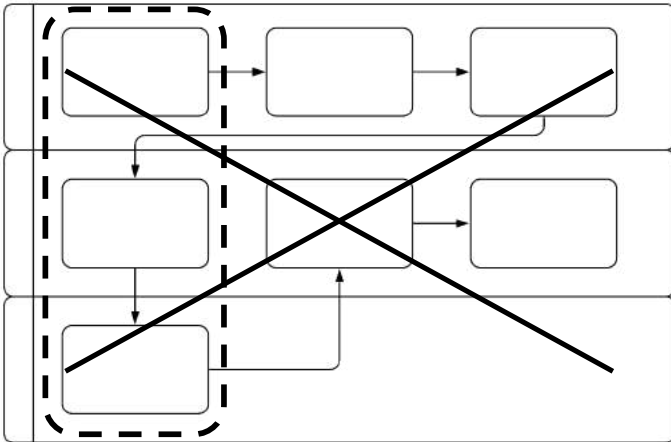

Steps perceived as happening in *parallel*, even though flow lines indicate *sequential*.

Critical in analysing a process:

- sequential vs. parallel
- dependent vs. independent

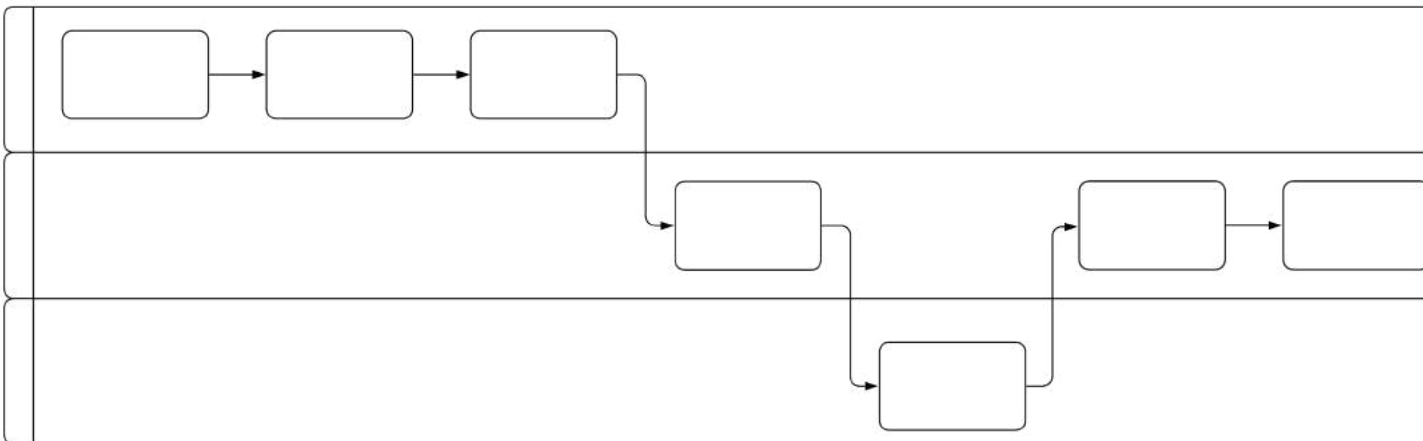

A simple guideline:
flow lines *only* leave
the right edge
and *only* enter
the left edge – never
the top or bottom.

"I think I know why our business partners don't want to review this..."

Probably a good DFD
(Data Flow Diagram)
useful to a technical
audience
Not a good
Process Flow Diagram,
useful to business
professionals, because...

- no obvious flow
- too many symbols
- cryptic acronyms
- lanes aren't actors
- ...

*What's wrong with this diagram
as a means of communicating
with a business audience?*

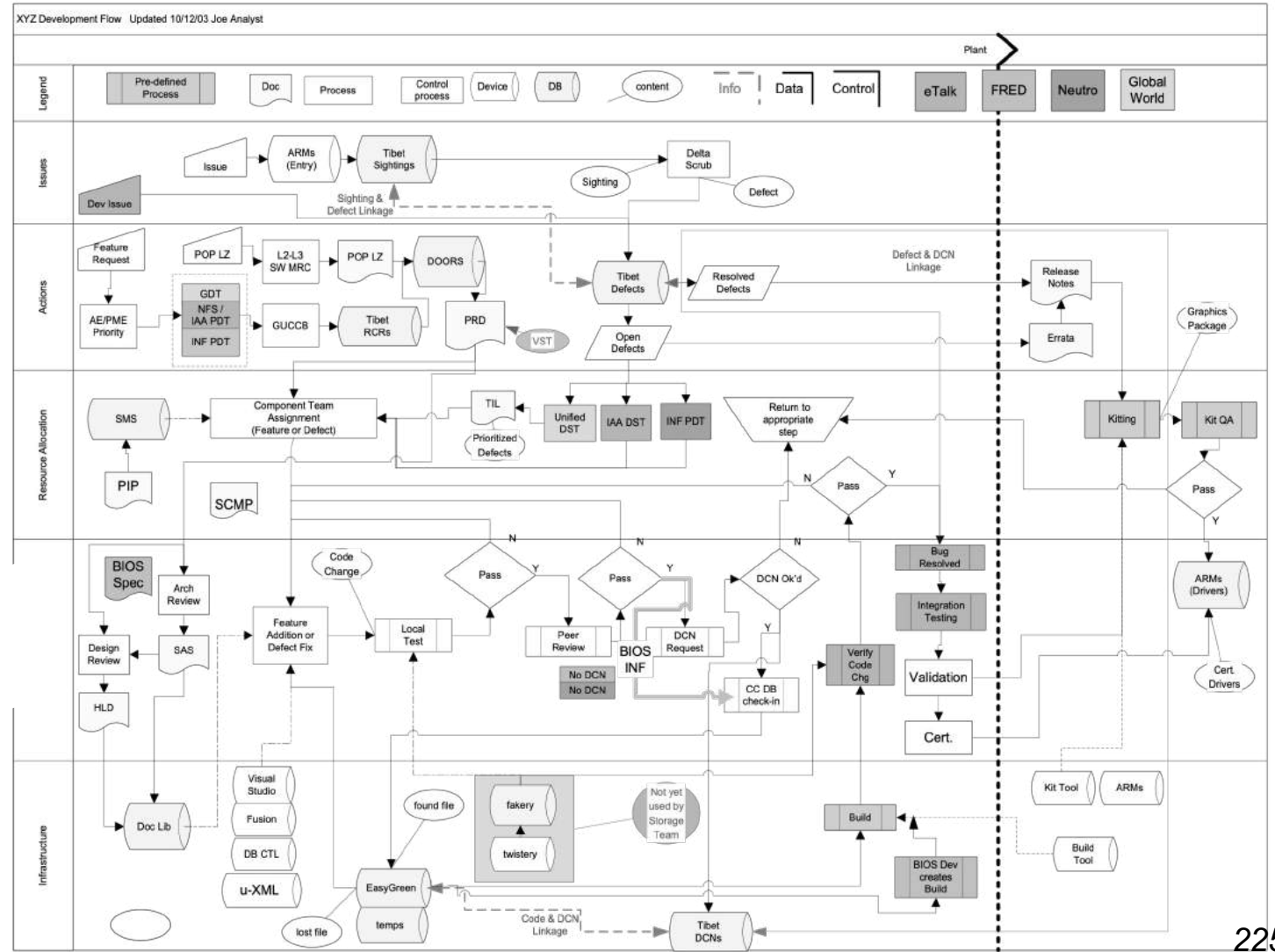

Boxes alone are a great start

Remember – you can build an initial flow model with Post-its, real or virtual

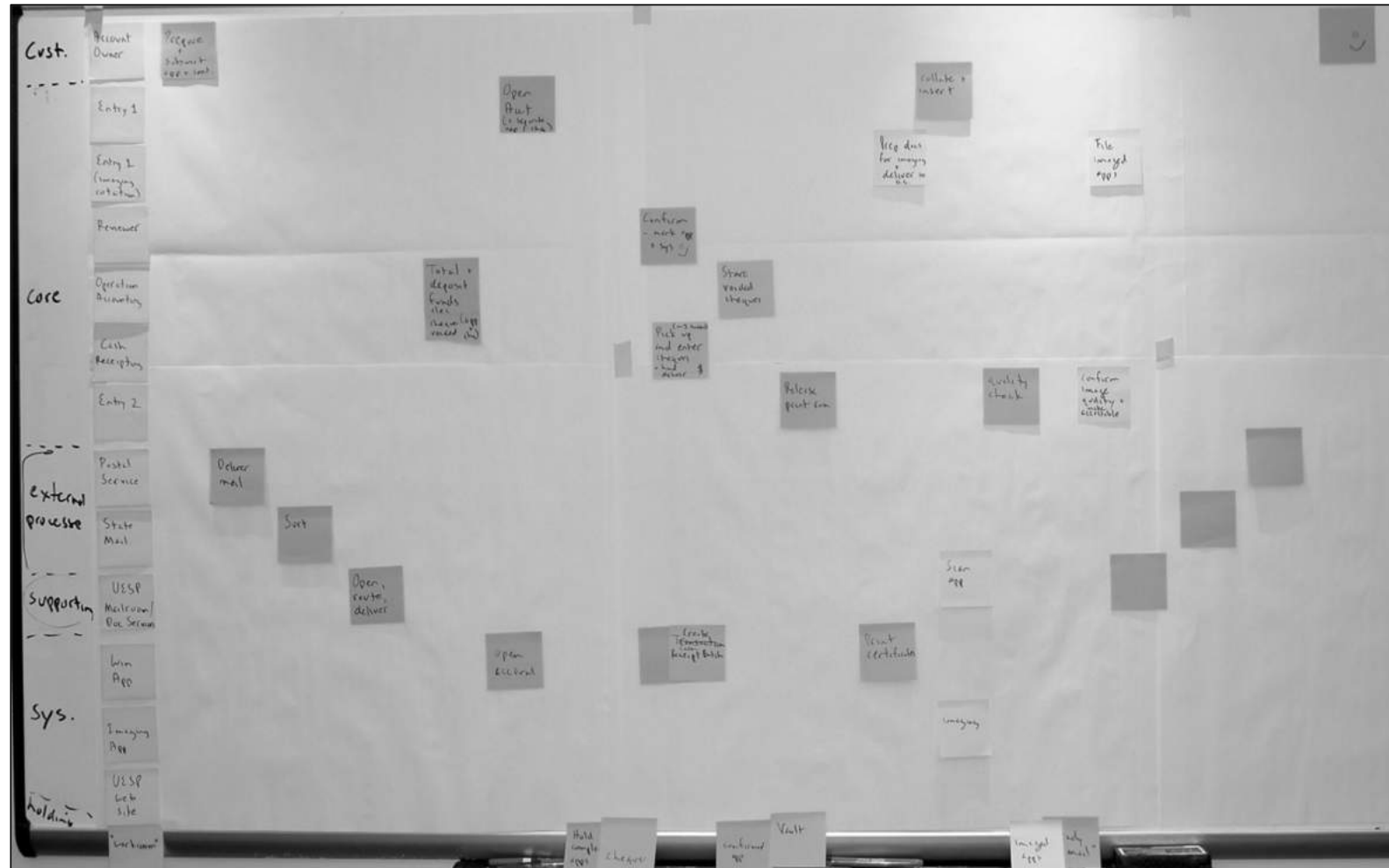

Minimal symbols

Later, redrew it with *Lucidchart* (www.lucidchart.com) –
add rigour, but still focus on flow and simplicity.

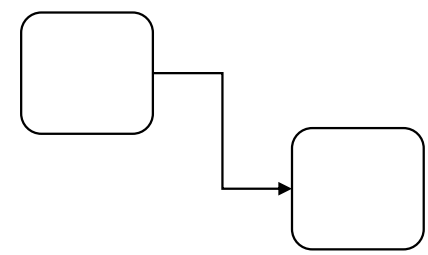
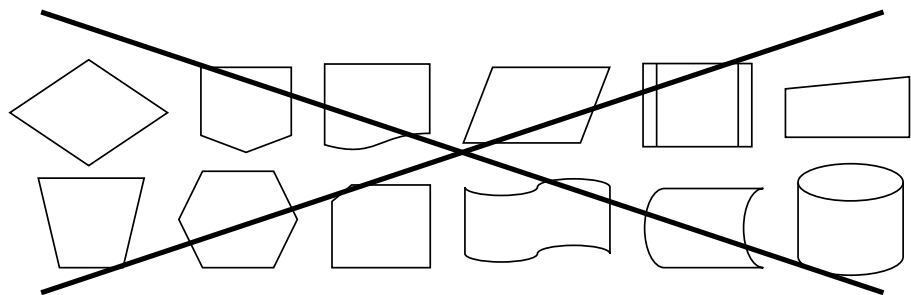
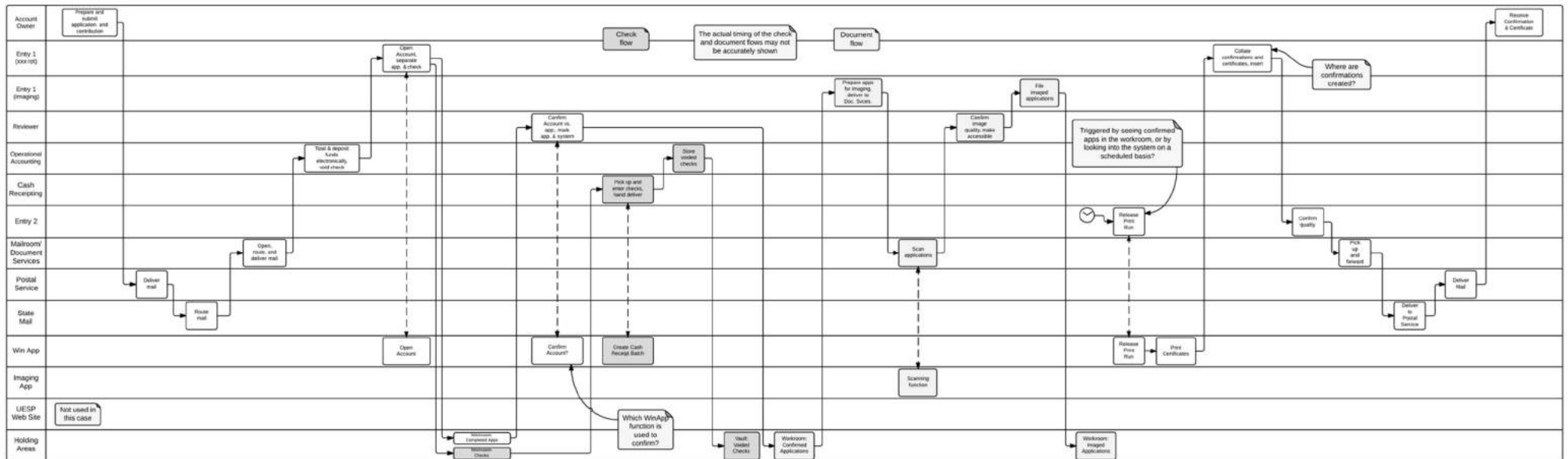

Full BPMN* – not useful for business purposes

If you choose to use BPMN, use extreme restraint! Only use a few symbols such as Lanes, Tasks, Flows, simple Events, and optionally Gateways

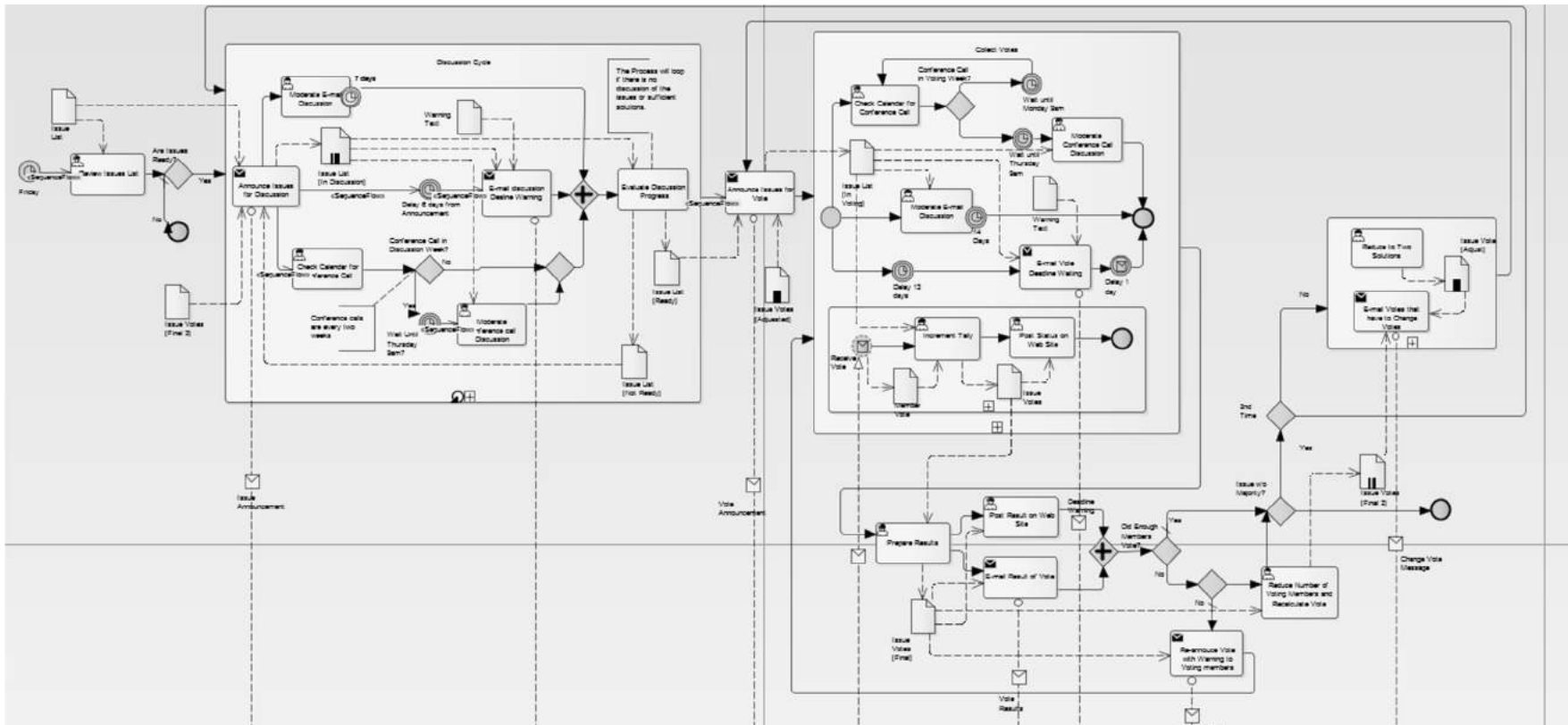

*Business Process Model and Notation, a standard by the OMG. BPMN was created to be a *visual programming language* for automating workflow, not for business modelling.

The full BPMN symbol set (why we use a subset)

BPMN 2.0 - Business Process Model and Notation

<http://bpmb.de/poster>

4 kinds of
Activities
(plus
Markers &
Task Types)

Activities

- Task**
A Task is a unit of work, the job to be performed. When marked with a [±] symbol it indicates a Sub-Process, an activity that can be refined.
- Transaction**
A Transaction is a set of activities that logically belong together; it might follow a specified transaction protocol.
- Event Sub-Process**
An Event Sub-Process is placed into a Process or Sub-Process. It is activated when its start event gets triggered and can interrupt the higher level process content or run in parallel (non-interrupting) depending on the start event.
- Call Activity**
A Call Activity is a wrapper for a globally defined Sub-Process or Task that is reused in the current process.

Activity Markers

Markers indicate execution behavior of activities:

- Sub-Process Marker
- Loop Marker
- Parallel MI Marker
- Sequential MI Marker
- Ad Hoc Marker
- Compensation Marker

Task Types

Types specify the nature of the action to be performed:

- Send Task
- Receive Task
- User Task
- Manual Task
- Business Rule Task
- Service Task
- Script Task

Sequence Flow

defines the execution order of activities.

Default Flow

is the default branch to be chosen if all other conditions are false.

Conditional Flow

has a condition assigned that defines whether or not the flow is used.

7 kinds of
Gateways

Gateways

- Exclusive Gateway**
When splitting, it routes the sequence flow to exactly one of the outgoing branches. When merging, it awaits one incoming branch to complete before triggering the outgoing flow.
- Event-based Gateway**
It is always followed by catching events or receive tasks. Sequence flow is routed to the subsequent event/task which happens first.
- Parallel Gateway**
When used to split the sequence flow, all outgoing branches are activated simultaneously. When merging parallel branches it waits for all incoming branches to complete before triggering the outgoing flow.
- Inclusive Gateway (instantiate)**
When splitting, one or more branches are activated simultaneously. All active incoming branches must complete before merging.
- Complex Gateway**
Complex merging and branching behavior that is not captured by other gateways.
- Exclusive Event-based Gateway (instantiate)**
Each occurrence of a subsequent event starts a new process instance.
- Parallel Event-based Gateway (instantiate)**
The occurrence of all subsequent events starts a new process instance.

Conversations

- A Communication defines a set of logically related message exchanges. When marked with a [±] symbol it indicates a Sub-Conversation, a compound conversation element.
- A Conversation Link connects Communications and Participants.
- A Forked Conversation Link connects Communications and multiple Participants.

Conversation Diagram

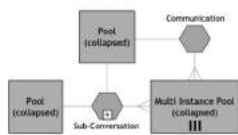

Choreographies



Choreography Diagram

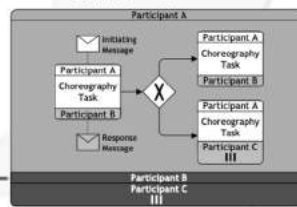

Collaboration Diagram

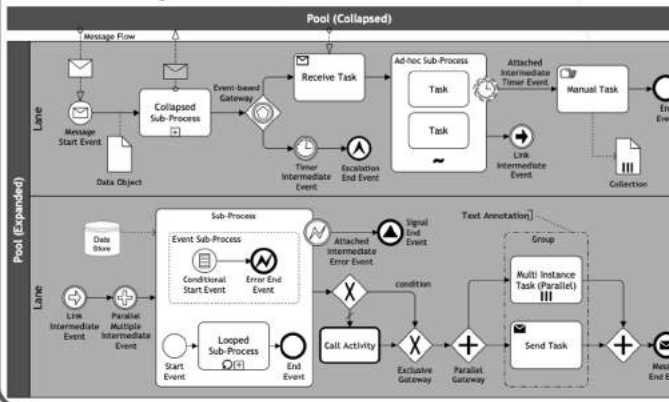

Swimlanes

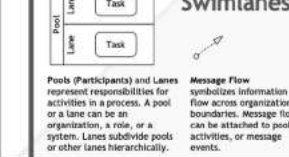

Events

	Start	Intermediate	End
None: Untyped events, indicate start point, state changes or final states.			
Message: Receiving and sending messages.			
Timer: Cyclic timer events, points in time, time spans or timeouts.			
Escalation: Escalating to an higher level of responsibility.			
Conditional: Reacting to changed business conditions or integrating business rules.			
Link: Off-page connectors. Two corresponding link events equal a sequence flow.			
Error: Catching or throwing named errors.			
Cancel: Reacting to cancelled transactions or triggering cancellation.			
Compensation: Handling or triggering compensation.			
Signal: Signalling across different processes. A signal thrown can be caught multiple times.			
Multiple: Catching one out of a set of events. Throwing all events defined.			
Parallel Multiple: Catching all out of a set of parallel events.			
Terminate: Triggering the immediate termination of a process.			

63 kinds of
Events

Data

- Data Input**: An external input for the entire process. It can be read by an activity.
- Data Output**: A variable available as result of the entire process.
- Data Object**: Represents information flowing through the process, such as business documents, e-mails, or letters.
- Collection Data Object**: Represents a collection of information, e.g., a list of order items.
- Data Store**: A place where the process can read or write data, e.g., a database or a filing cabinet. It persists beyond the lifetime of the process instance.
- Message**: Used to depict the contents of a communication between two Participants.

6 ways to
represent
Data



Minimal symbols for an approachable workflow model

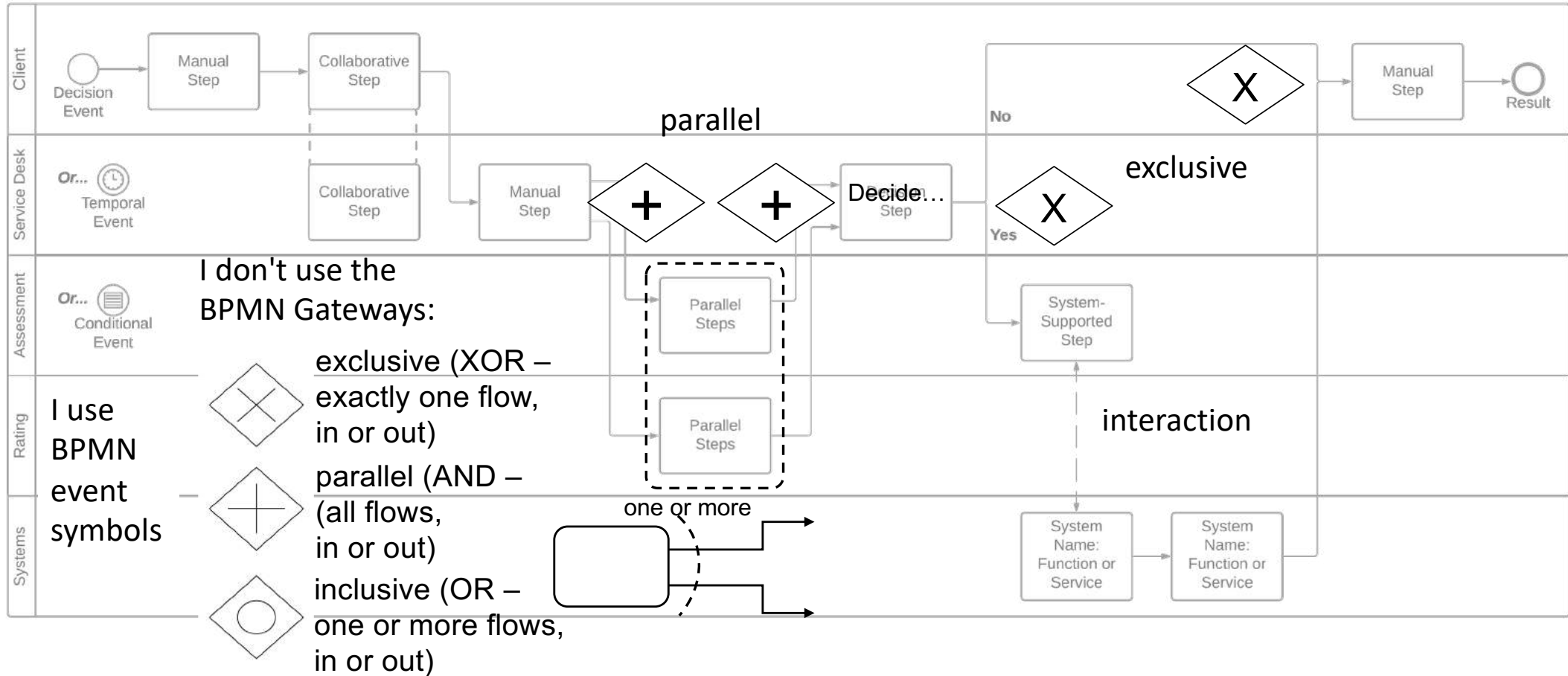

Striving for precision can undermine the purpose

Aristotle –

“It is the mark of an educated mind to rest satisfied with the degree of precision that the nature of the subject admits, and not to seek exactness where only an approximation is possible.”

Business-oriented workflow models will never simultaneously be:

- entirely precise and
- entirely generalised

Remember:

- diagrams convey concepts and structure – they tell a story
- other forms are better to convey detail – narratives, checklists, procedures, decision tables, use cases, activity diagrams / flowcharts, etc.

Three questions to develop your initial workflow model

Emphasis:

- keep you out of the details – focus on *flow*
- ensure the involvement of *every* actor is shown – it doesn't matter *how much* or *how little* they do, or whether they *add value*

Three simple questions:

1. “*Who* gets the work next?”
2. “*How* does it get there?”
– Often uncovers “transport” actors or systems
3. “*Who really* gets the work next?”
– Often uncovers additional actors

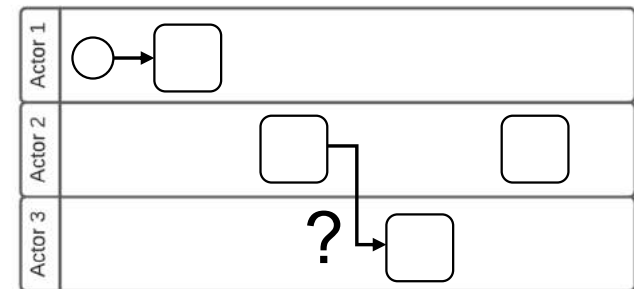

Guideline for the initial Handoff Diagram:
Whenever an actor *holds the work*, whether they do a *lot* or a *little*, draw *one* box (or post *one* sticky) and *move on!*
(And no value judgements – include *every* actor that holds the work!)

Question 1 – "Who gets it next?" traces overall flow

Process: Issue Building Permit
Case: Single Family Dwelling (SFD)

*My mantra –
"Flow first, detail later"*

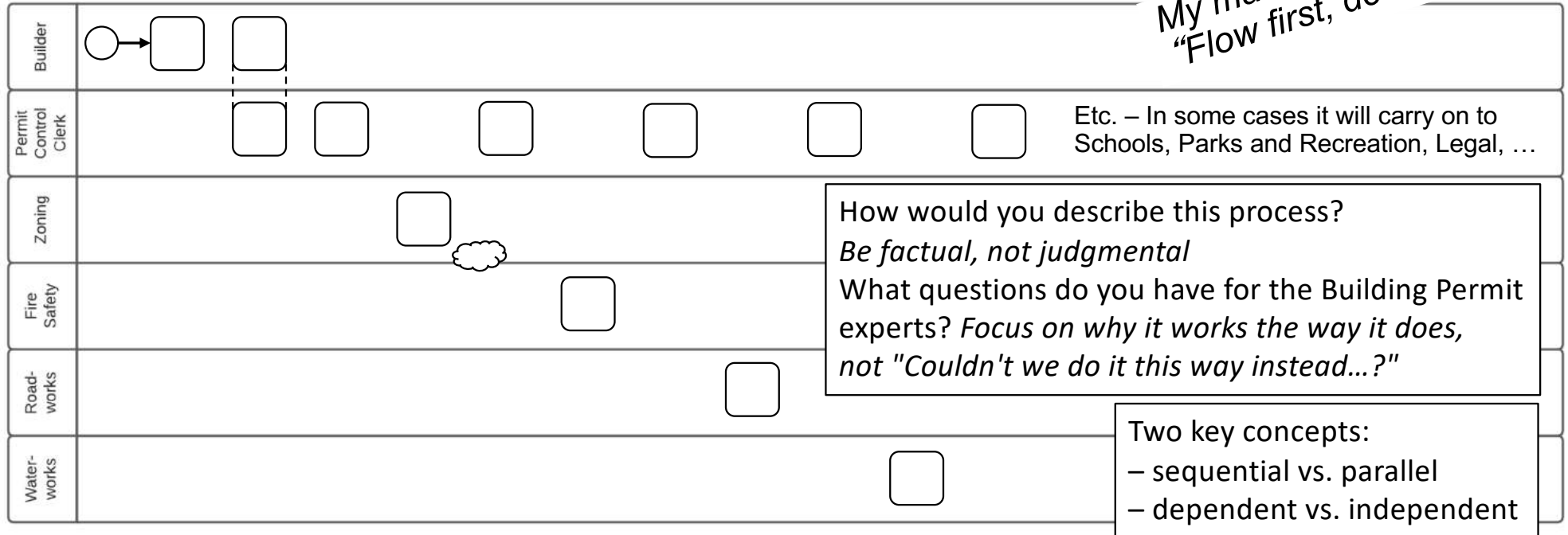

In scoping, you identified the trigger, the result, and the main actors. Now, starting at the triggering event, keep asking question 1 –
"Who gets the work next?"

- trace the flow of work through to the Customer's result, following one path only!
- at a decision or parallel flows, follow the main path, mark the other with a cloud, and return later
- **DO NOT** ask "What do you do?"

Question 2 – "How does it get there?" uncovers more actors

Process: Issue Building Permit
Case: Single Family Dwelling (SFD)

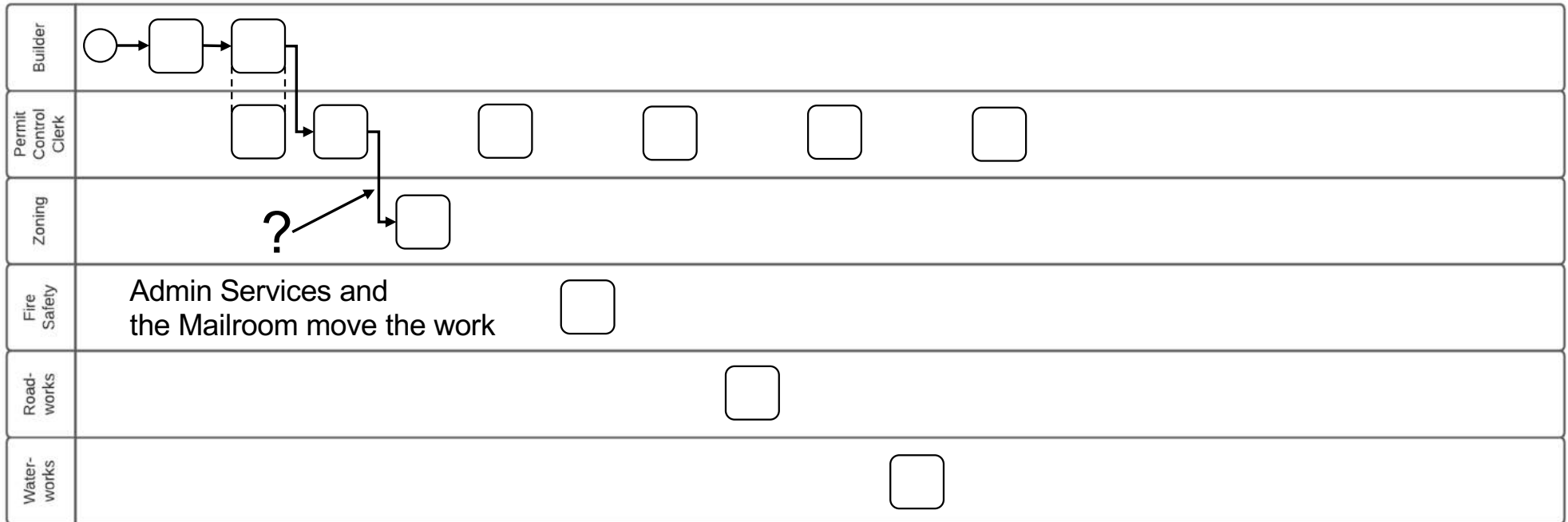

Next, at every handoff, ask question 2 –
"How does it get there?"

- uncovers *additional actors*, and therefore more handoffs
- a handoff is a potential source of *delay, error, or expense*

Question 2 revealed more actors and transport mechanisms

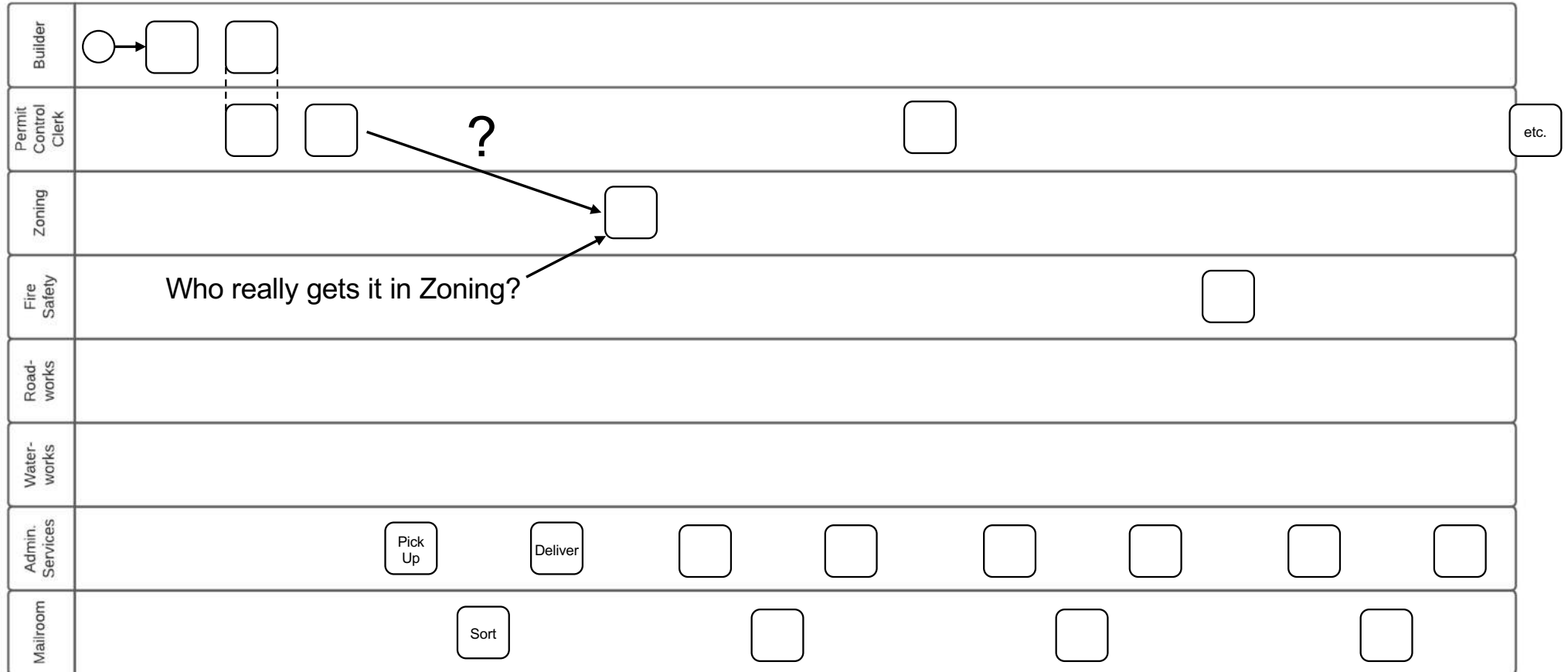

Now, inspect handoffs again, looking for missing actors, ask question 3 -
 “Who really gets it next?”
 - does it *really* go directly to the actor you first identified?

Question 3 – "Who really gets it next?" uncovers specific roles

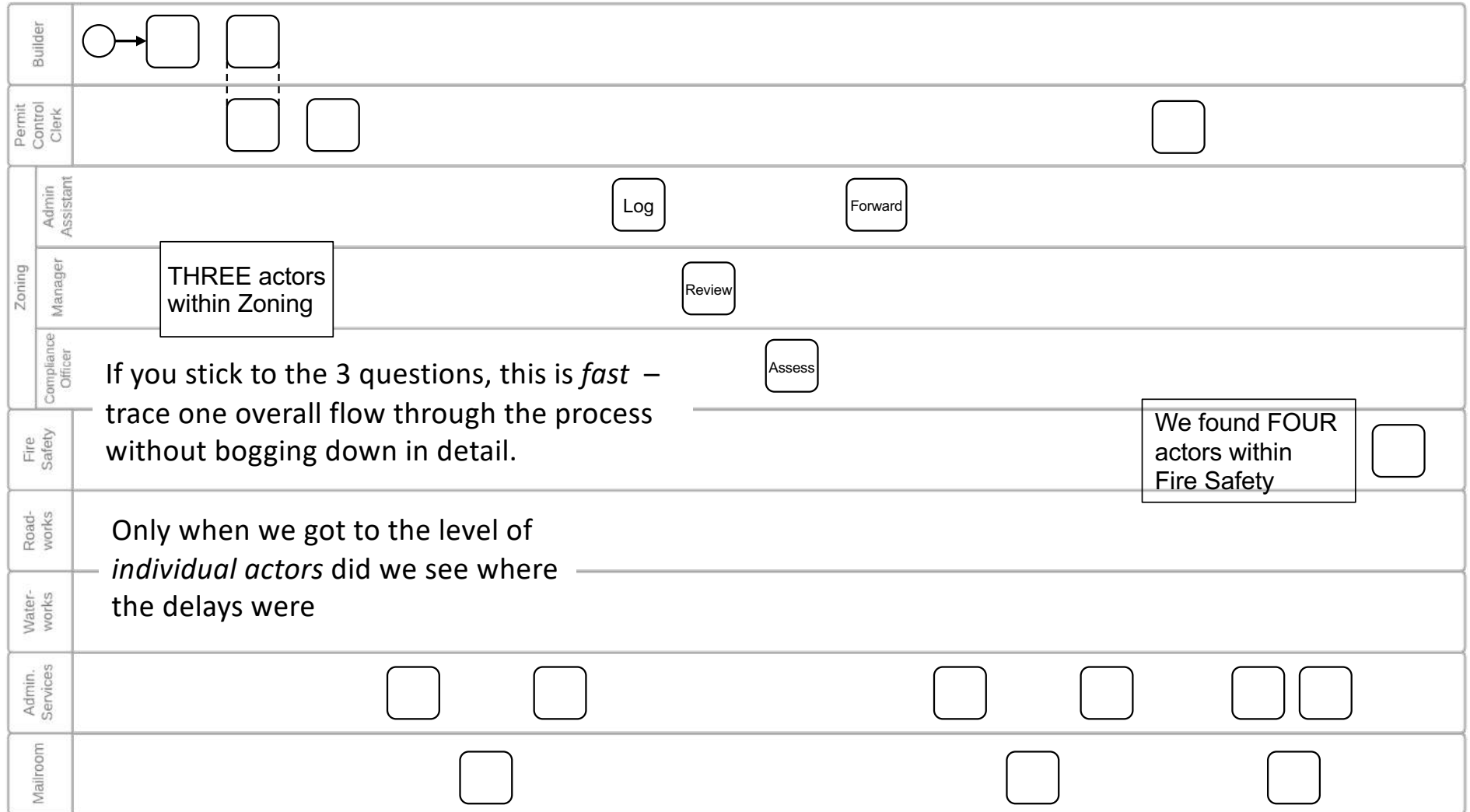

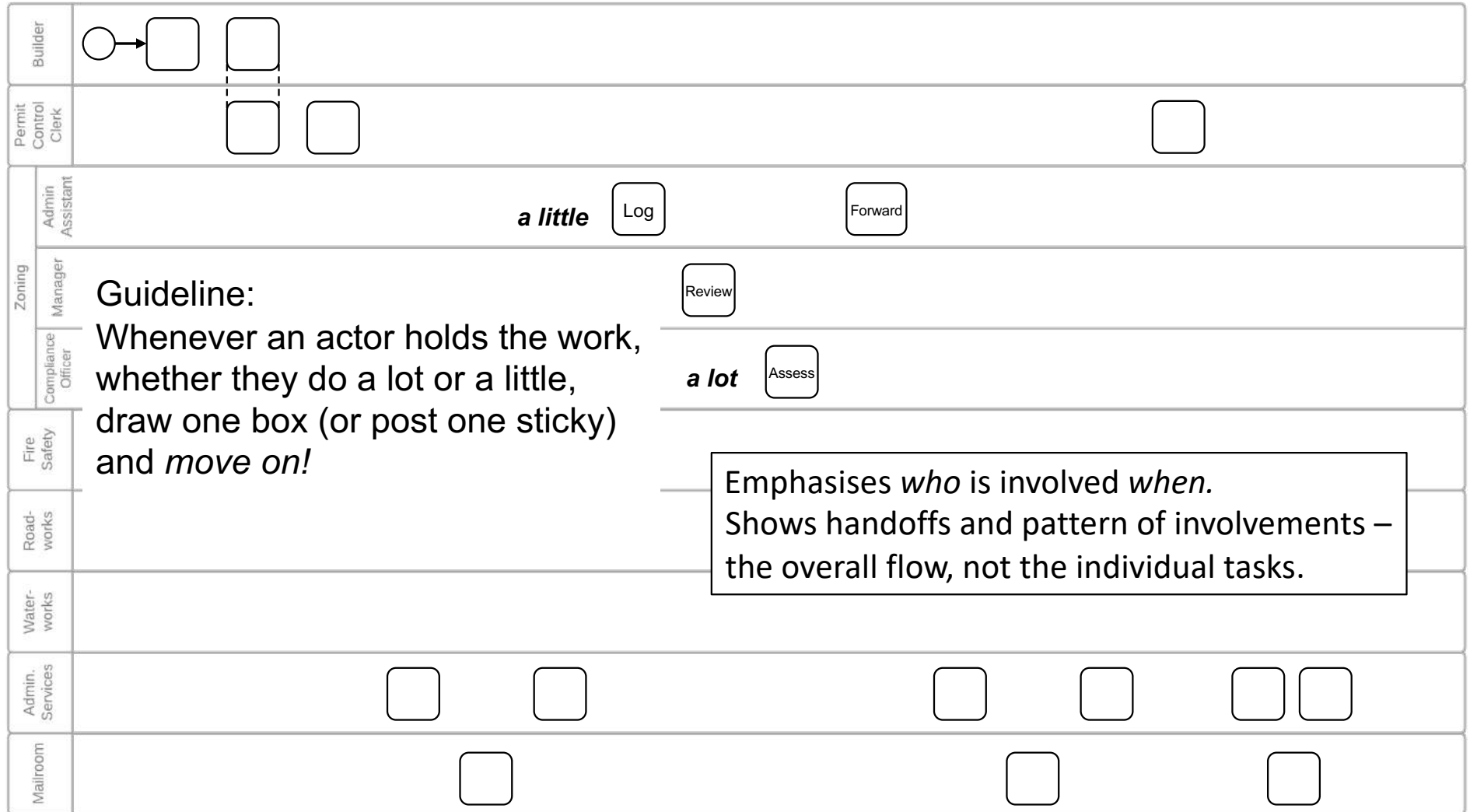

We have started a "Handoff Diagram"

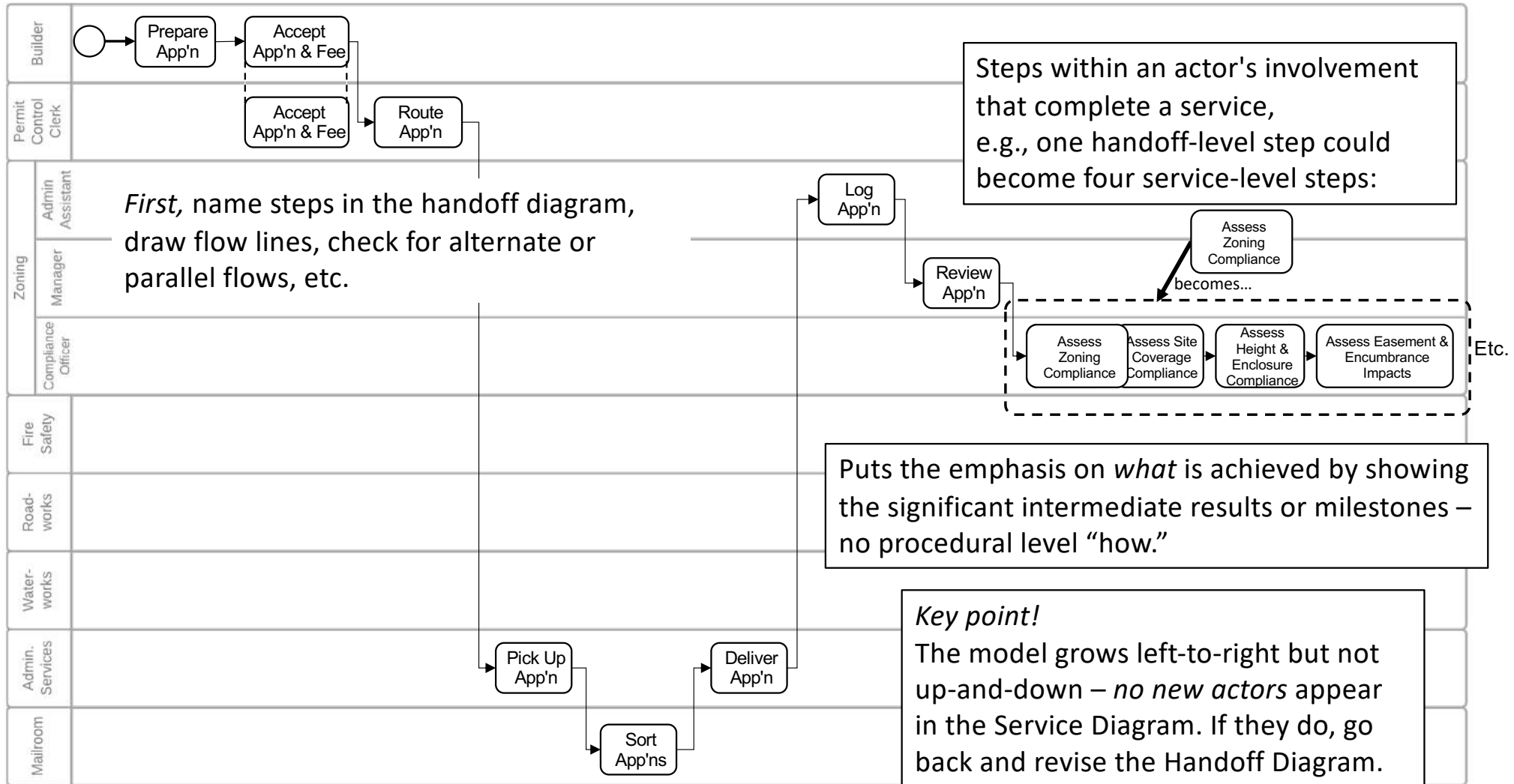

Now develop a "Service Diagram"

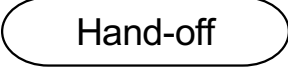
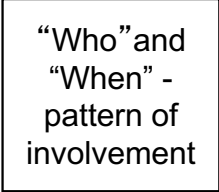

Two levels of swimlane diagrams

	Level	Definition	Emphasis	Notes
	1 	<ul style="list-style-type: none"> • Draw one step (box) every time an actor continuously “holds the work,” no matter how much or little they do 		<ul style="list-style-type: none"> • Sometimes this level of detail is enough to understand As-Is process behaviour
	2 	<ul style="list-style-type: none"> • Decompose handoff-level steps into discrete services, <i>as necessary</i>: one step each time actor achieves a significant result or state change 		<ul style="list-style-type: none"> • Usually, we don't go any further than this for the As-Is process • Also called a “Milestone” diagram

The handoff-level diagram is critical – ensures we discover the overall flow before diving into detail.

What stands out on this minimalist Handoff Diagram?

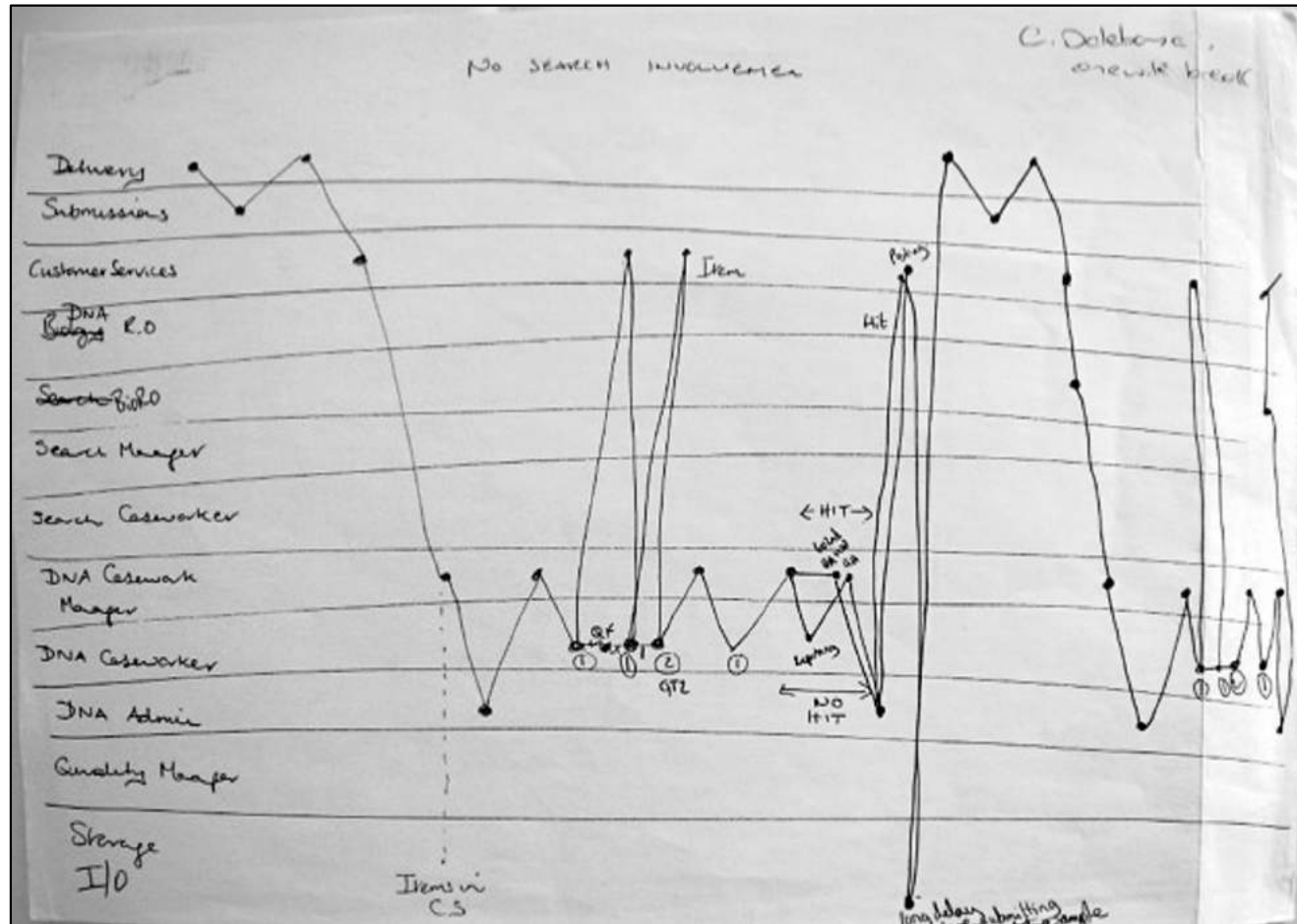

“Order and simplification are the first steps to mastery of a subject.”
Thomas Mann

We learned a LOT in a short period of time

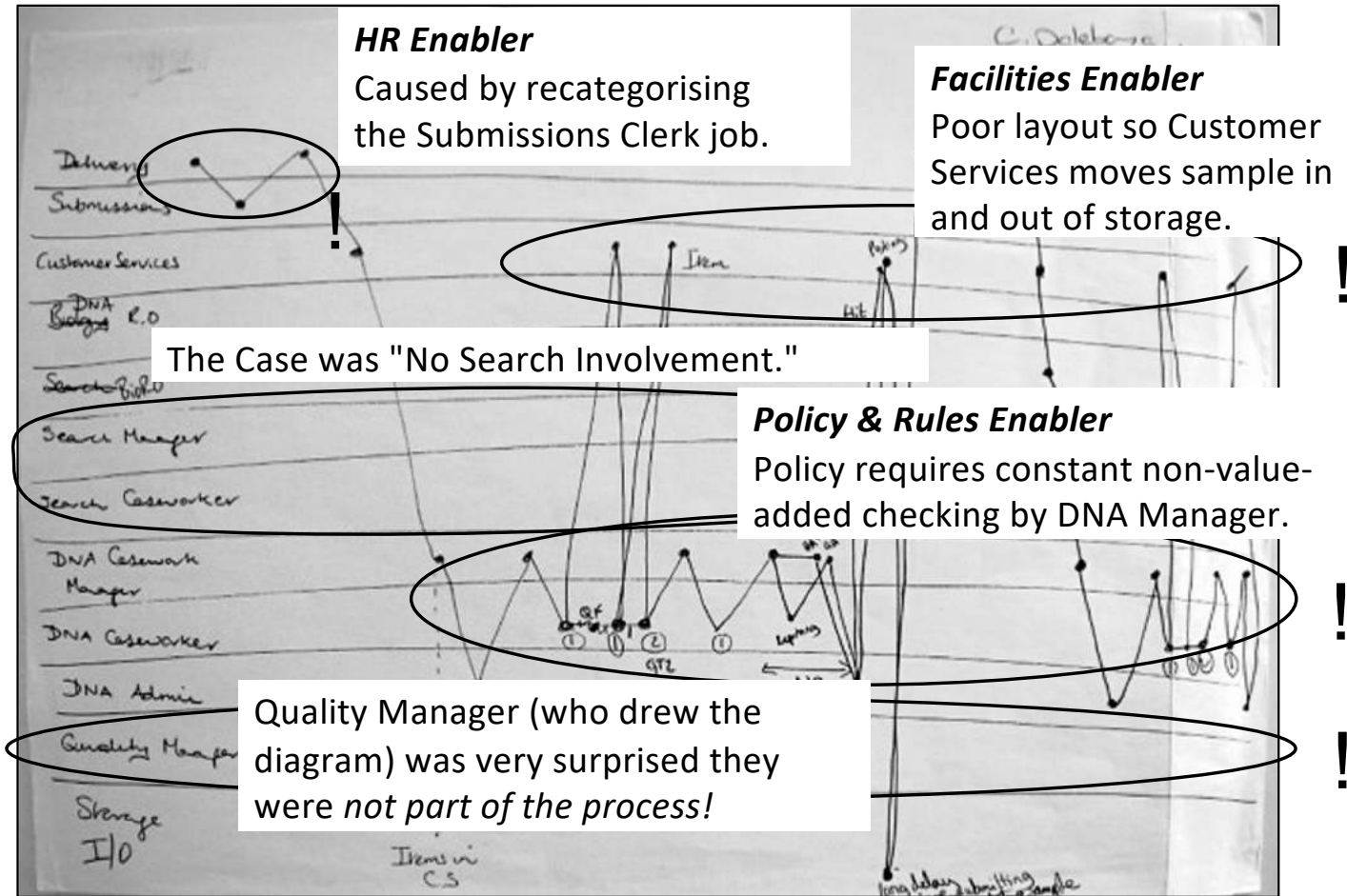

Business
Process
Design
(Workflow)

Technology &
Information
Systems

**Motivation &
Measurement**

**Human
Resources &
Organisation**

Policies & Rules

Facilities
(or, Knowledge /
Info / Data,
Communications,
Documents, ...)

The Service level workflow

- Purpose -

Understand the actual contribution of each actor to the process

Ensure feasibility and effectiveness of process
(can each actor actually perform their steps?)

Show relationship to systems - steps involving automated support correspond strongly to use cases and services

Key points:

- Steps within an actor's involvement that complete a service
E.g., *one* handoff-level step could become *five* service-level steps:



One handoff-level step

One or more service-level steps

- Puts the emphasis on *what* is achieved during the process by showing the significant intermediate results or milestones –
“the achievements, not the individual tasks”

Reminder: the service level ties in Use Cases and Services

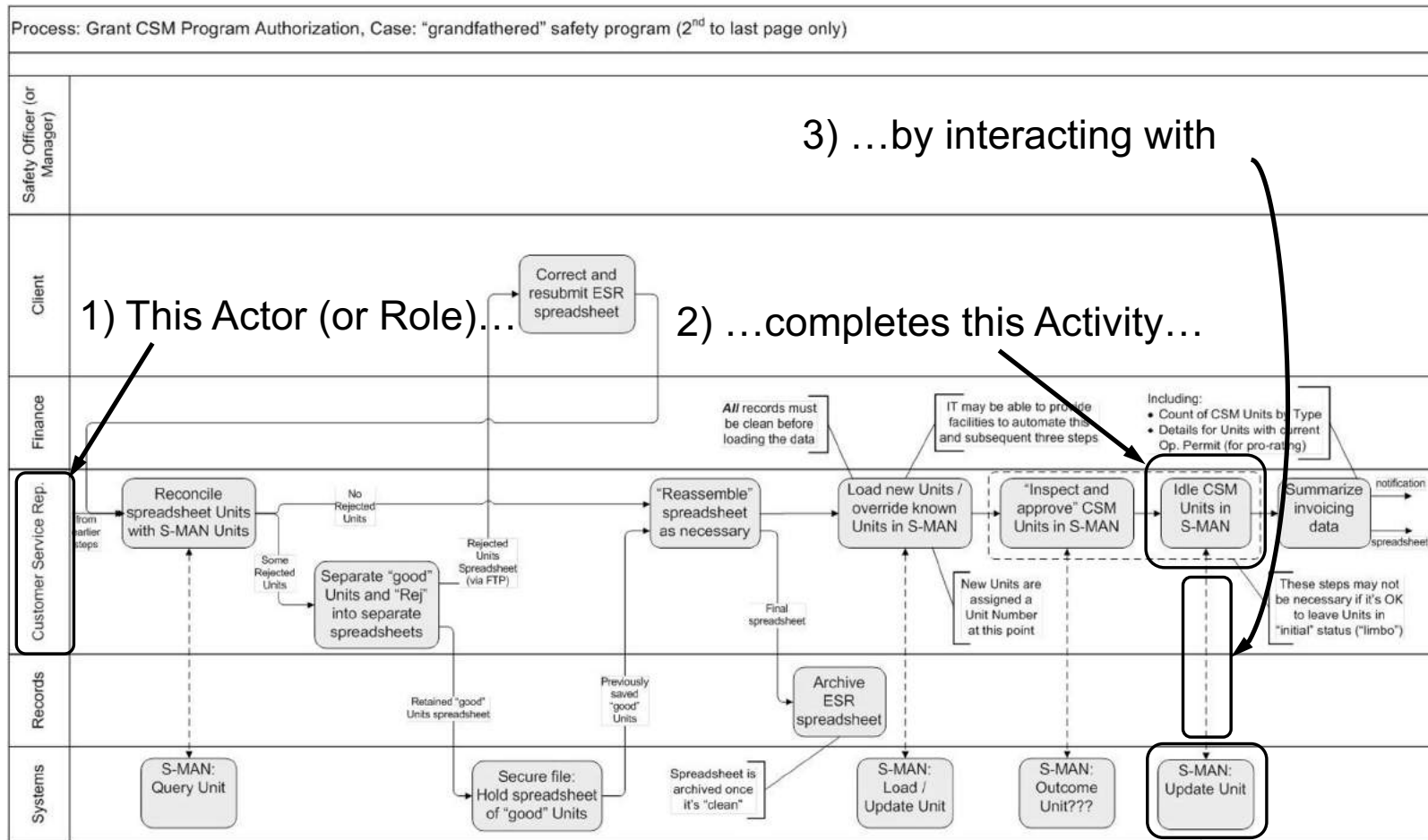

4) ... this Service offered by a System (which collectively is a Use Case)

Stop diagramming before you get into “how”

Stop workflow modelling when work isn't flowing.

Do **not** use a workflow model to describe **how** an activity is done – that belongs in the activity description or in a linked document.

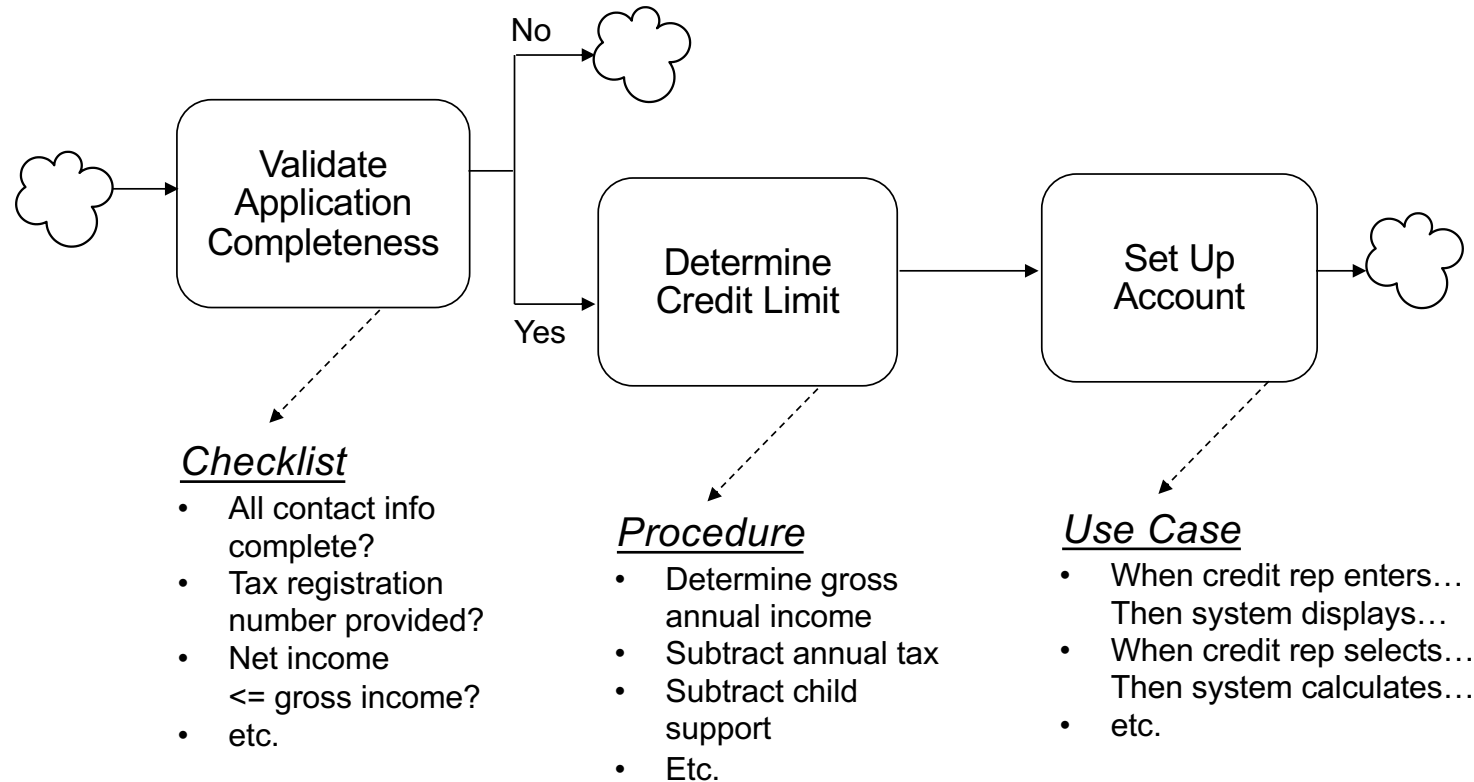

Knowing when you've gone too far

Do **not** use a workflow model to describe **how** an activity is done – that belongs in the activity description or in a linked document.

Handle TEO
(Telecom Equipment Order)

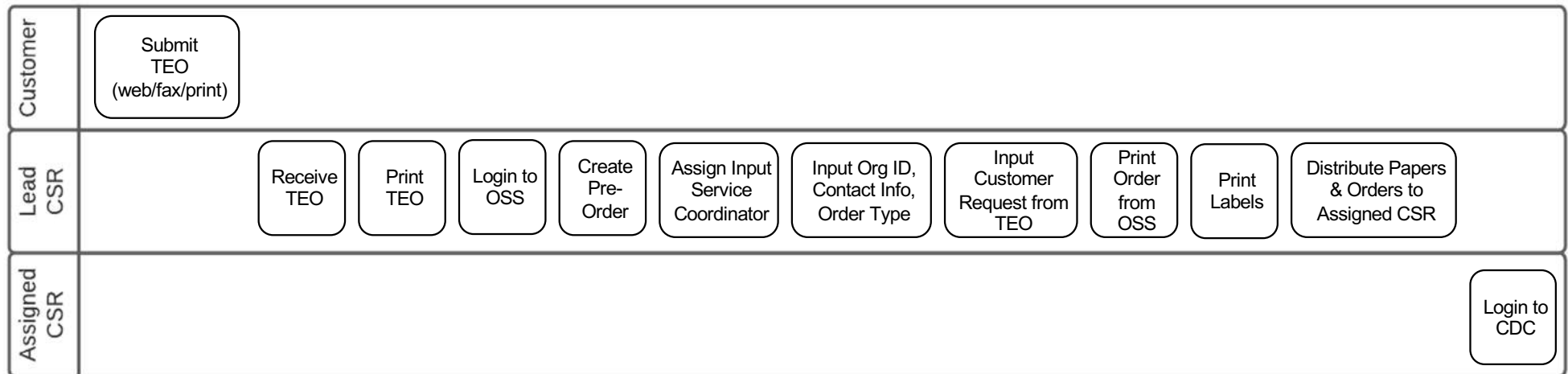

You've gone too far if:

- there are multiple steps in sequence by the same actor
- the steps include "how-to" instructions (procedural level detail)

Summary – where we've been, where we're going

Principles

The purpose of a *Workflow Model* is to show the *Flow of Work*

Simplicity is a virtue

Always do a Scope Model and a Summary Chart before flow modelling

Why they work

Flow (sequence & dependency) is clearly visible, left to right

Simple to read – the symbols are mostly boxes and lines

Shows all actors and their steps, and therefore all interactions and handoffs

Shows the entire, end-to-end process, from trigger to results

Shows "what" the steps are without diving into "how"

The most *common* errors

Concealing flow by drawing a convoluted diagram, usually in an attempt to make it a "one-pager"

Using a lot of symbols that regular folks don't understand

Omitting actors just because they play a minor part – *everyone* has an impact

Cutting the diagram into one-page segments – the initial flow model should be continuous

Using a Workflow Model to document procedural level detail

Business Process assessment (as-is) and design (to-be)

1. Communicating the fundamentals of *Business Processes*
2. Identifying true, end-to-end, cross-functional *Business Processes*
3. Developing a *Process Architecture*
4. Seven ways to help people embrace *Process Change*
5. *Human-oriented* process modelling
6. A feature-based *Process Design* method –
transitioning from *as-is* to *to-be*

Before we do a "formal" as-is assessment...

1. Record first impressions, and identify obvious problems and NVA (non-value added) work
2. Identify the cause of problems in the initial assessment
3. Identify *leverage points* –
A point in a process that has a *disproportionate impact* on overall performance.
 - Often early in the process
 - Most “bang for the buck” – *fix first!*



Leverage point examples:

- Sales reps dislike returning to the office to submit orders, so, they submit in bulk at the last minute, causing a surge in workload
- Forensics lab accepts *all* items submitted, in the mistaken belief they are *legally obligated* to accept all of it, even though much of it is *redundant* or *useless*

...then apply structured, enabler-based techniques

Two critical techniques address common problems:

1. *Problem:* focusing excessively on *workflow and IT*.
Solution: conduct a *final assessment* that holistically addresses *all enablers* and generates potential improvements
2. *Problem:* implementing process “improvements” that have *unforeseen consequences* (negative and/or expensive)
Solution: assess significant improvement by specifically considering each of the six *enablers*

Result: a set of to-be process characteristics (“features”) that:

- impact specific issues
- are consistent with one another and the differentiator
- are feasible with respect to culture, resources, ...

Key point – don't jump into workflow design too soon!!!

The link between the As-is Process and the To-be Process

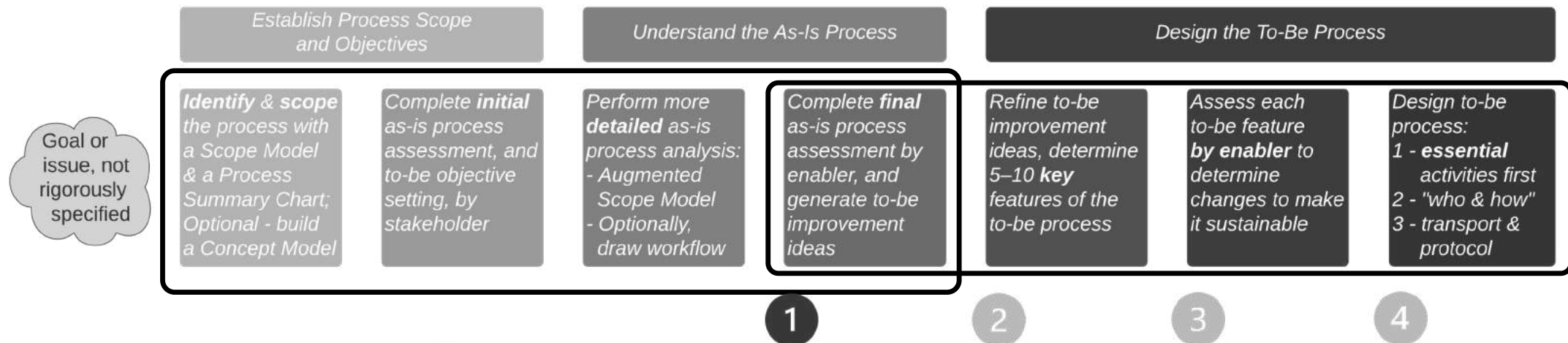

This phase (1) marks the pivot from as-is to to-be:

- we capture what we learned while studying the *as-is*
- we use this to generate ideas for the *to-be*
- three more phases (2 3 4) lead us to a new design

Key point!

Much of what we learn comes from discussions along the way, not from studying the swimlane diagram.

Complete final as-is assessment, generate to-be ideas

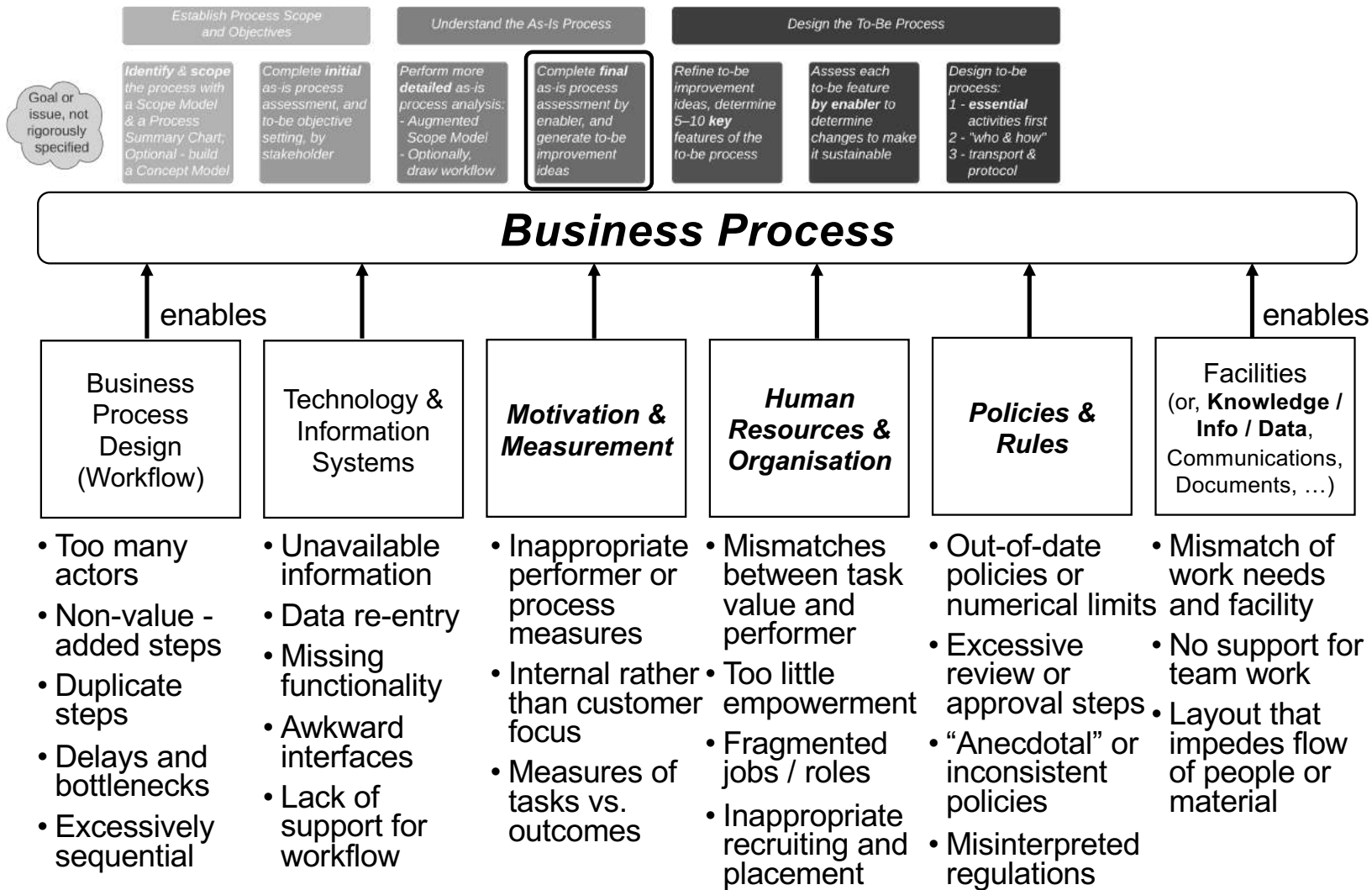

Considering all six enablers is at the heart of this methodology

This *always* uncovers issues that would have been missed otherwise and *always* generates ideas (potential *features*) for the to-be process

A few examples...

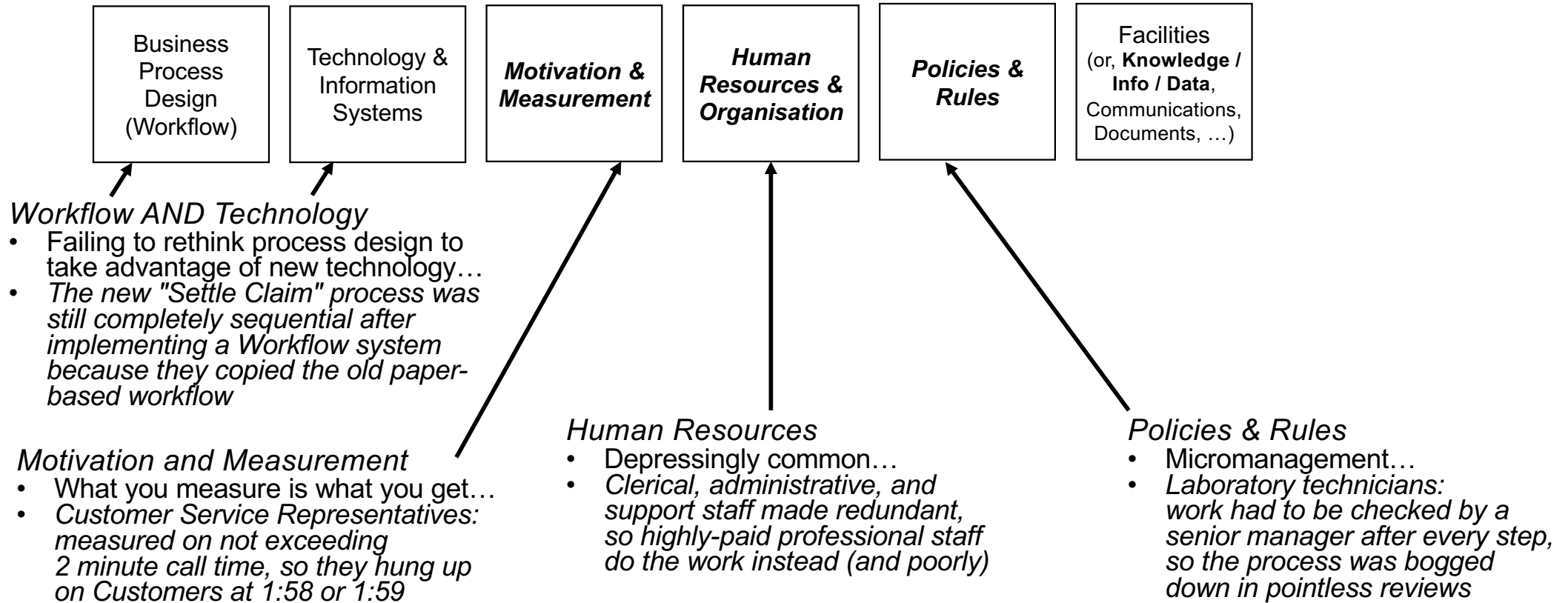

And an example from a utility – vilified in the media for disconnecting the heat of an 86 year old widow in the middle of the coldest weather in living memory:

- *Human Resources* – outsourced Customer Service Reps
- *Policies and Rules* – CSRs must escalate certain cases (pending disconnection) to utility
- *Motivation and Measurement* – outsourcer is hit with a financial penalty for every escalation!

Assessment by enabler – Business Process Design

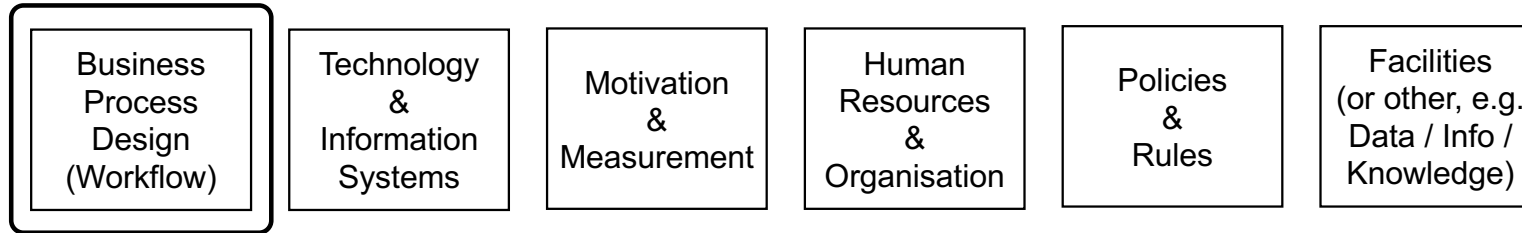

Assessment points:

- Too many actors or excessively granular activities?
- Non-value-adding or duplicated steps?
- Unnecessary intermediaries
- Steps excessively sequential or not performed in natural sequence?
- Confusing "inform" with "approve," leading to unnecessary delay?

Example:

- The paper-based **Settle Claim** process was highly sequential, involving many roles and many tracking and checking steps. The to-be process perfectly duplicated the as-is flow using a workflow engine!

A quote:

- "We have customised the process to meet every possible variation and need. Every instance is unique. Can we develop a baseline process that would meet *most* needs?"

Technology & Information Systems

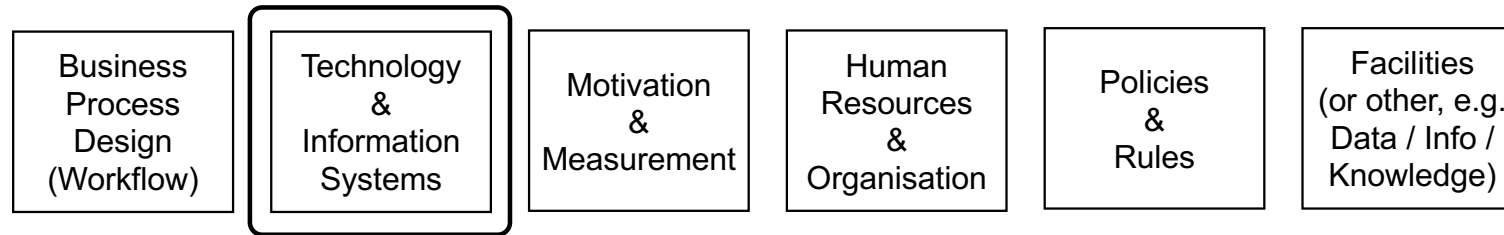

Assessment points:

- Unavailable information or redundant data re-entry?
- Missing functionality?
- Awkward interfaces?
- Lack of support for workflow?
- Not leveraging new technologies?
(Robotics, drones, AI, BPA...)
- Purchased software that is more complex than necessary

Example:

- Nurses in a **Regional Dialysis Program** were “supported” by multiple, dis-integrated applications, most externally hosted. They spent >50% of their work hours manually copying or “cut and pasting” data between applications.

A quote:

- "We are so 'last-century' – printing, scanning, sending, and emailing inaccessible information. The result – we have local 'information factories' of shadow systems and Excel nightmares."

Motivation & Measurement

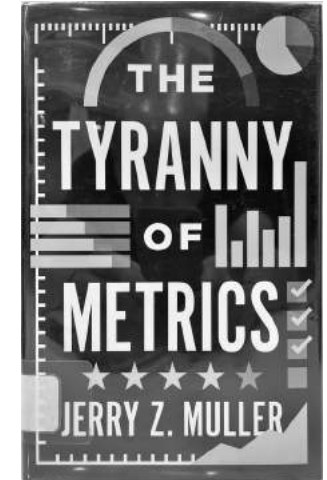
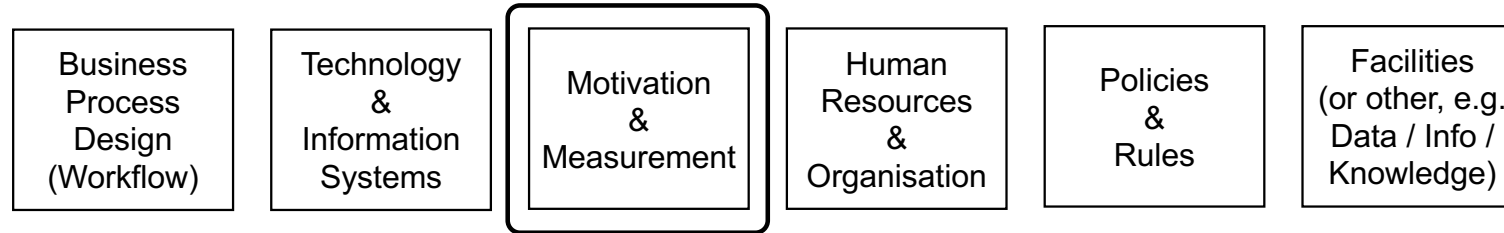

Assessment points:

- Inappropriate performer or process measures?
- Internal rather than customer focus?
- Measures of tasks vs. outcomes? (e.g., piecework)
- Simple measures that are easy to game vs. metrics (algorithms) that are hard to game?
- Rewards that work against the process? ("Perverse incentives")

Example:

- A major telephone company invested hugely in reengineering Customer Service “processes” to enable CSRs to up-sell and cross-sell, but left performance measures based on call time in place. The result – total failure.

A quote:

- "We reward our Quality Assurance people on the number of defects they discover. Naturally, they find a LOT of defects, and in some cases actually introduce them!"

Human Resources & Organisation

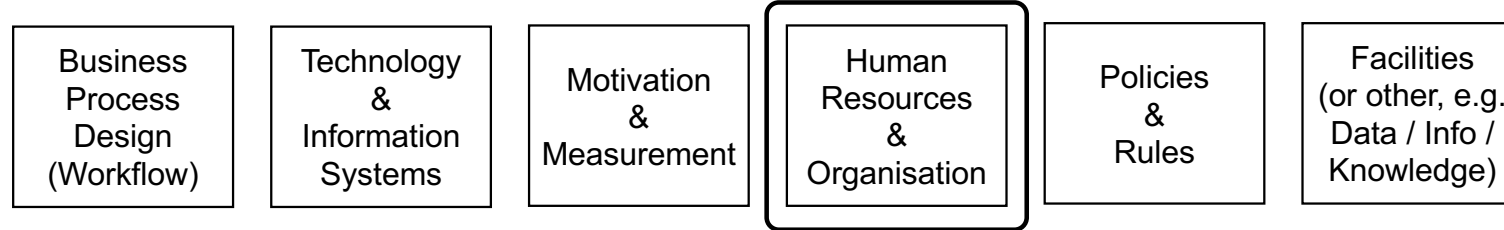

Assessment points:

- Mismatches between task value and performer?
- Too little empowerment?
- Fragmented jobs / roles?
- Recruiting for past needs?
- Roles needed to hold the process together – Expediter, Co-ordinator, Traffic Manager, ...

Example:

- A laboratory underwent major cost cutting and laid off many administrative and clerical support workers. Highly paid, scarce scientists then spent ~55% of their time on administrative tasks – *and they were not very good at them!*

A quote:

- "Our complex, decentralised, granular organisation structure and role definitions lead to a fractured process where no one feels responsible for the whole."

Policies & Rules

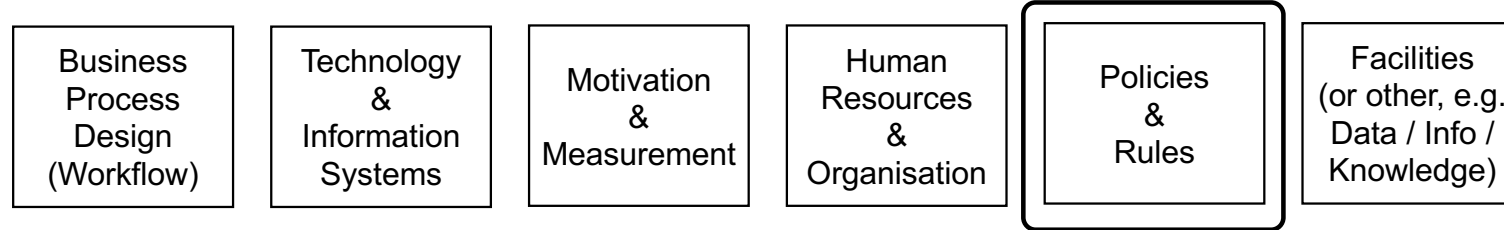

Assessment points:

- Out-of-date policies or numerical limits?
- Excessive review, inform, or approval steps?
- Inconsistent or conflicting policies
- “Anecdotal” policies
- Misinterpreted regulations

Example:

- For any policy change, a Property and Casualty Insurer required a document be signed at a broker's office and sent to their centralised Signature Verification Unit. This was of dubious value and is now a major bottleneck for a global company.

A quote:

- "All these 'wet signatures' may be a cultural need, not a legal need."

Facilities (or other)

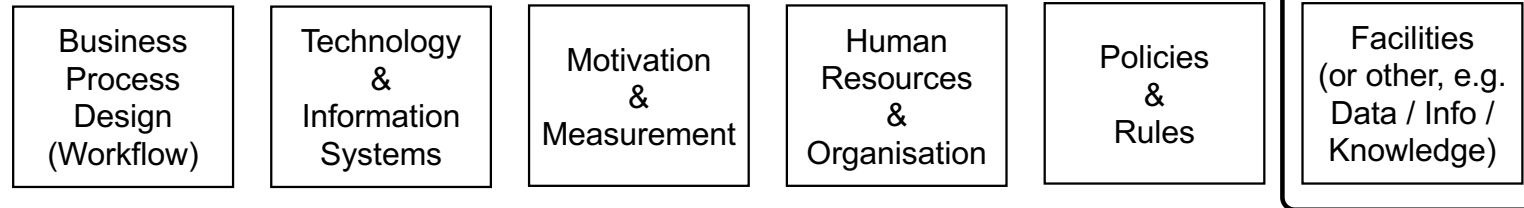

Assessment points:

- Mismatch of work needs and facility?
- No support for teamwork?
- Layout that impedes flow of work, people, or materials?
- Process design that optimises a facility, not the process?
- "Facilities flow" that bears no relation to the "workflow?"

Example:

- In a hospital, the location of units (Imaging, Toxicology, Cath Lab, ...) dictated a bizarre (*and risky!*) patient flow that took them through every floor and area of the hospital.

A quote:

- "Our in-person Customer Service area has two separated counter areas – essentially "Payments" and "Returns" – requiring two people to staff them, even in slow times. It's not so great when we're busy, either."

Conflict within an enabler

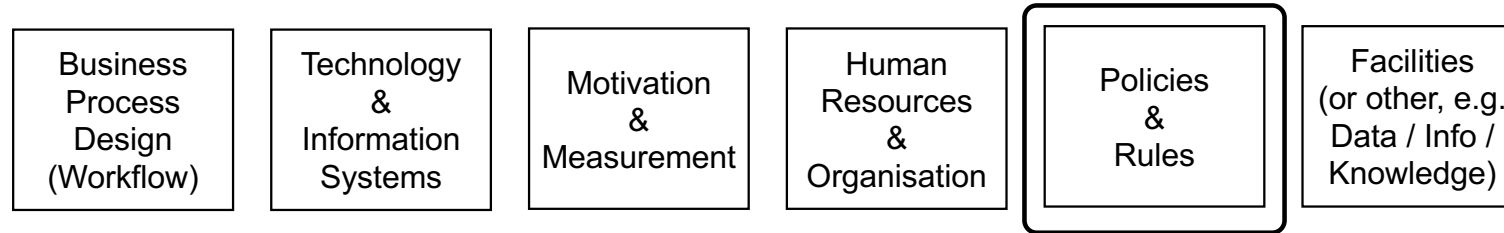

Contradictory policies, or "gaps and laps"

E.g., at a manufacturer of high-tech manufacturing equipment, the #1 problem was *inability to ship complete systems on time*

- Policy: Virtually no finished goods inventory of spare parts and consumables – "*overly Lean*"
- Policy: All orders for spare parts or consumables *must be* shipped within 24 hours
- *Outcome* – complete systems awaiting shipping were *cannibalised* for spare parts and consumables

Conflict between enablers

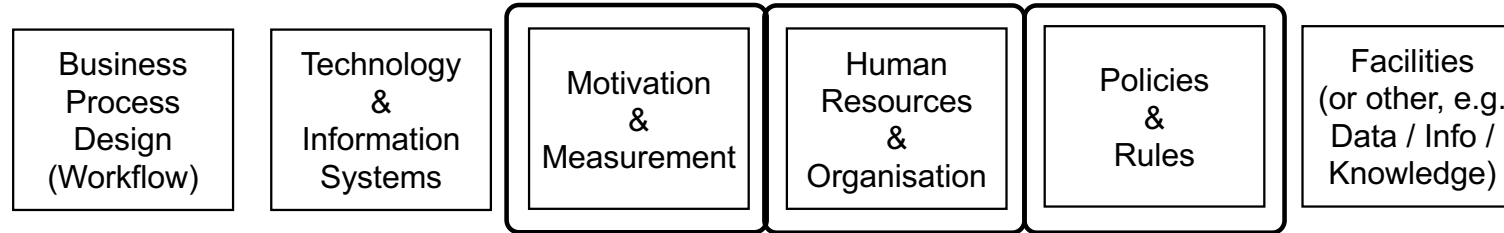

E.g., at a gas utility a staffing decision (HR), a policy, and a performance reward (punishment) collectively harmed the process

- HR – Outsourced Customer Service Reps to BPO provider
- Policies and Rules – Level 1 CSRs must escalate certain cases (e.g., disconnection) to Level 2 CSRs employed at the utility
- Motivation and Measurement – Outsourcer is hit with a *financial penalty for every escalation!*
- *Outcome* – Level 1 CSRs are penalised by BPO management for every escalation, so they learn to just abandon those calls

A problem in one enabler surfacing in another

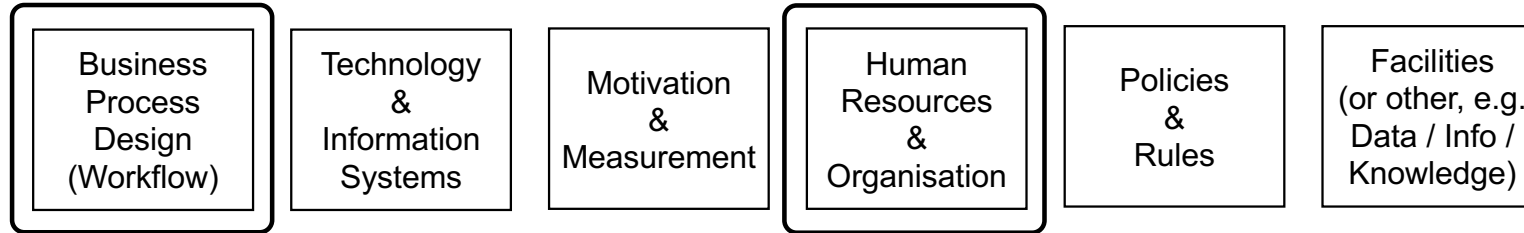

E.g., at a national Forensics Lab, a reclassified job definition led to fractured workflow:

- Police Officer submitting an Item met with Submissions Clerk
- Police Officer then had to go elsewhere meet with Customer Services to complete submission.

Why? Submissions Clerk role improperly reclassified, now lacks legal authority to accept evidence (the Item) – Police Officer sent to Customer Services who have legal authority to accept the Item even though it's *not their job!*

Assessment by Enabler generates ideas for the To-Be

Workflow:

- Resource not available to Requestor until after *all* classification and tagging is complete, even though:
 - it's unnecessary in many/most cases
 - it's freely available from US Library of Congress, British Library, etc.

(Future State – make Resource available immediately, then do classification and tagging only if necessary, first checking if other libraries have done it)

IT:

- Three separate core systems lead to manual copying of data from system to system, often through "shadow systems".

(Future State – automated data replication)

- Functional richness of core systems leads to overcomplexity

(Future State – identify the subset of features we really need, and only use those)

Assessment by Enabler generates ideas for the To-Be

Motivation & Measurement:

- Because work is so granular, no one is motivated by the performance of the whole, which is not even measured.

(Future State – develop relevant end-to-end metrics, and develop role and workgroup metrics to assess our impact on professional staff)

Human Resources:

- Acquisition tasks don't require a skilled, higher cost Records Manager – Agency staff could do much more, RMs could do higher value work.

(Future State – Assign authority for higher-value work to Agency staff)

Policies & Rules:

Three (3!) approvals required for low-value (€20 - €50) cases

Future State – revise policy to reduce approvals, eliminate them entirely for low-value cases

Closing thought on the value of a framework,

Give people a framework, go through it point-by-point, and they will *quickly* identify factors that would have been *missed*.

Policies + Rules SAP

- "Policy" seems to require approvals (3) for low-value cases (€200, - €50) or are covered by Collection Development Policy
 - BA Manager
 - Subject Specialist
- "Four eye" approval is required by ~~EU~~ EU law, but perhaps can be simplified (e.g. use ISIS)
- Unlike many libraries, we don't have a cataloguing policy that defines where we put skilled resources + time.
(but it's in the works)
 - ~~prevents~~ prevents sharing data between ECB and externally-hosted app (Alma)
- IT (external system should not access internal system, for good reason)
 - ~~Alma provides equal info access~~ Alma provides equal info access
 - Separate systems - Alma, SAP, Darwin
 - Leads to manual duplication
 - Orders in Alma + SAP
 - ~~invoices~~ Alma + Darwin LRF
 - (info starts in Darwin, manually to → Alma)
- Functional richness of Alma may lead to overcomplexity (using features we don't really need) STAPLES

De-facto policy Library IT Division

Human Resources

- Complex ~~pan~~ system (Alma) requires certain skills, and constant skills upgrading due to continual evolution of system.
- Mismatch between task value and performer e.g. Acquisitions steps are administrative, and don't require ~~the~~ skilled librarian.
- Some Agency Staff could be empowered to take on more responsibility.
- Large increase (+1000) in ECB staff in last year, library staff level unchanged

Motivation & Measurement

- Salary
 - Good user feedback
 - we capture some feedback in Customer Sat. Survey
 - ~~we capture~~ we capture some feedback
- *Note - we are benchmarking our staff levels against other EU central banks*
- Because the work is so granular, no one feels motivated ~~to~~ by the performance of the whole, and the feeling professional skills are not being used.
- Would like to compare acquisitions - Loans - CDP

key objectives

M: M (cont.)

(CDP - breadth of subjects + depth of collection by subject + format (print, online, ...))

- Also measure impact of Library Collection on publications by ECB staff
 - in ECB jobs, look for citations of material in collection
 - + interview author on effectiveness
- positive results
- We don't have efficiency measures
 - where is resource effort applied? (e.g. ~~print~~ consumes time...)
- Facilities
 - (new facilities a big improvement)

Assess by enabler, establish 5-10 to-be features, assess each feature by enabler

Goal or
issue, not
rigorously
specified

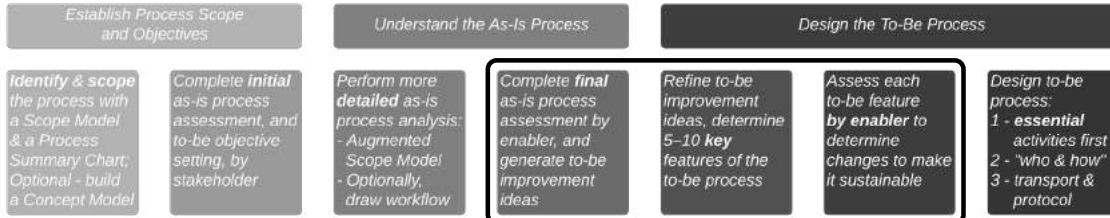

A feature is a significant change or improvement to the process, or a significant factor in the design of an all-new process.

Enabler-based assessment of the as-is process generates ideas for the to-be process.

	Assessment:	Features:
Motivation & Measurement	Sales Reps motivated entirely by commission, with no motivation to return and submit Service Orders	Increase Rep's commission for early submission New Sales Assistant role to enter Service Orders
Human Resources	Order Capture and Order Submission are not effective uses of a Sales Rep's time	Service Order entry directly by Customer New Sales Assistant role to enter Service Orders

Rejected by execs. A feature.

Another feature.

Same feature again.

Then, assess each Feature – what changes are needed, enabler by enabler, to make this feature work?

Feature	Process Design	Info. Systems & Tech.	Motivation & Measurement	Human Resources	Policies & Rules	Facilities (or other)	Feasibility & Notes
Direct Service Order entry by Customers	Need to get the Service Order from the server to the Engineering Supervisor for assignment, and then to Engineer for assessment Customer review?	Obviously, all the Web stuff Integrated Service Order DB Workflow functionality? What format for Customer sketches?	Commission? What impact on commissions for current sales force?	Displacement of current Sales Reps? What are expectations for freed-up Sales Rep time? Customer training?	Will all Customers have access to this?	Electronic orders may free up space currently used for bins, boards, etc..	Highly feasible. What will Customer and Sales Rep reaction be?

Avoids unanticipated consequences!

Determine key features of the to-be process

All the phases so far have generated to-be ideas – 50, 100, or more ideas. *Now what?!*

You could do a formal assessment, idea by idea.

I'm not a fan, but some organisations like *the numbers*.

Idea	Good for Customer 1 - 3 (best)	Good for Performers 1 - 3 (best)	Good for the Enterprise 1 - 3 (best)	Ease of Implementation 1 - 3 (easiest)	Total
SPOC (Single Point of Contact)	2	2	3	3	10
...	

Instead, rely on the group's:

- ability and desire to *seek consensus*
- *collective knowledge & experience* from working through the first four phases (*remember – don't skip any!*)

We'll use *brainwriting* to synthesise 5 – 7 features from the many *ideas*

Use "brainwriting" – "big wheel, little wheel" facilitation

- Generates *more* ideas, and more *diverse* ideas
- Easier for *everyone* to make their contribution

2. Each participant "brainwrites" ideas, each on a separate Post-it or Lucidchart "Sticky Note". Aim for ~5 – 7.

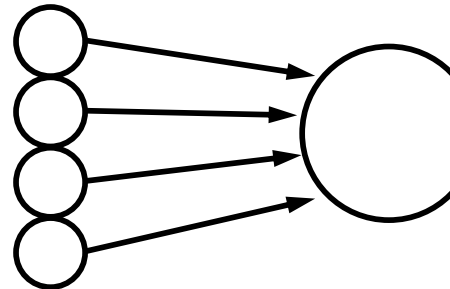
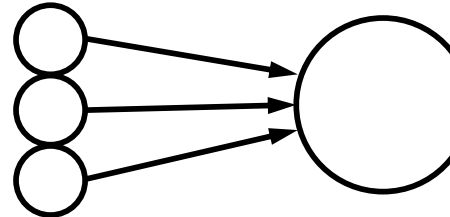
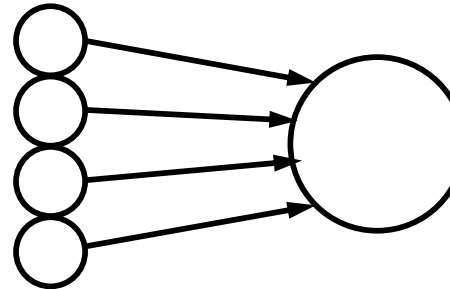
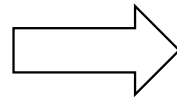
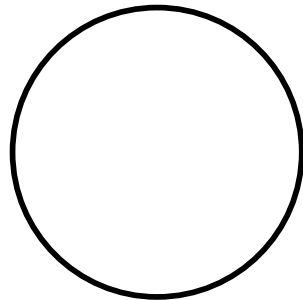

3. Small groups synthesise ideas into a "team effort" (again, ~5 – 7) then present to entire group.

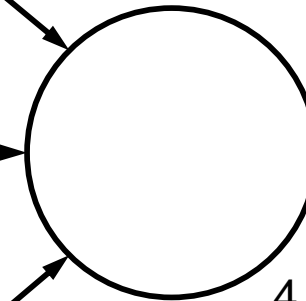

1. Facilitator gives question or instruction to entire group (11 participants, in this case.) "Let's each identify the key features of our new process."

4. Entire group synthesises ideas into a group effort, ~5 – 7 *features* (rarely more than 10)

Example – determining features of the to-be process

Synthesis of features from group suggestions...

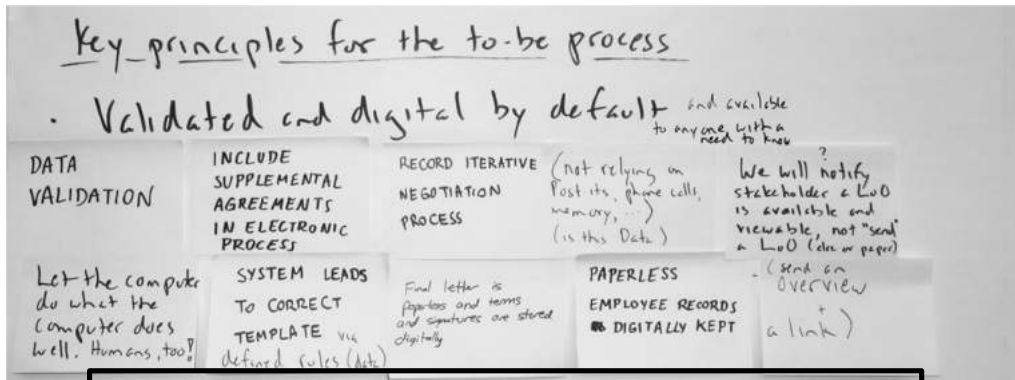

Ideas from the smaller groups...

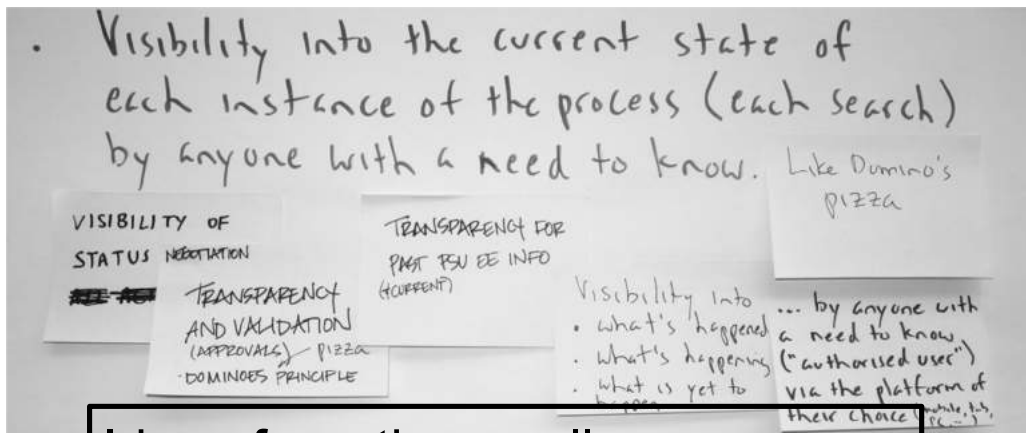

Ideas from the smaller groups...

Five of seven features determined by the team

1. Data digital by default, validated and captured at source, and suitable for all downstream use.
2. Visibility into the current state of each instance of the process (each faculty search) by anyone with a need to know.
3. Separate the “need to approve” from the “need to be informed.”
4. Each search will follow a defined and visible workflow.
5. *The process will be designed for digital signatures **only** – no fallback!*

Same example using a virtual whiteboarding tool

Lucidchart / Lucidspark, Miro, or even Google Jamboard are perfect for a brainwriting session like this.

Data digital by default,
validated, captured at source,
suitable for all downstream use.

Data
validation!
(Immediate!)

Let the computer
do what it does
best.
Humans too!

Record
negotiation
process in data
- not Post-its,
phone calls,
memory, ...)

System leads to
correct template
via defined rules
in data

Final offer is
paperless, with
terms and
signatures
stored digitally

We will notify a
stakeholder an
offer is viewable,
not "send" it
electronically or
on paper

Paperless
records digitally
kept

We will send an
overview and a
link, but not the
offer itself

Features usually focus on one enabler, but involve all

Reminder:

A *feature* is a significant *change (improvement)* or *factor* in the design of a new process.
Often implemented one at a time.

Intent:

- "Don't sweat the small stuff" – focus on significant ideas.
- Avoid "Big Bang" implementations – implement feature-by-feature

Assessment by Enabler (and other techniques) generates ideas – some become *features*:

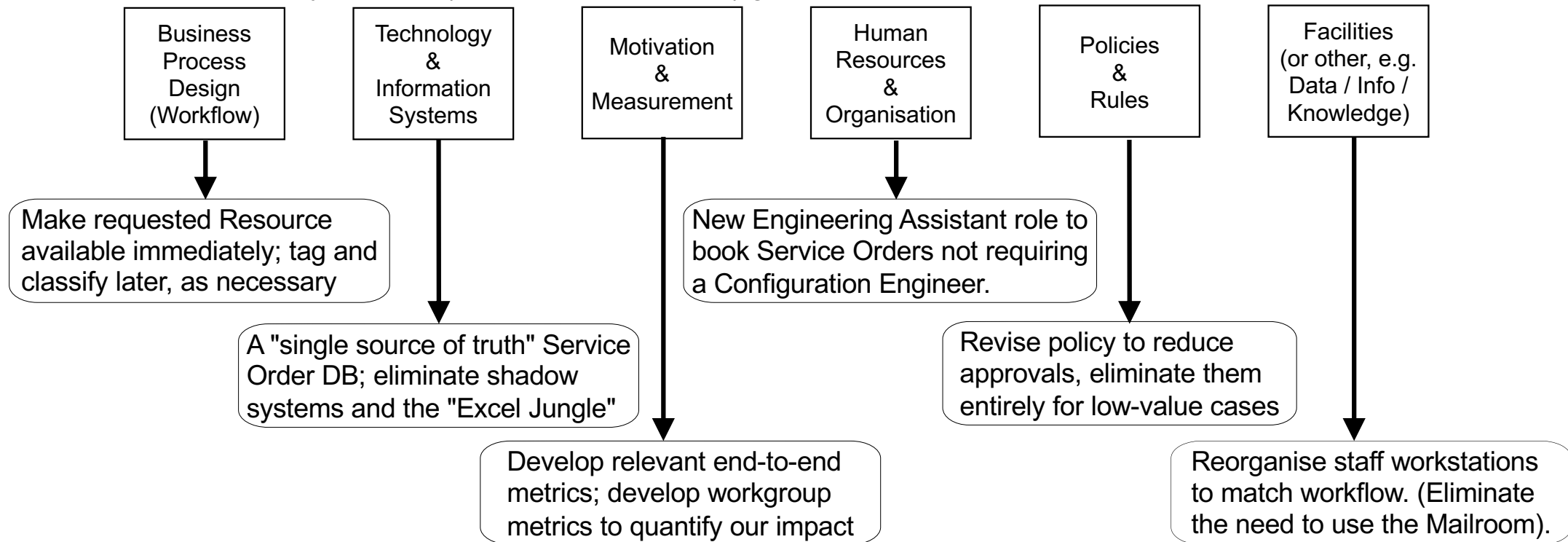

A bit more on assessing each to-be feature, enabler by enabler

Intent:

- Ensure each feature is *implementable* and *sustainable*
- Avoid *unanticipated consequences* through a holistic assessment

For each *feature*, ask...

"What needs to change in *this specific enabler* to make this *feature* work?"

***Changes in multiple enablers are usually needed for each feature.

Feature	Process Design	Info. Systems & Tech.	Motivation & Measurement	Human Resources	Policies & Rules	Facilities (or other)	Feasibility & Notes
<i>Assign authority for higher-value work to Support Staff rather than having it all done by Senior Records Managers.</i>	Need to decide whether we can auto-route requests to the appropriate staff member, or if all should go to a Senior Records Manager for routing	Current systems are much too complex for most cases, especially the ones that would now go to Support Staff. Need to isolate and only display essential functions	We MUST adjust the performance measures of Support Staff to ensure they are not penalised for taking on additional responsibility	Revise job descriptions for Support Staff as necessary. Provide additional training in Records Management functions and the RM System	Current policies dictate that all categorization and classification work be carried out by Records Managers – this will have to change. Some regulations may be a factor	Some Support Staff will be moved closer to Records Managers, but this is a minor change	Highly feasible if we can resolve Policy issues. Support Staff are very positive about the opportunity, and Records Managers look forward to more time for high-value work.

This feature required change in *all six* enablers, especially M&M and P&R!

A richer example – first, describe the feature (page 1 of 2)

A surprise benefit – invaluable during training and roll-out.

Feature name (A feature is a particular characteristic or improvement in the to-be process)
Forensic strategy (“applying science at the front end”)
Description
<p>A Senior Scientist, typically the Case Manager, will meet with the Submitting Officer and develop a case strategy specifying which avenues of investigation, and which items and tests are most likely to yield the needed results in the least time with the least effort. The goal is to do this for as high a percentage of cases as possible.</p> <p>This is the first decision point in another characteristic, <i>multiple decision points</i>.</p> <p>Visually, this is the first stage in a funnel, in which the work being performed on a case is continually reduced as new facts arise.</p>
Issues addressed
<p>There is a tendency for the Customer (the police) to submit all possible items, and request all possible tests, or at least submit more items for more tests than are necessary or justified. This is known as “forensicating” a case and is ironically a primary cause of the delay and expense that the customer is unhappy with.</p> <p>Currently, Forensics accepts all items and performs all requested tests through to completion. In some cases, the suspect has become the accused and then the defendant, and has been convicted and incarcerated, yet testing continues.</p>
Anticipated outcomes / benefits
<p>For the Customer – deliver a positive result in less time, at less cost.</p> <p>For Forensics – free up resources by reducing submissions, and performing fewer tests on fewer items, thereby providing better throughput for all cases.</p> <p>In the future, Forensics will only perform those tests that will help, and which will stand up in court because we can say “we chose these tests for these reasons.”</p> <p>On an ongoing basis the customer will become more aware of the avenues that are most effective.</p>

Then identify requirements to implement each feature (page 2 of 2)

Eight features assessed in a single five-hour session!

Enablers	
Process Design	<p>Performers (“actors”), tasks, sequence, dependency</p> <ul style="list-style-type: none"> <input type="checkbox"/> Senior scientist “meets with” appropriate scientist, not necessarily in person <input type="checkbox"/> Assessment and agreement and recording of <i>requirement</i> which is not contracted yet. <input type="checkbox"/> The requirement must be made available to the Process Manager, who will assess it with respect to current capacity. <input type="checkbox"/> The Case Manager and Process Manager will then negotiate and refine the requirement. They will then agree on “what and when” and commit capacity, which might involve another provider.
Information Systems & Technology	<p>Systems, automated support, data and Information, comm.</p> <ul style="list-style-type: none"> <input type="checkbox"/> Capture requirement <input type="checkbox"/> Real-time view into work-in-progress and committed capacity (Forensics' and subcontractors)
Motivation and Measurement	<p>Measurement, assessment, consequences</p> <ul style="list-style-type: none"> <input type="checkbox"/> The Process Manager will be measured on accurately estimating capacity and throughput. <input type="checkbox"/> The Process Manager makes a commitment for Forensics, and will be measured on having done the least to get the necessary result. (“lean consumption”)
Human Resources	<p>Recruitment, placement, education, roles, matching task to role</p> <ul style="list-style-type: none"> <input type="checkbox"/> New front-end role for scientists <input type="checkbox"/> Process Manager role <input type="checkbox"/> Provide service 24x7 will impact some staff. <input type="checkbox"/> Recruitment, recognition, and reward are fundamental to making this work
Policies and Rules	<p>Internal: policies & guidelines. External: laws and regulations</p> <ul style="list-style-type: none"> <input type="checkbox"/> The overall submissions policy must be revised to reflect forensic strategy vs. “take it all.” <input type="checkbox"/> Investigate legal consequences of forensic strategy. <input type="checkbox"/> Mechanism to protect the individual scientist from pressure. (“Forensics, not the individual scientist” – this is a corporate decision, not a personal decision) <input type="checkbox"/> Scientists can't make commitment without the Process Manager. <input type="checkbox"/> A 10 minute phone call and a 4 hour conference both constitute delivery of a service. A request to confer with a Case Manager constitutes contract initiation.
Facilities and Equipment	<p>Physical accommodations, layout, equipment, furnishings</p> <ul style="list-style-type: none"> <input type="checkbox"/> Some place to meet – in person, teleconference, ...

Design to-be process – overview

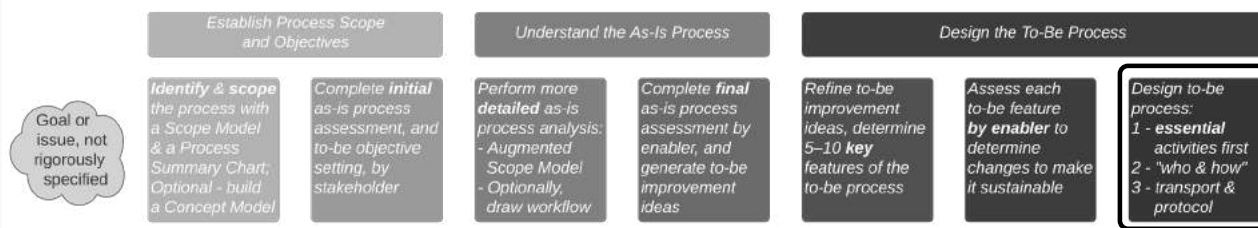

Goal or issue, not rigorously specified

- Use an Augmented Scope Model to determine what the essential activities are
- Next, factor in who will perform each activity, then how
 - a person as a manual activity
 - a person interacting with a system, e.g. a use case
 - a system, e.g., RPA (Robotic Process Automation)
- Link essential activities by dependency – a PERT chart
- Adjust – e.g., verify activity is assigned to the correct role
- Only then redraw as a swimlane diagram
- *Finally*, add non-value-added but necessary activities:
 - transport, record keeping, notification, etc.
 - ensure any approval steps are *really* necessary ("Don't confuse notification with approval.")

Key points:

- As with the as-is process – "*What first, who and how later*"
- Design around *essential* steps, not *administrative* steps

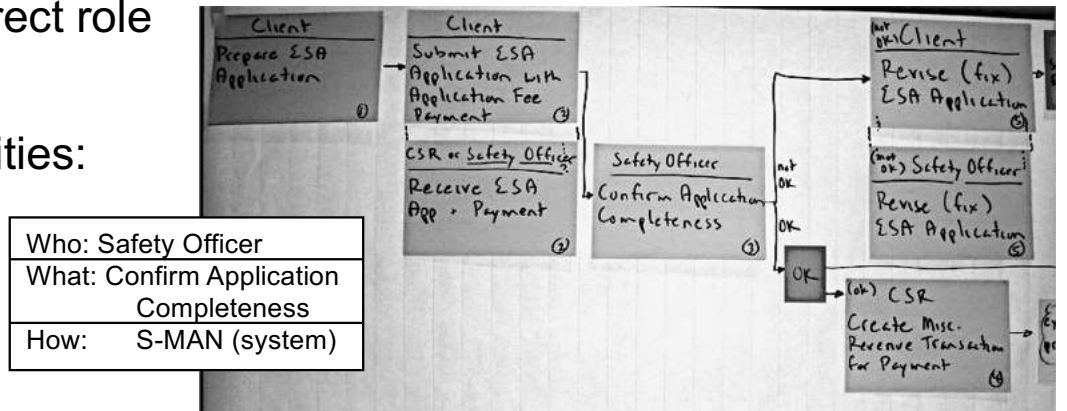
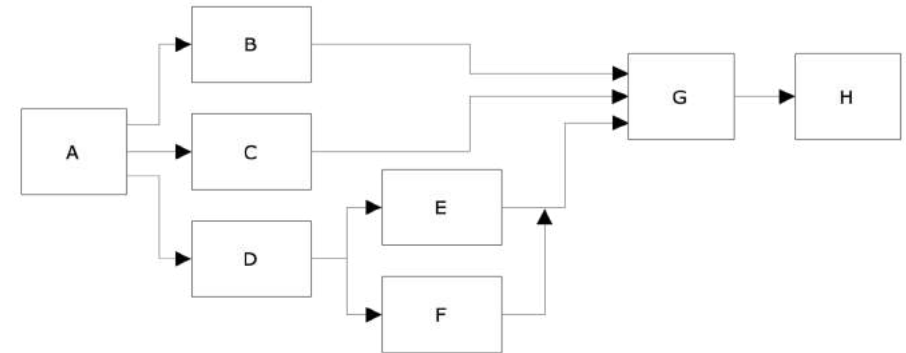

4 – Design to-be process – the details – Identify essential activities

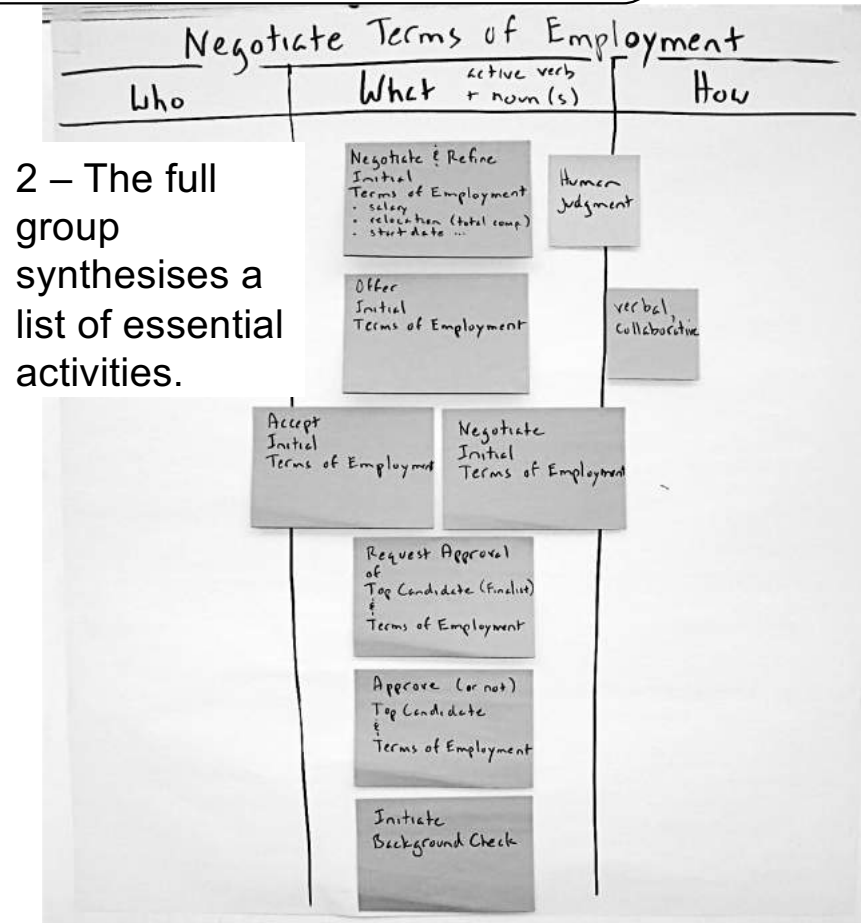
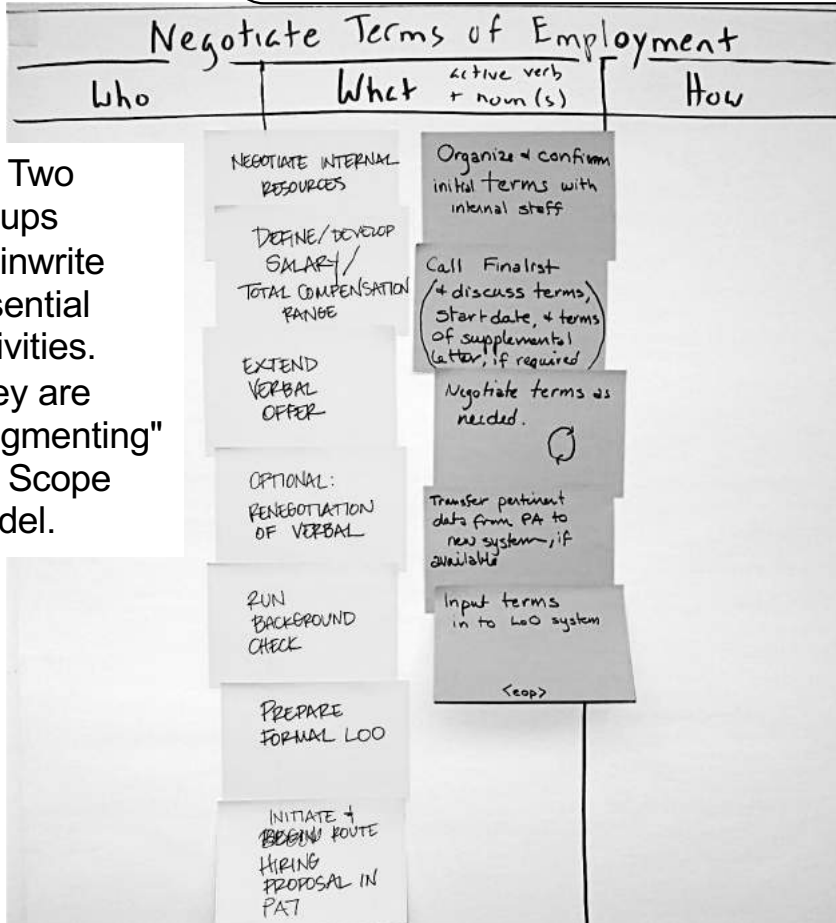
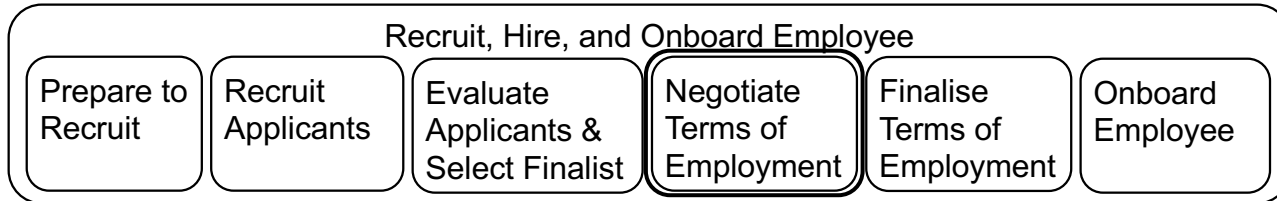

Lucidchart version



Similar example – Augmented Scope Model for the full process

Recruit, Hire, and Onboard Employee



- For the first time, the end-to-end process is visible
- A surprise to everyone how much work it is
- Still no reference to “who or how” – just “active verb + noun”
- This is critical to build support for change – it “depersonalises” in a good way!

For each essential Activity, add "Who," "How," and lots of "Notes"



- We have the core of the to-be process design
- Going immediately to a Swimlane Diagram would be *overwhelming!*
- But now, developing the to-be flow model (swimlane diagram) is straightforward – *We Can Do It!*
We have:
 - actors (swimlanes)
 - steps
 - how the steps will be done
 - sequence
(approximate, but OK for now)

Final observations from session retrospective, 12 people

- Session retrospective 1/2
- The steps we went through, and starting @ high level, "opened up minds"
 - This ^{core} group could be kept together ^{for future process work} as we understand the method, etc. but others join in based on topic
 - Selection of a group that is open-minded about change was effective.
 - Use of visible flipcharts helped, and could be helpful/interesting to other staff
 - The group was the right size (not too big)
 - It was good to have a group with some "distance" from the current process; current "owners" may not be happy, and will have to be brought on board (we've represented their resistance, though)
 - Pulling back to the high level (scope model) enabled us to make the progress we did.

- 2/2
- Having enabler assessments (eg Policy) addressed and visible enabled us to "let it go" and lay out new workflow.
 - Without high level, it's easy to get into the weeds.
 - Specifically addressing the perspective of each stakeholder was a beneficial because it changed our thinking.
 - This process (Print Pub) can be a catalyst for major change
 - Helpful to have a facilitator - "ignorance is golden"

Final thoughts from session retrospective

- The steps we went through and starting at the high level “opened up minds.”
- Use of visible flipcharts helped, and could be helpful / interesting to other staff.
- Pulling back to the high level (Scope Model) enabled us to make the progress we did.
- Having enabler assessments (e.g., Policy) addressed and visible enabled us to “let it go” and lay out new workflow.
- Without the high level, it's easy to get into the weeds.
- Specifically addressing the perspective of each stakeholder was beneficial because it changed our thinking.
- Helpful to have a facilitator – “ignorance is golden.”

Every phase contributes to the goal – don't skip any!

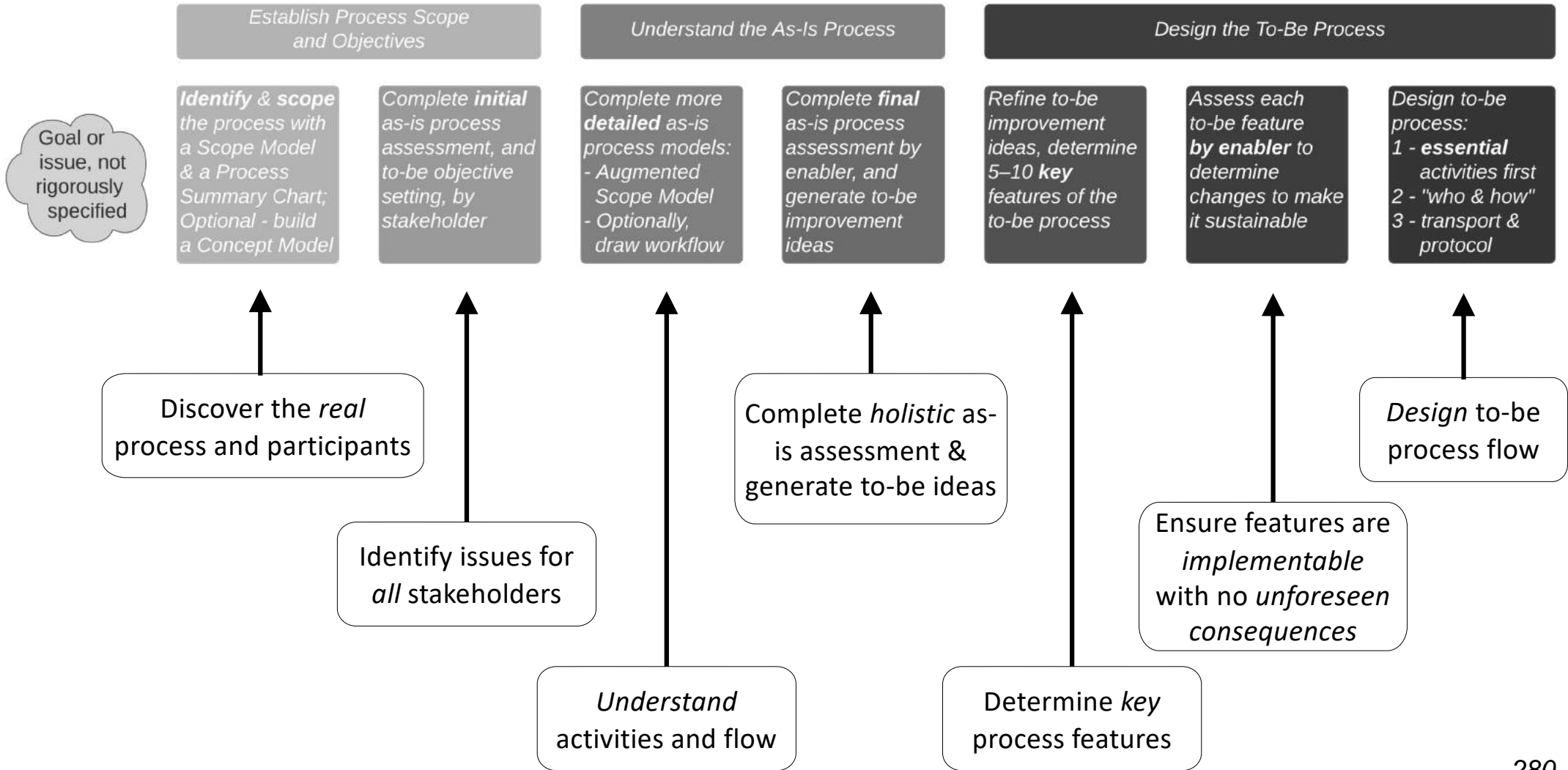

Remember – "It's a process!"

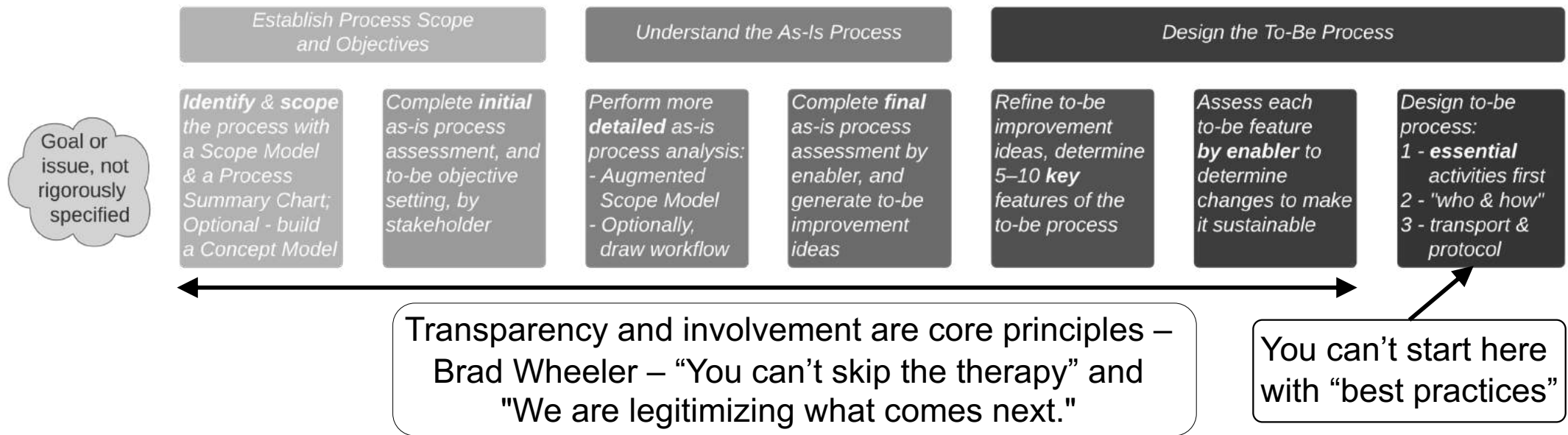

Making the new process sustainable:

- Alignment of *all* enablers, especially *Motivation & Measurement*, *Human Resources & Organisation*, and *Policies & Rules*
- Visibility of the process – the *whole* process, right down to *job aids*
- *Training* in the new process for current and new staff
- Time for *each feature* of the new process to *take hold* before more change – *continuous* change should mean *regular* but not *constant* change

Phase 1 summary – Discover processes, “frame” the target process

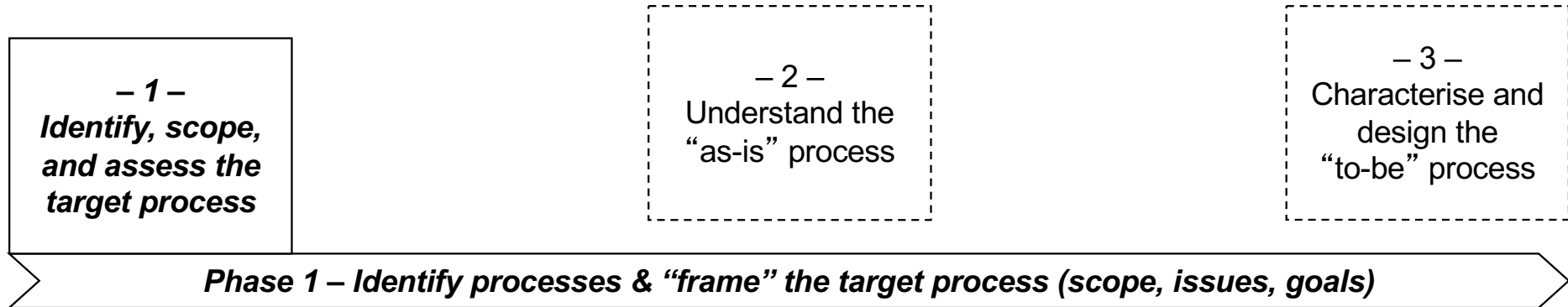

Identify a set of related processes	Select target process and define “what” (essential scope)	Define as-is process “who and how”	Determine why process must change – “Case for Action”	Specify to-be process goals – “Process Goals” and Differentiator	Specify to-be process performance metrics
<ul style="list-style-type: none"> • ID common terms • Select core nouns (things) • ID activities acting on things • Link activities into processes • Draw <i>Process Landscape</i> 	<ul style="list-style-type: none"> • <i>What – TRAC:</i> • Triggering event • Results by stakeholder • ~5 +/- 2 main Activities • Cases / variations • Draw <i>Process Scope Model</i> 	<ul style="list-style-type: none"> • <i>Who –</i> Functions / Organisations / each Actor (optionally main responsibilities) • <i>How –</i> supporting Mechanisms • Draw <i>Process Summary Chart</i> 	<ul style="list-style-type: none"> • Stakeholder issues and concerns • Business context (changes in the environment) • Consequences of inaction • Record <i>Case for Action</i> 	<ul style="list-style-type: none"> • Establish subjective goals by stakeholder • Establish objective (measurable) goals • Clarify differentiator • Record <i>Process Goals</i> 	<ul style="list-style-type: none"> • Determine basic <i>measures</i> • Craft process <i>metrics:</i> <ul style="list-style-type: none"> • strategically aligned • outcome-based • customer-focused.

Phase 2 summary – Model and understand the as-is process

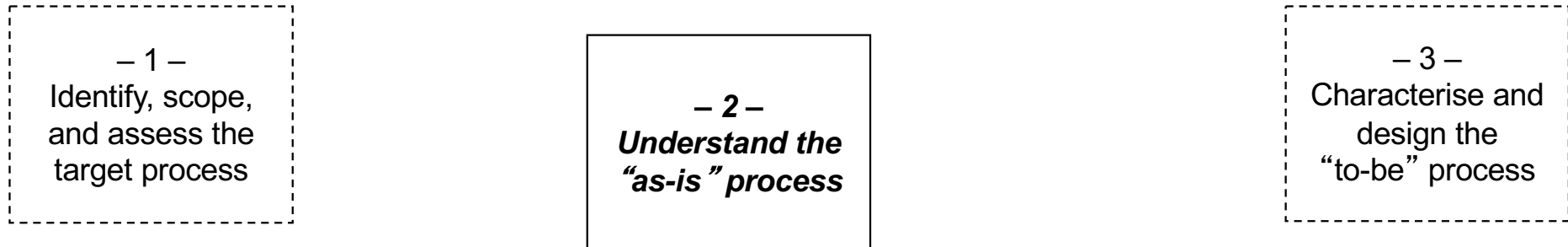

Phase 2 – Model and understand the as-is process, and impact of all enablers

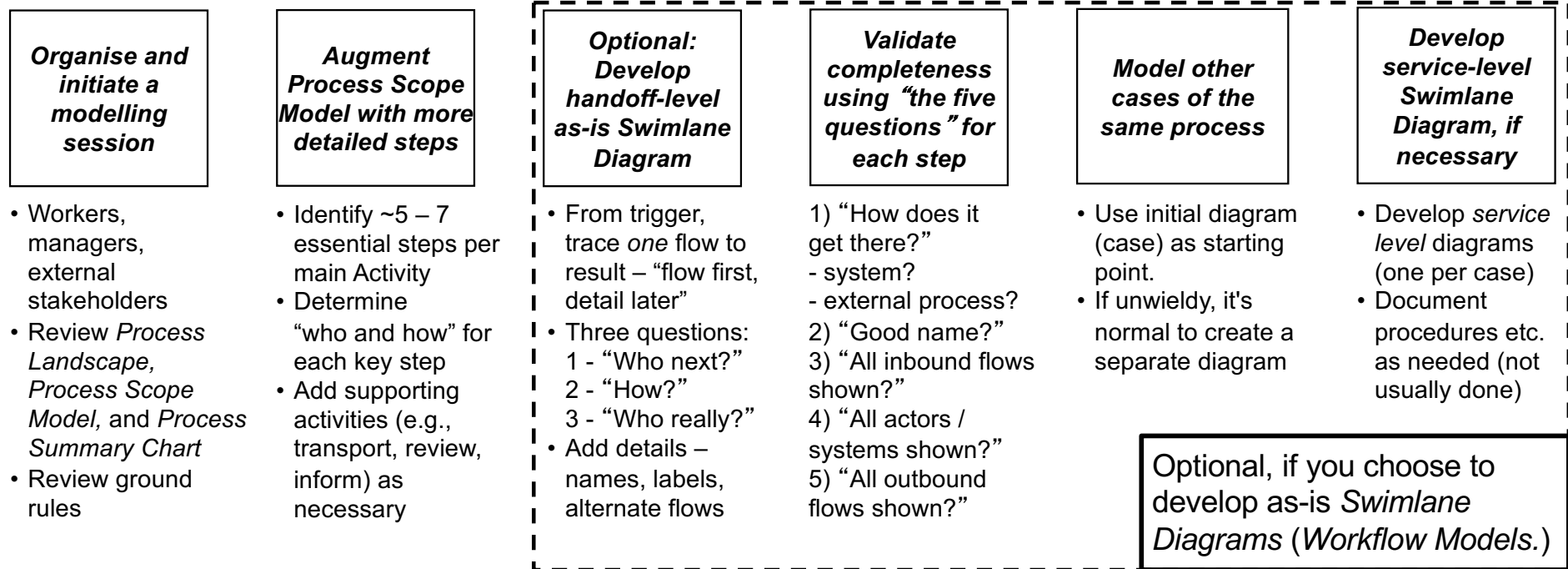

Phase 3 summary – Define to-be process characteristics and design

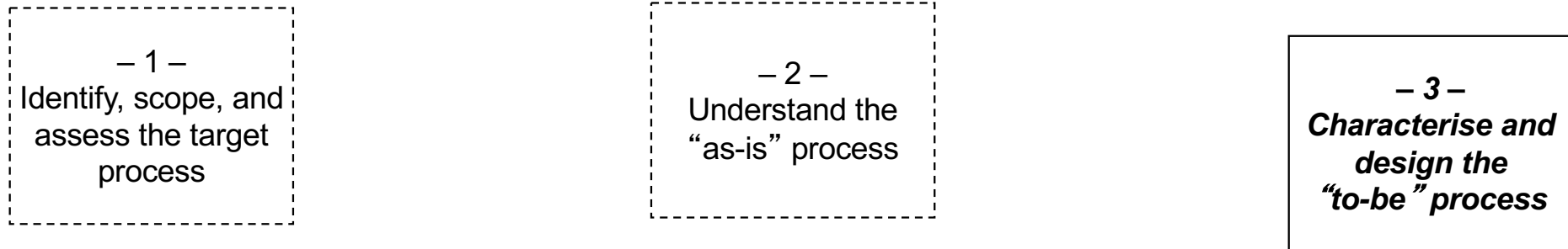

Phase 3 – Assess as-is process, develop to-be characteristics, design to-be

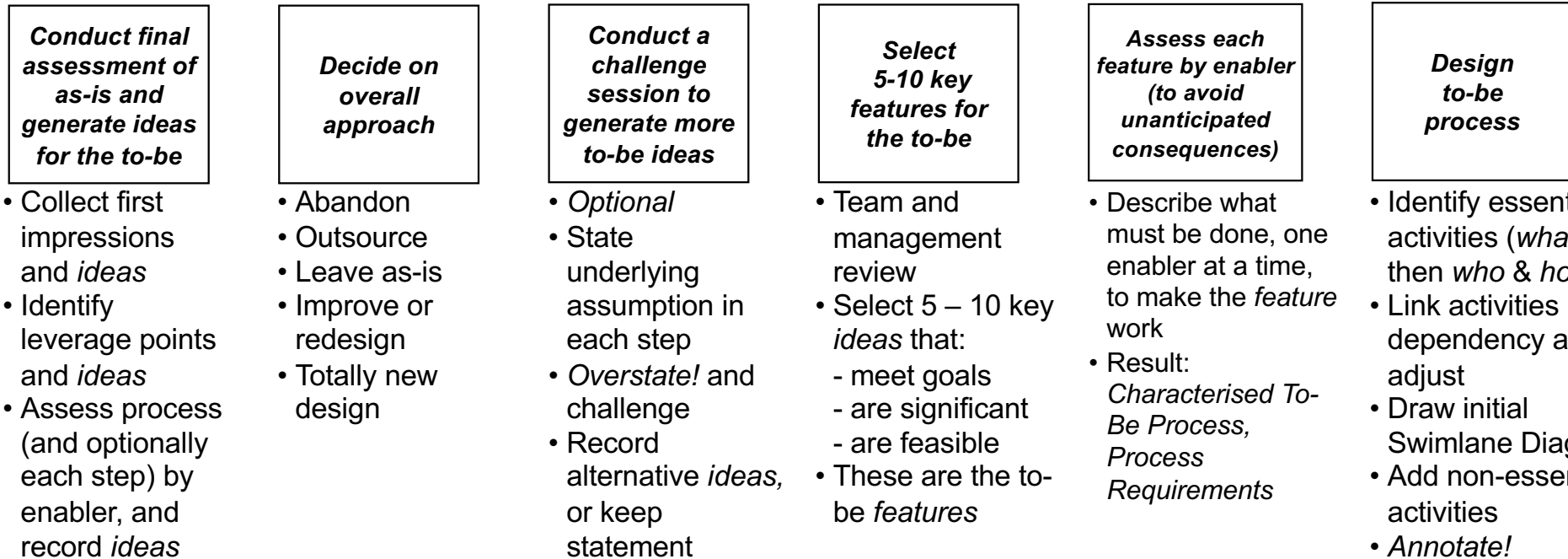

Conduct final assessment of as-is and generate ideas for the to-be

- Collect first impressions and *ideas*
- Identify leverage points and *ideas*
- Assess process (and optionally each step) by enabler, and record *ideas*

Decide on overall approach

- Abandon
- Outsource
- Leave as-is
- Improve or redesign
- Totally new design

Conduct a challenge session to generate more to-be ideas

- *Optional*
- State underlying assumption in each step
- *Overstate!* and challenge
- Record alternative *ideas*, or keep statement

Select 5-10 key features for the to-be

- Team and management review
- Select 5 – 10 key *ideas* that:
 - meet goals
 - are significant
 - are feasible
- These are the to-be *features*

Assess each feature by enabler (to avoid unanticipated consequences)

- Describe what must be done, one enabler at a time, to make the *feature* work
- Result: *Characterised To-Be Process, Process Requirements*

Design to-be process

- Identify essential activities (*what*), then *who & how*
- Link activities by dependency and adjust
- Draw initial Swimlane Diagram
- Add non-essential activities
- *Annotate!*

Three phases – summary

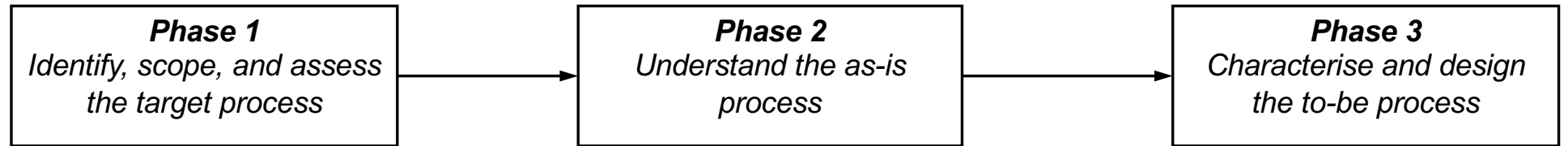

- **Identify related processes**
 - identify and link activities
 - 1:1 links are in same process
 - draw *Process Landscape*
- **Use TRAC to clarify target process' scope**
 - Triggering event
 - Result for each stakeholder
 - ~5+/- 2 main **Activities**
 - Cases (main variations)
 - draw *Process Scope Model*
- **Clarify as-is process elements**
 - functional areas
 - actors and responsibilities
 - systems and mechanisms
 - draw *Process Summary Chart*
- **Assess as-is process by stakeholder** (initial assessment)
 - also specify context and consequences of inaction
- **Specify to-be process goals**
 - subjective and objective
- **Specify performance metrics**
 - customer-focused outcomes, not internal task efficiency

- **Organise and initiate session**
 - staff and management plus external stakeholders
 - review scope, issues, goals
 - review ground rules
- **Build Augmented Scope Model**
 - Identify main steps by Activity
 - Identify who & how per step
- **Build as-is swimlane diagram**
 - **Optional**
 - one case and path at a time
 - Three questions:
 - “Who next?,” “How does it get there?,”
 - “Who really gets it?”
- **Check each step - 5 questions**
 - Verify all flows in and out
 - Confirm active, accurate name
 - Confirm all actors / systems
- **Model other process cases**
 - create new diagram, or use original case as a starting point
- **Add additional levels of detail**
 - *only if necessary*

- **Assess as-is process by enabler** (final assessment)
 - using as-is models as a guide
 - record ideas for to-be
- **Decide on approach** (abandon, outsource, leave as-is, improve or redesign)
- **Conduct challenge session**
 - challenge hidden assumptions
 - record ideas for to-be
- **Eliminate infeasible ideas** (cost, legal, resources, impact, ...)
- **Select 5 – 10 key ideas – these are the to-be “features”**
- **Assess each feature by enabler**
 - helps us *avoid unanticipated consequences*
 - builds Process Requirements
- **Identify & sequence essential activities**
- **Lay out to-be workflow**
 - handoff then service
 - only then add non-essential steps

Other courses for analysts by Alec Sharp

Working With Business Processes – Process Change in Agile Timeframes 2 days

Business processes matter, because business processes are how value is delivered. Understanding how to work with business processes is now a core skill for business analysts, process and application architects, functional area managers, and even corporate executives. But too often, material on the topic either floats around in generalities and familiar case studies, or descends rapidly into technical details and incomprehensible models. This workshop is different – in a practical way, it shows how to discover and scope a business process, clarify its context, model its workflow with progressive detail, assess it, and transition to the design of a new process by determining, verifying, and documenting its essential characteristics. Everything is backed up with real-world examples, and clear, repeatable guidelines. *Our most popular workshop!*

Business-Oriented Data Modelling – Useful Models in Agile Timeframes 2 days

Data modelling was often seen as a technical exercise, but is now known to be essential to other initiatives such as business process change, requirements specification, Agile development, and even big data, analytics, and data lake implementation. Why? – because it ensures a common understanding of the things – the entities or business objects – that processes, applications, and analytics deal with. This workshop introduces concept modelling from a non-technical perspective, provides tips and guidelines for the analyst, and explores entity-relationship modelling at contextual, conceptual, and logical levels using techniques that maximise client involvement.

Advanced Business Process Techniques – Aligning Process Work with Strategic, Organisational, and Cultural Factors 2 days

We regularly hear about the importance of “alignment” in achieving success when working with business processes, but alignment with what? This workshop provides specific, repeatable techniques to help your business process initiatives align with human factors, organisational culture, and enterprise strategy and goals. Rather than save these concerns for a single “think about people, culture, and strategy” phase, it shows how to incorporate them at every stage, from process identification, scoping, and initial assessment through to modelling, analysis, and design. Regularly receives rave reviews.

Business-Oriented Data Modelling Masterclass – Balancing Engagement, Agility, and Complexity 3 days

This highly interactive workshop combines the core content from two popular data modelling offerings by Alec Sharp – “Business Oriented Data Modelling” and “Advanced Data Modelling.” The first day of the workshop gets both new and experienced modellers to the same baseline on terminology, conventions, and unique, business-engaging approaches. The next two days provide intense, hands-on practice with more advanced situations, such as the enforcement of complex business rules, handling recurring patterns, satisfying regulatory requirements to model time and history, capturing complex changes and corrections, and integrating with dimensional modelling. In all cases, the underlying philosophy is that a data model is a description of a business, not of a database.

Three main themes are explored in a very practical way:

1. The foundations of data modelling – what a data model *really* is, and maximising its relevance
2. The human side of data modelling - improving communication skills and engaging the business
3. The complex side of data modelling - getting better at modelling difficult situations

Model-Driven Business Analysis Techniques – Proven Techniques for Processes, Applications, and Data 3 days

Simple, list-based techniques are fine as a starting point, but only with more rigorous techniques will a complete set of requirements emerge, and those requirements must then be synthesised into a cohesive view of the desired to-be state. This three-day workshop shows how to accomplish that with an integrated, model-driven framework comprising process workflow models, a unique form of use cases, service specifications, and business-friendly data models. This distinctive approach has succeeded on projects of all types because it is “do-able” by analysts, relevant to business subject matter experts, and useful to developers. It distills the material from Clariteq’s three, two-day workshops on process, data, and use cases & services.

*** Note: two-day in-person workshops are delivered virtually as three half-day sessions via Zoom.
Three-day in-person workshops are delivered virtually as five half-day sessions via Zoom.

Thank you!



Alec Sharp, West Vancouver, BC, Canada

If you have questions or comments...
don't be shy, get in touch!

- e: asharp@clariteq.com
- ig: [@alecsharp01](#)
- m: +1 604 418-3352